



**STANDARD  
SPECIFICATIONS  
AND DRAWINGS**

**VISIT**

**[www.diablowater.org](http://www.diablowater.org)**

**FOR MORE INFORMATION**

**UPDATED  
OCTOBER 2022**

# **1. Section Index**

**DIABLO WATER DISTRICT  
STANDARD SPECIFICATIONS AND DRAWINGS**

**SECTION INDEX**

**1. Section Index**

**2. Reference Indices**

- a. Materials Index
- b. Quick Reference Guide for Standard Drawings
- c. Quick Reference Guide for Cathodic Protection Drawings

**3. Abbreviations & Acronyms**

**4. General Requirements**

**5. Technical Specifications**

- a. Division 2 – Site Work
  - 02210 Trenching, Backfill and Compaction
  - 02230 Fill and Backfill Materials
  - 02231 Jack and Bore
  - 02512 Steel Pipe and Fabricated Specials
  - 02522 Groundwater Monitoring Well
  - 02610 Ductile Iron Pipe and Fittings
  - 02620 Polyvinyl Chloride (PVC) Pipe and Fittings
  - 02675 Water Pipeline Testing and Disinfection
  - 02830 Chain Link Fences and Gates
- b. Division 3 – Concrete
  - 03304 Concrete and Reinforcing Steel for Thrust Blocks
  - 03600 Cement Mortar and Grout
- c. Division 15 – Mechanical
  - 15100 Valves, Hydrants and Appurtenances
  - 15400 Services and Meter Installations
- d. Division 16 – Electrical
  - 16640 Corrosion Control Requirements

**6. Standard Drawings**

**7. Cathodic Protection System Drawings**

**DIABLO WATER DISTRICT  
STANDARD SPECIFICATIONS AND DRAWINGS**

**SECTION INDEX**

**8. Design Requirements**

- a. Subdivision Water System Design Requirements and Plan Review Checklist
- b. DWD General Water Notes
- c. Cathodic Protection Numbering Format for Subdivision Plans
- d. California Code of Regulations Title 22, Division 4, Chapter 16, Article 4 Materials and Installation of Water Mains and Appurtenances (includes Separation Requirements for Water Mains)
- e. System Pressures and Requirements for Individual Pressure Reducing Valves on Customer Services

**9. Construction Activities**

- a. Construction Sequence and Requirements
- b. Construction Submittal Checklist

## **2. Reference Indices**

**DIABLO WATER DISTRICT  
STANDARD SPECIFICATIONS AND DRAWINGS**

**MATERIALS INDEX**

<b>Item</b>	<b>Technical Specification</b>	<b>Standard Drawing</b>
Air release valve	15100	DWD 20 DWD 23 (alternate)
Backfill	02230	DWD 1
Ball valve	15100	--
Blowoff	15100	DWD 21 DWD 22
Bollard	--	DWD 24
Butterfly valve	15100	DWD 19
Cathodic protection	16640	DWD C1 through DWD C29
Controlled density fill	02230	--
Chain link fence	02830	DWD 14
Corporation stop	15400	DWD 8
Double check valve	15400	DWD 10
Double detector check valve	15400	DWD 13
Ductile iron pipe	02610	--
Fire hydrant	15100	DWD 15 DWD 16
Flanged coupling adapter	15100	--
Gate valve	15100	DWD 15 DWD 17 DWD 18
Gasket	02610, 15100	--
Insulating fittings	15100	--
Mechanical coupling	15100	--
Meter	15400	DWD 8 DWD 9

<b>Item</b>	<b>Technical Specification</b>	<b>Standard Drawing</b>
Meter box	15400	DWD 8 DWD 9
Monitoring Well	02522	DWD 25 DWD 26
Offset	02512	DWD 6 DWD 7
Pavement (temporary patching)	02210	DWD 1
PVC pipe	02620	--
Reduced pressure backflow preventer	15400	DWD 11 DWD 12
Service	15400	DWD 8
Spacer insulator	02231	DWD 5
Steel pipe	02512	DWD 6 DWD 7
Tapping tees and sleeves	15100	--
Thrust Blocks	03304	DWD 2 DWD 3 DWD 16
Trench	02210	DWD 1
Valve nut extension	15100	DWD 17
Valve stem	15100	DWD 18

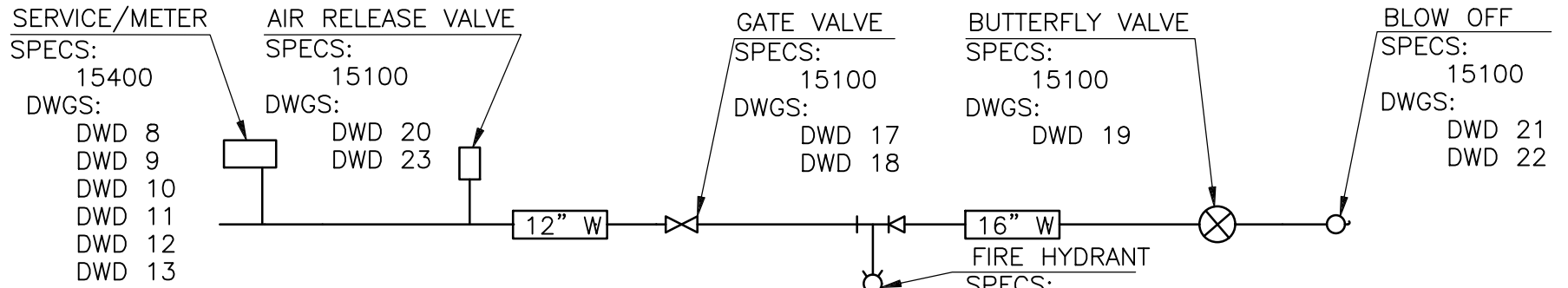

**PLAN**  
 NTS

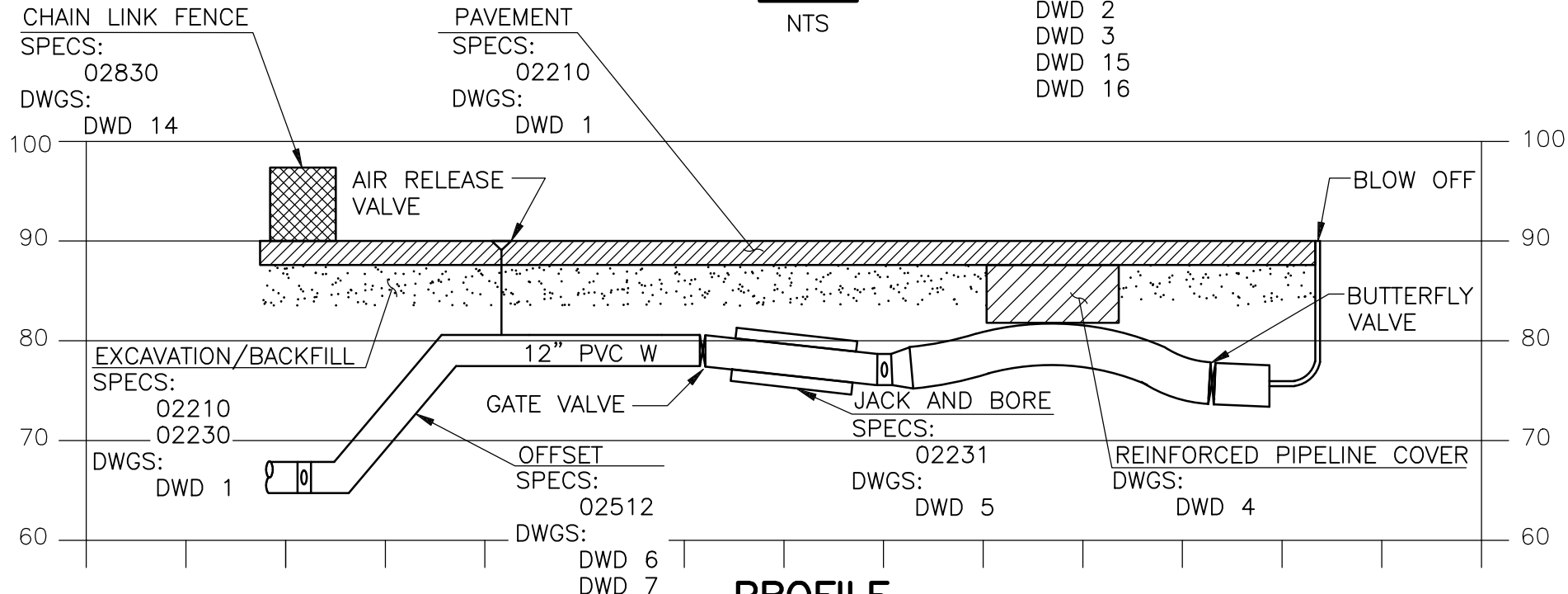

**PROFILE**  
 NTS

**DIABLO WATER DISTRICT**

STANDARD DRAWING  
**QUICK REFERENCE GUIDE**

DESIGNED WDB      DRAWN WKT      APPROVED WW      DATE OCTOBER, 2022      DWG. NO. **DWD 0**



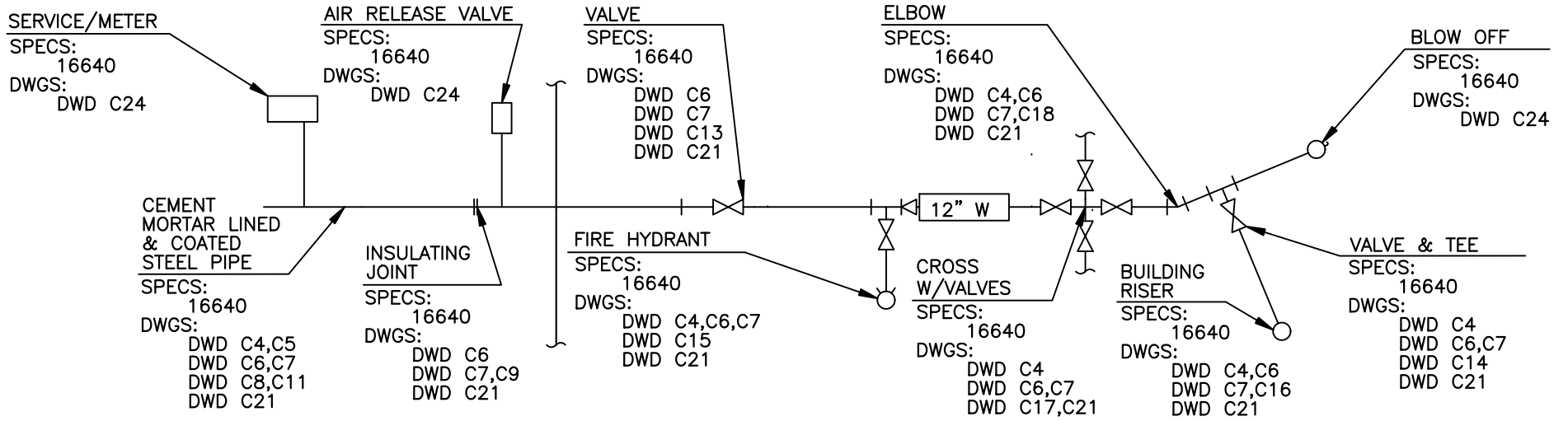

**PLAN**  
 NTS

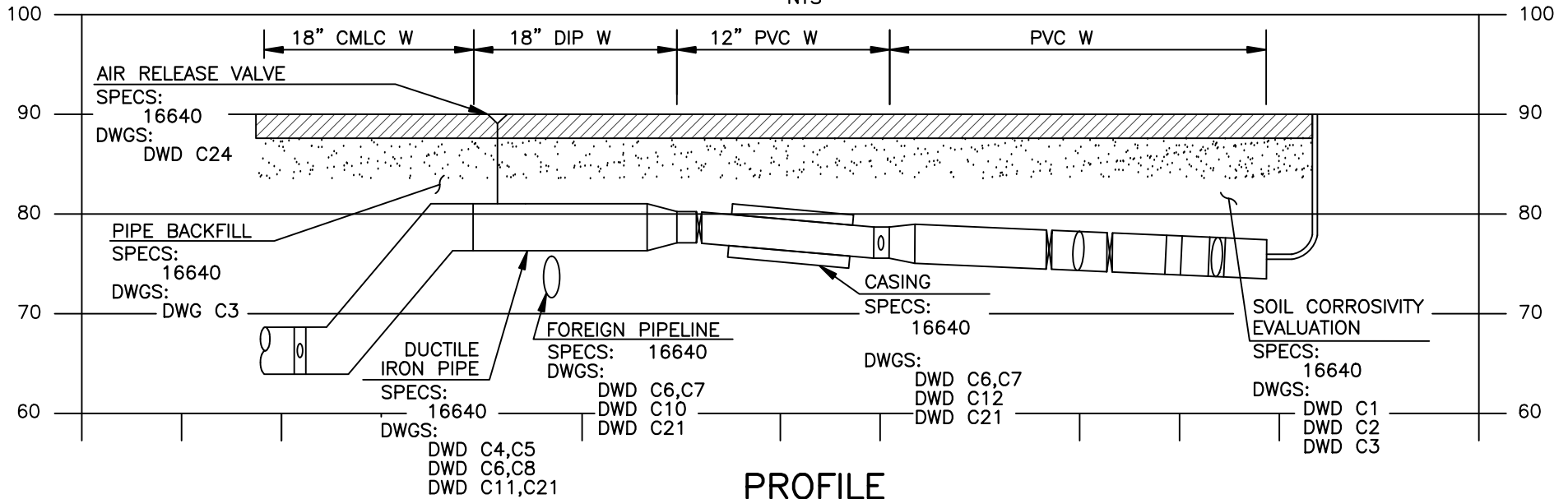

**PROFILE**  
 NTS

DIABLO WATER DISTRICT

STANDARD DRAWING

QUICK REFERENCE GUIDE – CATHODIC PROTECTION

DESIGNED MA DRAWN TH/JAW APPROVED WW DATE OCTOBER, 2022 DWG. NO. DWD CO

### **3. Abbreviations & Acronyms**

## ABBREVIATIONS & ACRONYMS

Whenever in these Standard Specifications and Drawings or in any of the other instruments which these specifications govern, the following abbreviations are used, they shall be defined as listed below:

#	Pound, number
AASHTO	American Association of State Highway Transportation Officials
AB	Aggregate Base
AC	Asphalt Concrete
AISC	American Institute of Steel Construction
AISI	American Iron and Steel Institute
ANSI	American National Standards Institute
API	American Petroleum Institute
APPROX	Approximately
APWA	American Public Works Association
ARV	Air Release Valve
ASA	American Standards Association
ASCE	American Society of Civil Engineers
ASME	American Society of Mechanical Engineers
ASSY	Assembly
ASTM	American Society for Testing Materials
AWS	American Welding Society
AWWA	American Water Works Association
BF	Blind flange
BFV	Butterfly valve
BO	Blowoff
BOW	Back of Walk
BR	Brass (Lead Free)

CFS	Cubic feet per second
CLR	Clear
CMLC	Cement mortar lined and coated
CMP	Corrugated metal pipe
CO	Cleanout
COMP	Compression
CONC	Concrete
CORP	Corporation
CP	Concrete pipe
CPLG	Coupling
CU	Cubic
DCVA	Double check valve assembly
DDC	Double detector check
DDW	Division of Drinking Water
DIA	Diameter
DIP	Ductile iron pipe
DISTRICT	Diablo Water District
DWD	Diablo Water District
DWG	Drawing
ELEV	Elevation
ELL	Elbow
ENGR	Engineer
EPDM	Ethylene propylene diene monomer
EST	Estimate
EW	Each way

---

Abbreviations & Acronyms

FBE	Flanged both ends
FCA	Flanged coupling adapter
FH	Fire hydrant
FLG	Flanged
FOE	Flanged one end
FPT	Female pipe thread
FT	Foot
GA	Gauge
GALV	Galvanized
GV	Gate valve
HE	Hub end
HYD	Hydrant
ID	Inside diameter, inside dimension
IP	Iron pipe
IPS	Iron pipe size
K	Copper pipe class
LFBR	Lead free brass
LG	Long
MAX	Maximum
MECH	Mechanical
MEE	Milled each end
MIN	Minimum
MIP	Male iron pipe (thread)
MJ	Mechanical joint

---

Abbreviations & Acronyms

NIC	Not in contract
NO	Number
NPT	National pipe thread
NRS	Non rising stem
NTS	Not to scale
OD	Outside diameter/outside dimension
OS&Y	Outside stem and yoke
OSHA	Occupational Safety & Health Act
PC	Portland cement
PCCP	Pretensioned concrete cylinder pipe
PE	Polyethylene pipe
PL	Property line
POE	Plain one end
PRV	Pressure reducing valve
PSF	Pounds per square foot
PSI	Pounds per square inch
PVC	Polyvinyl chloride
PVCP	Polyvinyl chloride pipe
RDWD	Redwood
RED	Reducing
REQ'D	Required
RP	Reduced pressure
RW, ROW	Right of way

---

Abbreviations & Acronyms

S	Sewer
SCHED	Schedule
SCLC	Steel cement mortar-lined and coated
SCRD	Screwed
SDS	Safety data sheet
SHT	Sheet
SQ	Square
ST	Street
STD	Standard
STL	Steel
STRUCT	Structural
SW	Solvent weld
TBE	Threaded both ends
TBO	Temporary blowoff
TJ	Tyton joint
TOE	Threaded one end
TYP	Typical
UL	Underwriters Laboratory, Inc.
USA	Underground Service Alert
UV	Ultraviolet or ultraviolet light
W	Water
W/	With
W/O	Without

---

Abbreviations & Acronyms

## **4. General Requirements**



## **GENERAL REQUIREMENTS**

### **PART 1      GENERAL**

#### **1.01    PURPOSE OF STANDARD SPECIFICATIONS AND DRAWINGS**

- A.     The purpose of these Standard Specifications and Drawings is to provide certain minimum requirements for the design, materials used, and methods of construction for Diablo Water District's water system facilities whether in public or private property.

#### **1.02    DEFINITIONS**

- A.     As used in these Standard Specifications and Drawings, the following terms have the meanings indicated:
  - 1.     "APPLICANT": Any individual, developer, partnership, public agency, or corporation requesting water service from the District.
  - 2.     "BOARD OF DIRECTORS": The Board of Directors of Diablo Water District.
  - 3.     "CONTRACTOR": The person or persons, firm or firms, co-partnership or corporation, who has or have entered into a contract with an Applicant or the District to perform work on water lines and appurtenances which are to be the property of or under the jurisdiction of the District.
  - 4.     "DISTRICT" or "OWNER": Diablo Water District, acting through its Board of Directors or authorized representatives.
  - 5.     "DRAWINGS" and "SPECIFICATIONS": Drawings and specifications for water service prepared by an Applicant or their representative.
  - 6.     "ENGINEER": As designated by the District, the engineer or authorized representative representing Diablo Water District.
  - 7.     "STANDARD DRAWINGS" and "STANDARD SPECIFICATIONS": Drawings and written matter included herein together with changes or additions which may be attached hereto.
  - 8.     "SUBCONTRACTOR": An individual, firm, or corporation having a direct contract with Contractor or any other subcontractor for the performance of a part of the Work at the site.

9. "WORK": Any and all obligations, duties, and responsibilities necessary to the successful completion of the project assigned to or undertaken by a contractor under contract to the District, including all labor, materials, equipment, and other incidentals, and the furnishing thereof.
- B. In addition, other Standard Specifications and Standard Methods are incorporated by reference and shall be considered a part of these Specifications as applicable. In general, the Standards in question shall be the latest amended standards adopted by the American Standards Association (ASA), by the American Water Works Association (AWWA), by the American Society of Civil Engineers (ASCE), by the American Society of Mechanical Engineers (ASME), by the American Welding Society (AWS), by the federal government, State of California, and County of Contra Costa. All referenced standards shall be the most recent version or edition.

### 1.03 PLAN REVIEW AND APPROVAL PROCESS

- A. GENERAL: All work necessary to the installation of water mains and appurtenances to provide water service shall be shown on drawings furnished by an Applicant. The drawings shall be prepared under the direction of, and signed by, a currently registered professional engineer in the State of California.
- B. DESIGN: Design of the water system improvements and preparation of the drawings shall follow the requirements contained in Section 8 - Design Requirements of this document. This work shall include cathodic protection improvements as required for the water facilities. Applicant shall also work with Joint Trench (JT) designer to avoid any other conflicts including, but not limited to, meter box locations and water/sewer service line separation.

All calculations requested by the District to verify the design of any portion of the water system shall be submitted. Calculations shall be based on methods generally accepted by the engineering profession and shall be neatly and legibly done in such form as to enable them to be readily checked. Literature and technical data concerning any of the materials and equipment proposed to be used shall be furnished upon request. If requested, soils report for the project area shall be submitted as part of the review process.

- C. APPROVAL OF DRAWINGS: The following must be submitted for review.
- Two full-sized sets of drawings showing the proposed work shall be submitted to the District for approval along with a PDF version of the drawings.
  - **Application for New Water Service, Extension of Water Main, or Other Facilities.** (available at [www.diablowater.org](http://www.diablowater.org))
  - Initial deposit requested by the District.

- The **Subdivision Water System Design Requirements and Plan Review Checklist** contained herein under Section 8 - Design Requirements shall be submitted with the drawings, with the applicable boxes checked by the Applicant. If the applicable design requirements are not followed, an explanation shall be provided with the submittal.
- The District shall review the drawings and provide comments in writing, as appropriate. The Applicant shall revise the drawings to address District comments, and re-submit the drawings as many times as needed to obtain District approval. Upon approval of the drawings the District shall so notify the Applicant in writing.
- Applicant shall deliver (4) four 24" X 36" and (2) two 11" X 17" sets of signed plans on **green paper** approved by all agencies to the District prior to commencement of construction or as requested by the District.

#### **1.04 PRIOR TO COMMENCEMENT OF CONSTRUCTION**

- A. **APPROVED PLANS:** Prior to commencement of construction, all drawings must be approved and fully signed by all approving agencies. Cathodic protection design and plans must be completed and approved, including submittal of soils test results for the cathodic protection design.
- B. **AGREEMENT:** Prior to commencement of construction, the Applicant shall enter into an agreement with the District. The agreement must be adopted by the District Board of Directors.

If within one year after the date of the approval of the drawings, the Applicant and the District have not executed an agreement for the construction of the work, the approval will then expire and be of no further effect. If thereafter the Applicant determines to execute an agreement with the District, four additional sets of prints shall be submitted to the District for approval. If the Applicant fails to commence and complete the work within the times stipulated in the Agreement, the District may rescind its approval of the drawings and require as a condition of the agreement specific modifications and revisions of the drawings.

- C. **BONDS AND INSURANCE:** Prior to commencement of construction, the Applicant shall deliver to the District all bonds and insurance certificates as required by the Agreement.
- D. **CONTRACTOR:** District shall approve the Contractor selected by the Applicant prior to commencement of construction.
- E. **PERMITS:** Applicant shall obtain all required permits for installation of the facilities at their own expense.

## 1.05 CONDUCT OF CONSTRUCTION WORK

- A. **GENERAL:** No work on facilities for, or related to, the District's water system shall be done until all drawings, including cathodic protection, have been approved by the District. Notification that the drawings are found in conformance with District standards shall not relieve the Applicant or Contractor of any responsibilities indicated in the Standard Specifications and Standard Drawings. Contractor shall at all times have at the work site this volume of the District's Standard Specifications and Drawings.
- B. **SUBMITTALS:** No work on facilities for, or related to, the District's water system shall be done until all necessary literature and technical data, for all materials, equipment and appurtenances proposed to be used, have been submitted to, and approved by, the District. Contractor shall have approved submittals on site at all times.
1. The Contractor shall not install any equipment or materials until the District has approved all submittals. If any equipment or materials are installed prior to approval of the submittals, it shall be at the Contractor's risk.
  2. In general, corrections or comments or lack thereof, made relative to submittals during review, shall not relieve the Contractor from compliance with the requirements of the drawings and specifications. Submittals are for review of general conformance with the design concepts of the project and general compliance with the contract documents. The Contractor is responsible for the final design conforming and correlating all quantities and dimensions, selecting fabrication processes and techniques of construction, coordinating the work of all trades, and performing the work in a safe and satisfactory manner.
- C. **MATERIALS:** All materials shall be checked on location by the Contractor. After materials have been received and checked by the Contractor, the Contractor shall notify the District that the proper materials have been delivered. No work shall commence until the District has inspected the materials.
- D. **SAFETY OFFICER:** The Contractor's Safety Officer shall be on location at all times during construction activities.
- E. **INSPECTION:** All materials furnished and all work performed shall be subject to inspection by the District. The materials and work shall be held strictly to the true intent of the Standard Specifications and Drawings in regard to quality of materials, workmanship, and diligent execution. Such inspection may include mill, plant, shop, or field inspection, as required. The District's inspector shall be permitted access to all parts of the work, including plants where materials or equipment are manufactured or fabricated, and he shall be furnished with such materials, information, and assistance as is required to make a complete and detailed inspection.

- F. **WORK DONE IN THE ABSENCE OF INSPECTION:** Work done in the absence of prescribed inspection may be required to be removed and replaced under the proper inspection, and the entire cost of removal and replacement, including the cost of all materials and labor which may be furnished by the District and used in the work thus removed, shall be borne by the Contractor, regardless of whether the work removed is found to be defective or not. Work covered up without the authority of the District, shall, upon order of the District, be uncovered to the extent required, and the Contractor shall similarly bear the entire cost of performing all the work and furnishing all the materials necessary for the removal of the covering and its subsequent replacement, as directed and approved by the District.
- G. **TESTING:** The District may make, or have made, such tests as he deems necessary to ensure that the work is being accomplished in accordance with the requirements of the District. In the event that any tests reveal noncompliance with the requirements of the contract, the Contractor shall bear the cost of such corrective measures deemed necessary by the District, as well as the cost of subsequent retesting.
- H. **DEFECTIVE MATERIAL OR WORK:** Materials or work not conforming to the requirements of these Standard Specifications, Drawings or submittals shall be considered as defective, and all such materials, whether in place or not, shall be rejected. No rejected material, the defects of which have been subsequently corrected, shall be used until approved in writing by the District.
- I. **DISCREPANCIES IN THE STANDARD SPECIFICATIONS AND DRAWINGS:** Any discrepancies, errors, or omissions, found in these Standard Specifications and Drawings shall be promptly reported to the District who may issue a correction or clarification in writing. The Contractor shall not take advantage of any such discrepancies, errors, or omissions, but shall comply with any corrective measures regarding the same prescribed by the District.

#### **1.06 AT COMPLETION OF CONSTRUCTION - PRIOR TO FINAL ACCEPTANCE**

- A. **TESTING:** Testing of all facilities shall be conducted according to all specifications and requirements contained herein. No facilities shall be accepted until the results of all final tests are satisfactory to the District.
- B. **PUNCH LIST:** All work and punch list items must be completed. The District shall assess a time frame for all punch list items to be completed. If not completed by the designated time, the District shall do so or have done by others after contacting the bonding company. The District will increase the deposit to cover the estimated punch list items. The deposit shall be refunded if the punch list is completed to the District's satisfaction within the stated timeframe.

- C. RECORD DRAWINGS: One full-size reproducible set of prints, revised to show record conditions shall be furnished to the District along with two sets of prints made from this record reproducible set. The reproducible set shall be photo quality on vellum or plain mylar; sepia or diazo mylar is not acceptable. It is suggested that a blue-line set of record drawings be provided for District review prior to submitting the mylars.

Provide the Global Positioning System (GPS) coordinates and elevations of all aboveground and underground valves, meters, fittings (including saddles and corporation stops) and blowoffs for all aboveground facilities as determined by the District in a shapefile data format as defined by ESRI. GPS coordinates of existing water facilities and all other utilities that are exposed during any construction activity shall also be provided. All GPS coordinates shall be to within an accuracy of ten (10) centimeters and shall include Latitude, Longitude and Elevation.

- D. CATHODIC PROTECTION (if required): Shall be tested and certified by registered engineer. Record drawings (mylars) shall be submitted. It is suggested that a blue-line set of record drawings be provided for District review prior to submitting the mylars. GPS coordinates shall be surveyed and recorded for all at-grade cathodic protection test stations.

## **1.07 FINAL ACCEPTANCE**

- A. ACCEPTANCE: Acceptance of an Applicant's project shall be made in writing by the District's General Manager after the work has been completed in accordance with District standards and approved drawings, and has been inspected and tested.

## **PART 2 CONSTRUCTION MATERIALS**

### **2.01 SCOPE OF WORK**

- A. All materials delivered to the worksite necessary to complete all work as shown on the drawings and/or as herein specified including, but not limited to, the following: pipe, fittings, valves, hydrants, and concrete.

### **2.02 MATERIAL SPECIFICATIONS**

- A. The Technical Specifications described herein contain the specific requirements for various materials.
- B. All materials shall be new; shall bear the manufacturer's stamp or marking; and shall conform to the most current revision of the cited specification(s).
- C. The Contractor shall, at any time when requested, submit to the District proper authenticated documents or other satisfactory proofs of compliance with the requirements of these specifications.

## 2.03 DELIVERY, STORAGE AND HANDLING

- A. During loading, transportation and unloading, care shall be taken to prevent damage to pipes, other materials, and their coating. Carefully load and unload each pipe and other materials under control at all times. Place skids or blocks under each pipe in the shop and securely wedge pipe during transportation to ensure no injury to pipe and lining. All pipe and pipe ends shall be covered during transport to prevent contaminants from entering or contacting the pipe. Pipe shall be kept covered at all times until ready to install.
- B. If the pipe or other materials are contaminated during delivery, storage or handling, Contractor shall clean the pipe or other materials to the satisfaction of the District. Failure to do so may result in DWD rejection of these materials.
- C. Any pipe damaged in shipment shall be removed from the site immediately as directed by the District's inspector and replaced.
- D. While stored, pipe shall be adequately supported from below at not more than 3 feet intervals to prevent deformation. Pipe shall not be stacked higher than 6 feet. Pipe and fittings shall be stored in a manner which will keep them at ambient outdoor temperatures. Temporary shading as required to meet this requirement shall be provided. Simple covering of the pipe and fittings which allows temperature buildup when exposed to direct sunlight will not be permitted.
- E. The pipe shall be handled by use of wide slings, padded cradles, or other devices, acceptable to the District, designed and constructed to prevent damage to the pipe coating. The use of chains, hooks, or other equipment which might injure the pipe coating will not be allowed. Stockpiled pipe shall be suitably supported and shall be secured to prevent accidental rolling. Pipe ends shall be protected from the weather. All other pipe handling equipment and methods shall be acceptable to the District.
- F. Stockpiled pipe shall be supported on sand or earth berms free of rock exceeding 3 inches in diameter. The pipe shall not be rolled and shall be secured to prevent accidental rolling.
- G. The Contractor shall be fully liable for the replacement of the full length of any pipe which is damaged or has been rejected by the District. Any attempts to repair a damaged section of pipe shall be performed under the direction of the District's inspector.

## **PART 3 GENERAL CONSTRUCTION REQUIREMENTS**

### **3.01 RIGHT-OF-WAY**

- A. Water mains, services, and meters shall be located in public right-of-way. In special cases, subject to the approval of the District, water mains may be located in a minimum twenty (20) foot wide utility easement dedicated to the District. Water mains shall be located five (5) feet from either edge of an easement. Additional utility easements may be required to accommodate water meters and other water facilities.

### **3.02 LOCATION OF EXISTING DISTRICT FACILITIES**

- A. Contractor agrees to take all responsibility for locating existing District facilities which may be within 10 feet of the Work. Contractor shall be responsible for ensuring that Underground Service Alert "*Call 811. Know what's below. Call before you Dig*" has been contacted before commencement of the Work and that the District's facilities have been adequately marked. Contractor shall dig by hand and by the use of probes to locate all existing District facilities prior to the use of mechanical equipment.

### **3.03 COMPLIANCE WITH STATE DIVISION OF DRINKING WATER**

- A. All requirements of the State Water Resources Control Board, Division of Drinking Water, including, but not limited to, water main separation distances, and pipe material specifications, shall be complied with.

### **3.04 INDIVIDUAL PRESSURE REDUCING VALVES ON CUSTOMER SERVICES**

- A. As described in the "Design Requirements" Section of this document, individual pressure reducing valves shall be required on all customer services at locations designated by the District with ground elevations less than 15 feet above mean sea level.

### **3.05 LINE AND GRADE**

- A. The Contractor shall lay out the work in advance of beginning construction. The Contractor is responsible for constructing the work to the lines and grades shown in the Contract Documents. The trench shall be excavated to a flat bottom, cut true and even to the established grade. Contractor shall use a slope laser to ensure grades are true and correct. Construction staking in new developments will be provided by the Applicant. Staking shall be to the flow line of the pipe.



### 3.06 INSTALLATION OF WATER MAINS

- A. All pipe, fittings, and specials, shall be carefully handled and protected against damage to lining and coating, impact shocks and free fall. Pipe shall not be placed directly on rough ground but shall be supported in a manner which will protect the pipe against injury whenever stored at the site of the work or elsewhere. No pipe shall be installed when the lining or coating show cracks as defined in AWWA C205. Such damaged lining and coating shall be repaired, or a new undamaged pipe or fitting or special shall be furnished and installed. In the event a new and undamaged item is furnished, the damaged item shall be marked by the District and removed from the site.
- B. Before placement of pipe in the trench, each pipe or fitting or special shall be thoroughly cleaned of any foreign substance which may have collected thereon and shall be kept clean at all times thereafter. For this purpose, the openings of all pipes, fittings, and specials in the trench shall be closed during any interruption in the installation of the pipe. All pipe, fittings, specials, valves, etc., shall be carefully lowered into the trench by suitable tools or equipment, in such manner as to prevent damage to the pipe, lining, coating, fitting, special, or other appurtenances. Damage to the lining or coating shall be repaired to the satisfaction of the Engineer or the District's inspector before the pipe or fitting or special is installed.
- C. The Contractor shall inspect each pipe and fitting to ensure there are no damaged portions of the pipe. The Contractor shall remove or smooth out any burrs, gouges, weld splatter or other small defects prior to laying pipe.
- D. The District may examine each bell and spigot end to determine whether any preformed joint has been damaged prior to installation. Any pipe having defective joint surfaces shall be rejected, marked as such, and immediately removed from the job site.
- E. Pipe shall be laid to the lines and grades shown on the Drawings with bedding and backfill as shown on the Drawings. Blocking under the pipe will not be permitted. All pipe lettering or identification shall be facing up. The deflection at joints shall not exceed that recommended by the manufacturer. If any defective pipe is discovered after it has been installed, it shall be removed and replaced with a sound pipe in a satisfactory manner by the Contractor, at their own expense.
- F. The materials used for the bedding, and the amount thereof, and the manner of deposition shall be subject to the approval of the District, but the Contractor shall be held responsible for any displacement or instability of pipelines or any damage to coatings caused by improper installation of bedding materials.

- G. Installation of pipes in prepared trenches shall start at the lowest elevation, with the spigot ends pointing in the direction of flow. Pipe shall be protected from lateral displacement by placing the specified pipe embedment material. Pipe shall be laid with the bell ends facing the direction of laying except when reverse laying is specifically authorized by the District.
- H. The pipe shall be laid true to line, with no visible change in alignment at any joint, unless curved alignment is shown on the drawings. No single piece of pipe shall be laid unless it is generally straight. The centerline of the pipe shall not deviate from a straight line drawn between the centers of the openings at the ends of the pipe by more than 1/16 inch per foot of length. If a piece of pipe fails to meet this requirement check for straightness, it shall be rejected and removed from the site.
- I. Except for short runs which may be permitted by the District, pipes shall be laid uphill. Pipe which is laid on a downhill grade shall be blocked and held in place until sufficient support is furnished by the following pipe to prevent movement. Pipes shall be laid uphill on grades exceeding 10 percent.
- J. Good alignment shall be preserved during installation. Fittings, in addition to those shown on the plans, shall be provided, if required, in crossing utilities which may be encountered upon opening the trench.
- K. The locations of metal fittings requiring cathodic protection test stations shall be consolidated whenever possible. The District may require that fusible PVC water mains be installed in some locations, especially sections of roadway with horizontal or vertical curves, to achieve this.
- L. Pipe joints shall be made only with the couplings and rubber rings furnished with the pipe or with mechanical couplings, and aligned and constructed in the trench in accordance with the manufacturer's instructions.
- M. Whenever pipe laying is discontinued for short periods, or when work is stopped at the end of the day, the open ends of all pipes shall be closed with watertight plugs, bulkheads or other approved means. The plug or bulkhead shall not be removed, unless or until the trench is dry.
- N. Under no circumstances shall pipe be laid in water, and no pipe shall be laid under unsuitable weather or trench conditions. All necessary precautions shall be taken to prevent uplift or flotation of the pipe prior to the completion of the backfilling operation. The Contractor shall assume full responsibility for any damage due to this cause and shall, at its own expense, restore and replace the pipe to its specified condition and grade if it is displaced due to floating.

- O. As pipe laying progresses, the Contractor shall keep the pipe interior free of all debris and clean until testing. The Contractor shall completely clean the interior of the pipe of all sand, dirt, mortar splatter and any other debris or foreign matter following completion of pipe laying, pointing of joints and any necessary interior repairs prior to testing and disinfecting the completed pipeline. The lowest segment shall be flushed last to assure debris removal. If, after this cleaning, obstructions remain, they shall be removed.
- P. If any defective item is discovered after it has been installed, it shall be removed and replaced with an exact replacement item in a satisfactory manner by the Contractor, at the Contractor's own expense.
- Q. Plastic warning tape shall be installed over all water lines as shown on Standard Drawing DWD-1. Warning tape shall be blue, minimum 6" inches wide, and printed continuously with the words: "CAUTION BURIED WATER LINE BELOW". Pipe shall be laid with all pipe lettering or identification markings shall be facing up.

### **3.07 WARRANTY**

- A. The Contractor/Developer shall obtain a labor and materials bond that guarantees that the pipe furnished is suitable for the purpose intended and free from defects of material and workmanship for a period of three years after initial startup. In the event the pipeline or its appurtenances fails to perform as specified, the Contractor/Developer shall promptly replace all defective materials at no additional cost to the District.

### **3.08 INTERRUPTION OF SERVICE**

- A. If the District agrees that a portion of the distribution system needs to be shutdown with interruption of service to hydrants or customers, then a written request, including the shutdown duration and a work plan, shall be submitted to the District for approval. Shutdowns will be limited to the period between 9:00 a.m. and 4:00 p.m., Tuesday through Thursday and preferably should not include mealtime hours. If a shutdown is approved, the District shall be notified 48 hours prior to commencing the work.
- B. Tie-ins cannot occur at night without proper notification. District may choose to make tie-ins after hours so it does not interfere with businesses, etc.
- C. Preparations shall be made and work planned so that the shutdown time will be as short as possible. Requests for shutdowns beyond the aforementioned times and days may be reviewed for approval by the District on a case-by-case basis. Should the approved shutdown time be exceeded, a penalty of \$100 for every hour over that approved shutdown may be assessed against the party requesting the shutdown.

- D. After having secured the approval of the District, the party requesting the shutdown will notify the local fire protection district and all customers to be affected at least 2 weeks in advance of, with a follow-up 48 hours before, any interruption to service or as directed by the District's inspector. The fire protection district shall be immediately notified when service to the affected area is restored.

### **3.09 VALVE OPERATION**

- A. Only District representatives and individuals specifically designated by the District shall open or close any valve in the existing water system.

### **3.10 CONNECTING TO EXISTING MAINS**

- A. **EXPOSING EXISTING FACILITIES:** When connections are to be made to any existing pipe or other appurtenances, the actual size, elevation, or position or location of which cannot be determined without excavation, the Contractor shall carefully excavate and expose the existing facility. The facilities shall be inspected prior to starting any water main installations.
- B. **WET TAPPING:** Connections to the water distribution system shall be made by use of the wet tapping method unless 1) the pipe to be connected is at least 4 inches larger than the main, or 2) the District agrees that wet tapping is impossible or impracticable. The Contractor shall give the District 48 hours notice in writing prior to commencing on any wet tap into the water system. The Contractor shall not proceed until it receives the District's approval which is subject to inspector availability. No taps shall be scheduled on Fridays unless prior approval is received from the District.

The work crew performing the wet tap must be acceptable to the District and be capable, experienced, and responsible. The Contractor shall immediately replace any wet tap work crew which the District judges to be irresponsible or unskillful. A representative of the District shall be present before and during any wet taps.

### **3.11 ABANDONED FACILITIES**

- A. Buried pipelines and valving to be abandoned shall be abandoned in place unless otherwise indicated "TO BE REMOVED". The ends of such pipelines shall be capped or plugged and all valving shall be closed, if possible. Details with the location, size, and material of the abandoned facility shall be accurately noted on the project record drawings (as-builts).

### **3.12 CONSTRUCTION WATER SUPPLY**

- A. All water is to be metered and paid for by the Contractor. Meters for this purpose are available at the District office following application for same, and a deposit is required. If a meter is not available, the Contractor may submit on a meter which must include a current certificate of calibration.

Meter must be for potable use only. Contractors using their water meter for the temporary jumper must have yearly calibration tests performed and shall submit the report to the District.

- B. The deposit, service charge, and consumption charge will be those stated in the rules and regulations of the District as they are in effect from time to time. The District shall be entitled to assess such charges against the Contractor and deduct the cost thereof from any money due or that may become due the Contractor under this or any other contract.

### **3.13 FILLING WATER TRUCKS AND OTHER WATER TRANSPORT EQUIPMENT FROM FIRE HYDRANTS**

- A. An air gap or an approved reduced pressure principle backflow preventer shall be utilized to isolate the water system from the water storage compartment being filled. See the figure on the following page.

### **3.14 SAFETY**

- A. The Contractor's Safety Officer shall be on location at all times.
- B. The Contractor shall at all times conduct their work in accordance with Construction Safety Orders of the Division of Industrial Safety, State of California, to ensure the least possible obstruction to traffic and inconvenience to the general public, and adequate protection of persons and property in the vicinity of the work. No street shall be closed to the public without first obtaining permission of the District and the other proper governmental authorities.
- C. Toe boards shall be provided to retain excavated materials if required by the District or the public entity having jurisdiction over the street or highway. Fire hydrants on or adjacent to the work shall be kept accessible to fire fighting equipment at all times. Temporary provisions shall be made by the Contractor to ensure the use of sidewalks and the proper functioning of all gutters, sewer inlets, and other drainage facilities.

### **3.15 MAINTENANCE OF TRAFFIC**

- A. Contractor shall conduct their work to interfere as little as possible with public travel, whether vehicular or pedestrian. Whenever it is necessary to cross, obstruct, or close roads, driveways, and walks, whether public or private, Contractor shall provide and maintain suitable and safe bridges, detours, or other temporary expedients for the accommodation of public and private travel, and shall give reasonable notice to owners of private drives before interfering with them. Such maintenance of traffic will not be required when Contractor has obtained permission from the owner and tenant of private property, or from the authority having jurisdiction over public property involved, to obstruct traffic at the designated point. Traffic control shall be provided by applicant or contractor as needed for District personnel to operate valves or other activities. It is the Contractor's

responsibility to contact local governing agencies regarding submittal and approval of traffic detour plans prior to the commencement of work.

### **3.16 BARRICADES AND LIGHTS**

- A. All streets, roads, highways, and other public thoroughfares which are closed to traffic shall be protected by effective barricades on which shall be placed acceptable warning signs. Barricades shall be located at the nearest intersecting public highway or street on each side of the blocked section.
- B. All open trenches and other excavations shall have suitable barricades, signs, and lights to provide adequate protection to the public. Obstructions such as material piles and equipment shall be provided with similar warning signs and lights.
- C. All barricades and obstructions shall be illuminated with warning lights from sunset to sunrise. Material storage and conduct of the Work on or alongside public streets and highways shall cause the minimum obstruction and inconvenience to the traveling public.
- D. All barricades, signs, lights, and other protective devices shall be installed and maintained in conformity with applicable statutory requirements.

### **3.17 SANITARY FACILITIES**

- A. Contractor shall furnish temporary sanitary facilities at the site for the needs of all construction workers and others performing work or furnishing services on the project. Sanitary facilities shall be of reasonable capacity, properly maintained throughout the construction period, and obscured from public view to the greatest practical extent. Contractor shall enforce the use of such sanitary facilities by all personnel at the site.

### **3.18 CARE OF EXISTING STRUCTURES AND UTILITIES**

- A. GENERAL: Existing power and telephone lines, trees, fences, water pipes, gas lines, sewer or other conduits, embankments, and sundry structures, in the vicinity of the work shall be supported and protected from injury by the Contractor during the construction and until the completion of the work. The Contractor shall be liable for all damages done to such structures.
- B. EXISTING UTILITIES: Contractor shall be responsible for ensuring that Underground Service Alert-“*Call 811. Know what’s below. Call before you Dig*” has been contacted before commencement of the Work that all existing utilities in the vicinity of the work have been marked.

- C. **RELOCATION OF EXISTING UTILITIES:** The Contractor shall make all arrangements for, and pay all costs connected with, any necessary relocation and/or reconstruction of existing surface and underground utility facilities (including without limitation, poles, guys, conduits, pipes, and mains) affecting the project or the work to be performed.
- D. **UNIDENTIFIED EXISTING UTILITIES:** If, in the performance of the work, an existing utility is encountered which is not shown on the drawings and is not apparent or inferable from visual inspection of the site, the District shall be notified immediately. The District will determine whether the drawings or specifications shall be modified, or whether the existing utility shall be relocated or whether the Contractor shall work around the existing utility. GPS coordinates shall be collected from other utilities exposed during construction of new utilities.
- E. **PROTECTION OF TREES, SHRUBS AND LAWNS:** The Contractor shall take every necessary precaution to protect trees, shrubs, lawns, and other vegetation in all areas on or adjacent to the worksite(s). No trees or shrubs shall be removed or trimmed unless the drawings specifically state otherwise.

### **3.19 MAINTAINING DRAINAGE**

- A. The Contractor shall provide and maintain temporary drainage for all excavations, drains, sewers, ditches, trenches, and structures. The Contractor shall keep the excavations dry throughout the construction operations. Whenever necessary in order to provide proper drainage, the Contractor shall, at their own expense, install underdrains, and furnish and operate all necessary pumping equipment, drainage sumps, wellpoint systems, and other drainage facilities. The laying of pipe or placing of concrete will not be allowed under circumstances where water is standing in the excavation.
- B. The Contractor shall dispose of the water from the work in a suitable manner without damage to adjacent property and in such a manner as not to be a menace to the public health. No water shall be drained into work built or under construction without prior consent of the Engineer.

### **3.20 RAILROAD CROSSINGS**

- A. Wherever the work to be done under these specifications includes encroachment upon railroad rights-of-way, easement, or permit, the Applicant and Contractor are responsible for entering into an agreement with the railroad company. The Contractor shall comply with all requirements imposed by the railroad company in connection with performance of the work and shall give such notice as is required before beginning work. The Contractor shall be responsible for the payment of any necessary watchmen, flagmen, or inspectors or any other protection required on the work by the railroad.

### **3.21 DUST CONTROL**

- A. The Contractor shall at all times keep the streets sufficiently watered and swept of all loose material produced by their operations in order that traffic and construction does not raise an objectionable amount of dust. When directed by the District, the Contractor shall apply a suitable dust palliative to control dust.

### **3.22 NOISE CONTROL**

- A. The Contractor shall take reasonable measures to avoid unnecessary noise. Such measures shall be appropriate for the normal ambient sound levels in the area during working hours. All construction machinery and vehicles shall be equipped with practical sound muffling devices, and operated in a manner to cause the least noise consistent with efficient performance of the work.

### **3.23 POLLUTION CONTROL**

- A. The Contractor shall prevent the pollution of drains and watercourses by sanitary wastes, sediment, debris, and other substances resulting from construction activities. No sanitary wastes will be permitted to enter any drain or watercourse other than sanitary sewers. No sediment, debris, or other substance will be permitted to enter sanitary sewers and reasonable measures will be taken to prevent such materials from entering any drain or watercourse. Applicant and Contractor shall be responsible for obtaining any required permits for discharge to the sanitary sewer, and/or for the General Stormwater Permit for Construction Activities, including submittal of the Notice of Intent and preparation of the Stormwater Pollution Prevention Plan (SWPPP).

### **3.24 COUNTY, CITY OR STATE ROADS**

- A. Whenever the work to be done under these specifications includes encroachment upon county, city, or state road rights-of-way, the Contractor shall comply with all requirements imposed by the governing agency in addition to those set forth in these specifications, in connection with performance of the work and shall give such notice as is required before beginning work.
- B. The Contractor is responsible for securing the necessary rights-of-way, easement, or permit whenever work is to be done under these specifications including encroachment upon county, city, or state road rights-of-way and bear all fees associated herewith.

### **3.25 SECURITY**

- A. The Contractor shall be responsible for protection of the site, and all work, materials, equipment, and existing facilities thereon, against vandals and other unauthorized persons.



### 3.26 PASSIVE PURGE SYSTEM

- A. Flow-through (passive purge) fire protection systems will be implemented on all new residential buildings unless prior approval is given by the District for the development to use backflow prevention devices, or similar devices, to protect the potable water main when residential fire protection systems are installed.
- B. Flow-through (passive purge) fire protection systems will be implemented for residential buildings in accordance with National Fire Protection Association (NFPA) 13D standards for single family dwellings and duplexes. See Attachment A, Figure 1 for a typical passive purge connection detail. For multi-storied residences, each level must be passively purged.
- C. The use of residential flow-through (passive purge) fire protection systems can eliminate the need for a backflow prevention assembly to be installed behind the service meter. However, a backflow prevention device may be required for the residence(s) at the discretion of the District, for example, when the property receiving a water service lies adjacent to a water body.
- D. Flow-through fire protection systems shall not be implemented for commercial, industrial, and large multi-family residences. Fire protection systems for these areas shall be in compliance with NFPA 13 and NFPA 13R standards.
- E. Flow-through (passive purge) fire protection systems shall be designed per NFPA 13D standards to be passively purged through connections to regularly used potable water fixtures. The type of fixtures used to achieve flow-through fire protection systems shall be constructed using potable water piping and materials in accordance with NFPA 13D and AWWA requirements. Fire sprinkler piping systems in flow-through fire protection systems are typically connected to a toilet to prevent water stagnation. See Attachment A, Figure 2 for a typical toilet connection detail.
- F. Fire department connections must not be attached to the passive purge system.

# ATTACHMENT A

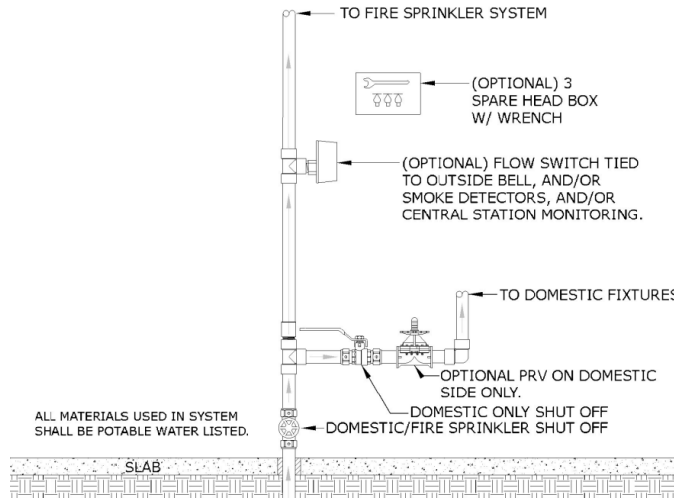

Figure 1: Typical Passive Purge System Riser

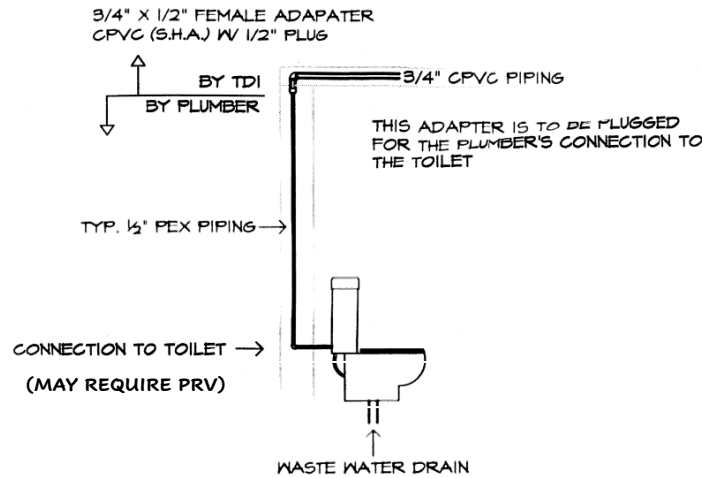

Figure 2: Typical Toilet Connection Detail

END OF SECTION

## **5. Technical Specifications**

**DIABLO WATER DISTRICT  
STANDARD SPECIFICATIONS AND DRAWINGS**

**TECHNICAL SPECIFICATIONS**

Division 2    Sitework

02210	Trenching, Backfill and Compaction
02230	Fill and Backfill Materials
02231	Jack and Bore
02512	Steel Pipe and Fabricated Specials
02522	Groundwater Monitoring Well
02610	Ductile Iron Pipe and Fittings
02620	Polyvinyl Chloride (PVC) Pipe and Fittings
02675	Water Pipeline Testing and Disinfection
02830	Chain Link Fences and Gates

Division 3    Concrete

03304	Concrete and Reinforcing Steel for Thrust Blocks
03600	Cement Mortar and Grout

Division 15   Mechanical

15100	Valves, Hydrants and Appurtenances
15400	Services and Meter Installations

Division 16   Electrical

16640	Corrosion Control Requirements
-------	--------------------------------

## SECTION 02210

### TRENCHING, BACKFILL AND COMPACTION

#### PART 1 GENERAL

##### 1.01 SUMMARY

- A. Furnish all labor, materials, equipment and incidentals required and perform all trenching for pipelines and appurtenances, including drainage, filling, backfilling, disposal of surplus material and restoration of trench surfaces and easements.
- B. Excavation shall extend to the width and depth shown on the Drawings or as specified herein and shall provide suitable room for installing pipe, structures and appurtenances.
- C. Furnish and place all sheeting, bracing and supports and remove from the excavation all materials which the District may deem unsuitable for backfilling. The bottom of the excavation shall be firm, dry and acceptable to the District. No more than 500 feet of open trench will be allowed at any time.
- D. The length of open trench shall be related closely to the rate of pipe laying. No more than 500 feet of open trench will be allowed at any time. All pipe shall be backfilled by the end of the day.
- E. All excavation, trenching and related sheeting, bracing, etc., shall comply with the requirements of OSHA excavation safety standards (29 CFR Part 1926.650 Subpart P) and State requirements. Where conflict between OSHA and State regulations exists, the more stringent requirements shall apply.
- F. Wherever the requirement for "90 percent" or "95 percent" compaction is specified it shall mean at least 90 percent or 95 percent of maximum density as determined by ASTM D1557 (Modified Proctor), Methods A/B/C.
- G. Prior to the start of work submit the proposed method of backfilling and compaction to the District for review and approval.

##### 1.02 REFERENCE STANDARDS

- A. Referenced standards shall be the most recent version or edition.
- B. American Society for Testing and Materials
  - 1. ASTM D1557 – Standard Test Methods for Laboratory Compaction Characteristics of Soil Using Modified Effort (56,000 ft-lbf/ft<sup>3</sup> (2,700 kN-m/m<sup>3</sup>))

- C. American Association of State Highway and Transportation Officials
  - 1. Test No. T180
- D. California Department of Transportation
  - 1. Standard Specifications Section 26 – Aggregate Bases

**PART 2 PRODUCTS (NOT USED)**

**PART 3 EXECUTION**

**3.01 TRENCH EXCAVATION**

- A. Trench excavation shall include material of every description and of whatever substance encountered, except rock and boulders.
- B. Pavement to be removed shall be removed in the manner prescribed by the local city, county, or state governing agency. In addition to the pavement removed for trenches, an additional 12 inches on each side of the trench shall be removed. The pavement shall be saw cut to neat lines prior to trenching, parallel to the trench at the width required. Any pavement damaged outside these lines shall be restored by the Contractor at their own expense.
- C. Strip and stockpile topsoil from grassed areas crossed by trenches. At the Contractor's option, topsoil may be disposed of and replaced, when required, with approved topsoil of equal quality.
- D. While excavating and backfilling is in progress, traffic shall be maintained, and all utilities and other property protected as provided in the General Conditions.
- E. Width of Trenches: For pipelines 24 inches and smaller, the width of unsheathed trenches shall not be greater than 24 inches plus the exterior diameter of the pipe barrel. For pipelines larger than 24 inches, unsheathed trenches shall not be greater than 48 inches plus the exterior diameter of the pipe barrel. Where sheathing is required, the width of trench shall be increased only sufficiently to accommodate the sheathing and timbers plus necessary tools and installation equipment. Whenever the maximum allowable trench width is exceeded for any reason, the Contractor shall, at their expense, embed or cradle the pipe in concrete in a manner satisfactory to the District. In no case shall the free working space on each side of the pipe be less than 12 inches.
- F. Maximum Length of Open Trench: Unless otherwise specified or directed by the District, the maximum length of open trench shall be 500 feet, or the distance necessary to accommodate the amount of pipe installed in a single day, whichever is greater. The distance is the collective length of any location, including open excavation, pipe laying and appurtenant construction and backfill which has not been temporarily resurfaced. Failure by the Contractor to comply with the limitations specified herein may result in an order to halt progress of the work until compliance has been achieved.

- G. Trenches shall be excavated to the depth indicated on the Drawings and in specified widths sufficient for laying the pipe, bracing and for pumping and drainage facilities. Contractor shall use a slope laser for all grading and to set pipe. The bottom of the excavations shall be firm and dry and acceptable to the District. When trench excavations exceed the regulated depth, the Contractor shall apply for a "Permit to perform excavation or trench work" from the nearest office of the Division of Occupational Safety and Health.
- H. Where the bottom of the trench is found to be unstable or to include material which, in the opinion of the District, is unsuitable for proper bedding of pipelines, the Contractor shall over excavate and remove such material to the width and depth ordered by the District. Before the pipe is laid, a new subgrade shall be prepared by backfilling and compacting with an approved material in layers of not more than 6 inches in uncompacted depth. The layers shall be thoroughly compacted as required to provide adequate bearing and support.
- I. Where the bottom of the trench is found to consist of material which is unstable to a degree that, in the opinion of the District, it cannot be removed and replaced with an approved material to properly support the pipeline, the Contractor shall construct a foundation for the pipe in accordance with plans prepared by the District.
- J. Excavation and dewatering shall be accomplished by specified methods which preserve the undisturbed state of subgrade soils. The trench may be excavated by machinery to, or just below the designated subgrade, provided that material remaining in the bottom of the trench is no more than slightly disturbed. Subgrade soils which become soft, loose, "quick", or otherwise unsatisfactory as a result of inadequate excavation, dewatering or other construction methods shall be removed and replaced by aggregate base or crushed rock as required by the District at the Contractor's expense.
- K. Clay and organic silt soils are particularly susceptible to disturbance due to construction operations. When excavation is to end in such soils, use a smooth-edge bucket to excavate the last 1 foot of depth.
- L. Trench excavation shall include the removal of all soil, rock, pavement, tree stumps (or other vegetation or vegetable matter), waste or debris, abandoned pipelines or other structures, ground water and materials of any nature which interfere with the construction work.
- M. Where pipe is to be laid directly on the trench bottom, final excavation at the bottom of the trench shall be performed manually, providing a flat bottom true to grade upon undisturbed material. Bell holes shall be made as required.
- N. Additional manual excavation may be required if a suitable foundation cannot be achieved with mechanical equipment. Bell holes shall be made as required.

- O. At the end of each day all open trenches within paved streets shall be backfilled or steel plated with decking and adequate trench bracing to facilitate the next day's work unless otherwise required by governmental permit. The use of steel plating and decking above the open trench must be approved by the District for each location, and shall be limited to exposure of the pipe end of the last length of pipe installed. No other open trenches shall be allowed at the end of each workday, except by written permission of the District. Alternative protective measures may only be utilized following receipt of written permission by the District.

### **3.02 OVEREXCAVATION**

- A. Wherever, due to over excavation or inaccurate trimming, the Contractor shall refill and compact the trench with backfill material, specified herein, and consolidate and reshape the trench bottom to the required cross-section and grade.

### **3.03 DISPOSAL OF MATERIALS**

- A. Excavated materials shall be stored so as to offer minimum obstruction to traffic and the normal use of adjacent properties. Excavated material shall be stacked without excessive surcharge to the trench bank and without obstructing free access to hydrants, valves, meters, or private drives. Inconvenience to traffic and abutters shall be avoided as much as possible. Excavated material shall be segregated for use in backfilling as specified below.
- B. The Contractor shall make the necessary arrangements for, and shall remove and dispose of all excess excavated material. The Contractor shall not dump material on any private property without the permission of the property owner thereof.
- C. It is the intent of these Specifications that all surplus material from the combined phases of the project not required for backfill or fill shall be disposed of by the Contractor outside the limits of the public rights-of-way and/or easements.
- D. No excavated material shall be deposited on private property unless written permission from the property owner thereof is secured by the Contractor.
- E. Should conditions make it impracticable or unsafe to stack material adjacent to the trench, the material shall be hauled and stored offsite.

### **3.04 SHEETING AND BRACING**

- A. Where necessary, trenches and other excavations shall be properly sheathed and braced to furnish acceptable working conditions. Bracing shall comply in all respects to rules, orders and regulations prescribed by the California Administrative code, Title 8, Chapter 4.



- B. Furnish, put in place, and maintain sheeting and bracing required by Federal, State or local safety requirements to support the sides of the excavation and prevent loss of ground which could endanger personnel, or structures or delay the work. If in the District's opinion proper supports have not been provided, he/she may order additional supports placed at the expense of the Contractor. Compliance with such order shall not relieve the Contractor from their responsibility for the sufficiency of such supports. Care shall be taken to prevent voids outside of the sheeting, but if voids are formed, they shall be immediately filled and compacted.
- C. Shoring of any nature will be in accordance with OSHA standards or more stringent if needed. The Contractor shall ensure all safety requirements are met.
- D. The bracing shall be arranged not to place stress on portions of the completed work until the construction thereof has proceeded far enough to provide ample strength. Any damage to structures occurring through settlement, water or earth pressures, slides, caves, or other causes, due to failure or lack of sheeting or bracing, or improper bracing, or through negligence or fault of the Contractor in any manner, shall be repaired by the Contractor. Sheet piling and other timbering shall be withdrawn in such a manner as to prevent caving of the walls of excavations or damage to piping or other structures.
- E. When moveable trench bracing such as trench boxes, moveable sheeting, shoring or plates are used to support the sides of the trench, care shall be taken in placing and moving the boxes or supporting bracing to prevent movement of the pipe, or disturbance of the pipe bedding and the screened gravel or crushed rock backfill.
  - 1. When installing flexible pipe, trench boxes, moveable sheeting, shoring or plates shall not be allowed to extend below the springline of the pipe. As trench boxes, moveable sheeting, shoring or plates are moved, screened gravel or crushed rock shall be placed to fill any voids created and the screened gravel and backfill shall be recompacted to provide uniform side support for the pipe.
- F. Steel sheeting may be used in lieu of wood sheeting for the entire job wherever the use of sheeting is necessary.
- G. All sheeting and bracing shall be carefully removed in such manner as not to endanger the construction of other structures, utilities, or property, whether public or private. All voids left after withdrawal of sheeting shall be immediately refilled with sand by compacting with tools especially adapted to that purpose, by watering or as directed by the District.
- H. When trench excavations exceed the regulated depth, the Contractor shall apply for a "permit to perform excavation or trench work" from the nearest office of the Division of Occupational Safety and Health.

### 3.05 TRENCH BACKFILL REQUIREMENTS – GENERAL

- A. Under normal conditions, minimum cover for water mains in major streets shall be 4 feet from the top of the pipe to the finished ground surface. Water mains within subdivisions shall have a minimum of 3 feet of cover. PVC and ductile iron may be laid to a maximum cover of 6 feet to clear obstructions. Where greater depths are required to clear obstructions, steel offsets as shown on Standard Drawings DWD 6 and DWD 7 shall be used. When minimum cover requirements cannot be met, a concrete reinforced pipeline cover section per DWD 4 shall be used, with the District's permission.
- B. Before backfilling, the trench shall be cleared of all trash, timber and debris such as wood blocks, grade stacks, paper, rope, rags, loose rock over 3 inches, and broken pavement. Care shall be taken to ensure that backfill material is free of debris.
- C. During the process of backfilling, any timbering, sheeting, shoring, and sheet piling used to shore the excavation shall be carefully removed by the Contractor in such a manner as will result in a minimum of caving, lateral movement, or flowing of the soil. On approval by the District, the Contractor may leave in place sheet piling, sheeting, and bracing.
- D. Backfill shall be brought up evenly on all sides. Each layer of backfill material shall be thoroughly compacted using mechanical compacting equipment, rolling, or hand tamping. No subsequent lifts shall be placed until the previously compacted lift has been approved. If rolling is employed, it shall be with a suitable roller or tractor, being careful to compact the fill throughout the full width of the trench. Backfill material shall not be dropped directly upon the pipe.
- E. To prevent longitudinal movement of the pipe, dumping backfill material into the trench and then spreading will not be permitted until pipe bedding material has been placed and compacted to a level 1 foot over the pipe and backfill has been placed 1 foot above the bedding.
- F. Trench backfill around structures shall be structural fill material. All backfill shall be compacted, especially under and over pipes connected to structures.
- G. Subject to the approval of the District, fragments of rock and boulders smaller than 3 inches may be used in trench backfill providing that the quantity in the opinion of the District, is not excessive. Rock fragments, boulders, and unbroken masses of earthy materials larger than 3 inches shall not be placed in the trench until the pipe has at least 2 feet of earth cover. Fill shall not be dropped into the trench in a manner that would endanger the pipe.
- H. All trench backfill should consist of approved earth materials free of trash or debris, vegetation, or other deleterious matter. Compaction shall be through mechanical means. No jetting of backfill will be allowed under any conditions.
- I. Bituminous paving fragments shall not be placed in bedding or backfill material. Frozen material shall not be used under any circumstances.

- J. All roads outside of the Contractor's work area shall be clean and in a safe drivable condition for through- traffic at all times.
- K. All road surfaces (where applicable) shall be broomed and hose-cleaned and rebroomed if necessary immediately after backfilling. Roadway cleaning shall be to the satisfaction of the District.

### **3.06 EXCAVATION BELOW GRADE AND REFILL**

- A. In addition to the requirements noted in paragraph 3.01, whatever the nature of unstable material encountered or the groundwater conditions, trench drainage shall be complete and effective.
- B. If the Contractor excavates below grade through error or for their own convenience, or through failure to properly dewater the trench, or if they disturb the subgrade before dewatering is sufficiently complete, the Contractor may be directed by the District to excavate below grade as set forth in the following paragraph.
- C. If trench bottom material consists of fine sand, sand and silt or soft earth which may work into the screened gravel notwithstanding effective drainage, the subgrade material shall be removed to the extent acceptable to the District and the excavation refilled with a 6 inch layer of coarse sand, or a mixture graded from coarse sand to fine peastone, as approved by the District, to form a filter layer preserving the voids in the gravel bed of the pipe.
- D. Except as otherwise noted, where the trench bottom has been excavated below grade, a layer of structural fill material, moisture conditioned to optimum moisture content and compacted to at least 90 percent maximum dry density, shall be placed to bring the bottom of the excavation to grade.
- E. No compacting shall be done when either the previously placed or the new materials are too wet to obtain the compaction specified. At such times, the materials shall be removed and replaced with suitable material for compacting as specified, or work shall be suspended until the previously placed and new materials have dried sufficiently to permit proper compacting.

### **3.07 PLACEMENT OF PIPE BEDDING WITHIN THE PIPE ZONE**

- A. Pipe bedding shall be installed the full width of the trench extending from the depth shown on the Drawings below the underside of the pipe to a horizontal level surface at least 12 inches above the top of the pipe. The bedding shall contain no cinders or other material which may cause pipe corrosion. Screened gravel or sand as specified in Section 02230, shall be used for pipe zone bedding.

- B. The bedding shall be placed simultaneously on both sides and over the pipe in maximum 6 inch uncompacted lifts. Pipe bedding shall be spread and compacted and the surface graded to provide a uniform and continuous support beneath the pipe at all points between bell holes or pipe joints. It will be permissible to slightly disturb the finished subgrade surface by withdrawal of pipe slings or other lifting tackle.
- C. After each pipe has been graded, aligned, and placed in final position on the bedding material and shoved home, sufficient bedding shall be deposited and hand compacted under and around each side of the pipe and back of the bell or end thereof to hold the pipe in proper position and alignment during subsequent pipe jointing and bedding operations.
- D. Low points along the pipe trench shall not be backfilled until all backfill at adjacent higher elevations has been completed. Water collecting at the low points along the trench shall be removed by pumping or other approved means in order to avoid softening of adjacent natural ground. An adequate number of sump pumps at proper spacing shall be supplied to prevent the accumulation of excess water in the trench.
- E. Additional bedding shall then be deposited and compacted uniformly and simultaneously on each side of the pipe to prevent lateral displacement and to fill all spaces beneath the pipe.
- F. All pipe bedding shall be compacted to a minimum 90 percent of ASTM D1557 maximum dry density as acceptable to the District.

### **3.08 BACKFILLING ABOVE THE BEDDING**

- A. Where new work is installed in an existing street, street shoulder, a proposed future street, or under concrete, the trench zone above the bedding, from 12 inches above the top of the pipe up to the bottom of the specified permanent road base and asphaltic concrete pavement section or gravel road base shall be backfilled with structural fill material. Backfill within this zone shall be compacted in maximum 8 inch lifts to a minimum of 90 percent of ASTM D1557 maximum dry density.
- B. Where new Work is installed under open fields or landscaped areas, the trench zone above the bedding to the existing ground surface shall be backfilled with structural fill material placed in maximum 8 inch loose layers and compacted to at least 90 percent of ASTM D1557 maximum dry density.

### **3.09 COMPACTION**

- A. In all cases, backfill and compaction shall comply with the requirements of the local government agency having jurisdiction, which may be more severe than that required herein. Relative compaction shall be determined using AASHTO Test No. T180 (Standard Proctor) and appropriate field tests approved by the District. Specific compaction requirements are provided above in paragraphs 3.07 and 3.08.

- B. Compaction shall be by moisture conditioning with water and using mechanical compaction, rolling, or hand tamping methods.
- C. If rolling is employed, it shall be by use of a suitable roller or tractor, being careful to compact the fill throughout the full width of the trench. Where other methods are not practicable, compaction shall be by use of hand or pneumatic ramming with tools weighing at least 20 pounds. The method shall consist of one man ramming for each man shoveling backfill into the trench, the material being spread and compacted in layers not over 6 inches thick for bedding and 8 inches thick for backfill. If necessary, sprinkling shall be employed with rolling or ramming. If backfilling is done by machine, it shall be conducted in a manner to obtain results equal to those obtained by other methods described above. No pneumatic ramming tools shall be used to compact backfill for PVC.
- D. No jetting of backfill will be allowed under any conditions.

### **3.10 RESTORING TRENCH SURFACE**

- A. Where the trench occurs within an existing paved street section, the trench surface should be restored using aggregate base, paving materials, and methods of placement in accordance with Contra Costa County Specifications and Standard Plan Sheet CU01 unless superseded by City of Oakley requirements. Within the paved area of the roadway including the shoulder, curb/gutter and sidewalk areas, the minimum trench backfill shall match the existing structural section of the road or have a minimum of 300mm (12") of Class 2 aggregate base and 75mm (3.0") of asphalt concrete, whichever is greater. The minimum relative compaction of the Class 2 aggregate base and the asphalt concrete shall be 95 percent.
- B. Where the trench occurs adjacent to paved streets, in shoulders, sidewalks, or in cross-country areas, thoroughly consolidate the backfill and maintain the surface as the work progresses. If settlement takes place, immediately deposit additional fill to restore the level of the ground. Aggregate base, paving materials, and methods of placement shall be in accordance with Contra Costa County Standard Plan Sheet CU01.
- C. In and adjacent to streets, the top layers as noted on the Drawings of trench backfill shall consist of the appropriate sub-base material. Should the Contractor wish to use material excavated from the trench as gravel subways for pavement replacement, the Contractor, at their own expense, shall have samples of the material tested by an independent testing laboratory at intervals not to exceed 500 feet, in order to establish its compliance with the specifications. Only material which has been independently tested and then approved by the District shall be incorporated into the work.
- D. The surface of any driveway, gravel surface, or any other area which is disturbed by trench excavation and which is not a part of the paved road, shall be restored to a condition at least equal to that existing before work began.

- E. In sections where the pipeline passes through grassed areas, remove and replace the sod, or loam and seed the surface to the satisfaction of the District.
- F. Additional surface restoration requirements are on the Drawings and in other Sections of these Specifications.

### **3.11 TEMPORARY PATCHING**

- A. Temporary surfacing shall be Class 2 aggregate base, equal in depth to the existing pavement structural section but in any case, not less than 16 inches in depth, plus 1-1/2 inches of premixed asphaltic paving material.
- B. The aggregate base shall be given a penetration treatment as specified in section 36 of the above State Standard Specifications. Liquid asphalt used for the treatment shall be:
  - 1. Grade MC-70 or SC-70. The rate of application of the liquid asphalt shall be the maximum that will, under favorable weather conditions, be completely absorbed by the base material within 24 hours of the time of application. A sufficient amount of liquid asphalt shall be applied to bind the aggregate base and prevent raveling. Care shall be taken so that liquid asphalt is applied to the adjoining pavement surface.
- C. In areas used by public traffic, the temporary paving must be placed at the end of the work day. All other areas shall be surfaced within 2 days of backfilling.
- D. Before the street is opened for traffic, all excess dirt, rock, and debris shall be removed and the street surface shall be swept clean. Temporary surfacing shall be maintained constantly so no mud holes will occur, and surface shift of plus or minus 1 inch from the existing pavement shall occur.

### **3.12 TEST PITS**

- A. Excavation of test pits are required to locate underground utilities or structures.
- B. Test pits shall be backfilled as soon as the desired information has been obtained. The backfilled surface shall be maintained in a satisfactory condition for travel until resurfaced as specified or directed by the District.

## **PART 4      INSPECTION AND TESTING**

### **4.01    GENERAL**

- A.     Testing of materials for pipe trench bedding and backfill will be performed by the Contractor. The Contractor will perform tests of the materials to assure that the materials and placement operations are in compliance. The Contractor will conduct field density tests and other related laboratory testing on the compacted fill to determine the degree of compaction and other properties. In addition, concurrent with construction, Contractor will take samples of the fill and test them for moisture content and gradation, and carry out any other control or record tests which may be required.
- B.     At a minimum, the Contractor shall perform confirmation compaction testing for every 200 linear feet of pipeline in relatively uniform backfill and/or excavated soil, or 180 cubic yards of backfill. At each test location, the test should include each type or class of backfill utilized. The Contractor shall furnish labor and equipment to assist in obtaining samples for testing, such as blading flat surfaces for field density tests or excavation for shallow pits for sampling of fill materials in-place. Tests performed will be in accordance with the following procedures:
1.     Gradation: Caltrans Manual of Test, California Test No. 202.
  2.     Sand Equivalent: Caltrans Manual of Test, California Test No. 217.
  3.     Density and Moisture Content of Materials In-Place: Caltrans Manual of Test, California Test Nos. 216 or 231.
- C.     All pipe bedding, backfill, and other fill materials not meeting the testing requirements specified above shall be reworked or removed and replaced with material satisfactory to the District.

Related drawings:     DWD 1  
                                  DWD 4

END OF SECTION

## SECTION 02230

### FILL AND BACKFILL MATERIALS

#### **PART 1 GENERAL**

##### **1.01 SCOPE OF WORK**

- A. Furnish all labor, supervision, materials, equipment, testing, and incidentals necessary to provide the materials specified in this Section.

##### **1.02 DESCRIPTION**

- A. Fill, backfill, bedding, controlled density fill, and related materials (native and imported) are specified in this Section, but their uses are specified elsewhere and/or shown on the Drawings. The District may order the use of these materials for purposes other than those specified in other Sections and/or as shown on the Drawings.

##### **1.03 SUBMITTALS/QUALITY CONTROL**

- A. The Contractor shall submit to the District, reports of tests of individual materials to indicate that the materials meet these specifications, prior to the materials being used in the Work.
- B. All tests shall be in accordance with the most recent applicable ASTM or AASHTO standard test specifications.
  - 1. Grading – ASTM C117, ASTM C136
  - 2. Plasticity Index – ASTM D4318
  - 3. Sand Equivalent Value – California Test 217 (Caltrans)
- C. Controlled Density Fill
  - 1. The Contractor shall submit product data for the following:
    - a. Sources of cement, pozzolan, and aggregates.
    - b. Material Safety Data Sheets (MSDS) for all components and admixtures.
    - c. Admixtures: Product data including catalogue cut, technical data, storage requirements, product life, recommended dosage, temperature considerations, and conformity to ASTM standards.



2. The Contractor shall submit test reports for the following:
  - a. Sieve analysis, mechanical properties, and deleterious substance content for aggregates.
  - b. Chemical analysis and physical tests of cement and pozzolan.
  - c. Mix proposed including constituent quantities per cubic yard, water cementitious ratio, type and manufacturer of cement, mixture weight per cubic foot.
  - d. Subsidence and bleed water tests.
  - e. Compressive strength data at 7 and 28 days for controlled density fix mixture.
- D. Representative samples of all materials to be imported shall be submitted for approval of the District. Imported material shall not be utilized until it has been so approved.

#### **1.04 REFERENCE STANDARDS**

- A. Where references are noted, the latest version or edition shall be used.
- B. American Society for Testing and Materials:
  1. ASTM C33 – Standard Specification for Concrete Aggregates
  2. ASTM C117 – Standard Test Method for Materials Finer than 75-micrometers (No. 200) Sieve in Mineral Aggregates by Washing
  3. ASTM C136 – Standard Test Method for Sieve Analysis of Fine and Coarse Aggregates
  4. ASTM C150 – Standard Specification for Portland Cement
  5. ASTM C260 – Standard Specification for Air-Entraining Admixtures for Concrete
  6. ASTM C618 – Standard Specification for Coal Fly Ash and Raw or Calcined Natural Pozzolan for Use in Concrete
  7. ASTM C940 – Standard Test Method for Expansion and Bleeding of Freshly Mixed Grouts for Preplaced-Aggregate Concrete in the Laboratory
  8. ASTM D4318 – Standard Test Methods for Liquid Limit, Plastic Limit, and Plasticity Index of Soils

- C. California Department of Transportation
  - 1. California Test 217 – Method of Test for Sand Equivalent
  - 2. California Test 643 – Method for Estimating Service Life of Steel Culverts
  - 3. Standard Specifications Section 26 – Aggregate Bases

## **PART 2 PRODUCTS**

### **2.01 MATERIALS**

- A. Material to be used for engineered fill and backfill shall be free from organic matter and other deleterious substances, and of such quality that it will compact thoroughly without excessive voids when watered and rolled. Excavated on-site material will be considered suitable for engineered fill and backfill if it contains no more than 2 percent organic matter, is free of debris and other deleterious substances, and conforms to the requirements specified in this Section. Rocks of maximum dimension in excess of 6-inches shall be removed from any fill material to the satisfaction of the District.
- B. No material shall be used for trench backfill which, because of excessive moisture or any other reason, cannot be compacted to the degree specified. Any such material shall be considered unacceptable, and if it is deposited in the trench shall be removed and replaced with suitable material.
- C. All sieve sizes referenced are U.S. Standard sieve size unless otherwise noted. All percentages for amount passing a certain sieve are shown as a percentage of the total sample's weight.
- D. All materials noted herein shall have a maximum of 1 percent expansion when performed on a sample remolded to 95 percent of maximum ASTM D698 dry density and 2 percent below optimum moisture under a 100 psf surcharge.
- E. All materials furnished under this Section shall be non-hazardous and shall have a minimum resistivity of 5,000 ohm-cm and a minimum pH of 6.0 as measured by California Test 643. Refer to Section 16640 2.16.

### **2.02 BACKFILL MATERIAL (STRUCTURAL AND NON-STRUCTURAL AREAS)**

- A. This class of material shall be well graded, predominantly sandy gravel, less than 2 inches in any dimension, less than 2 percent of organic and inorganic debris, and shall contain less than 20 percent of mostly non-plastic fines passing the No. 200 sieve. The material shall have a liquid limit less than 30 and a plasticity index less than 12.

**2.03 CLASS 2 PERMEABLE MATERIAL**

- A. Class 2 permeable material, when required, shall conform to the following grading requirements:

<u>Sieve Size</u>	<u>Percentage Passing Sieve by Weight</u>
1-inch	100
3/4-inch	90 - 100
3/8-inch	40 - 100
#4	25 - 40
#8	18 - 33
#30	5 - 15
#50	0 - 7
#200	0 - 3

**2.04 SAND (PIPE BEDDING)**

- A. Sand shall be cleaned and washed inert natural sand, all passing a #4 U.S. standard sieve, and conforming to the fine aggregate requirements of ASTM C33.

**2.05 CONTROLLED DENSITY FILL**

- A. Materials
  1. Materials shall comply with these Specifications and any applicable state or local requirements.
  2. Cement: Type II domestic Portland cement complying with ASTM C150.
  3. Pozzolan (fly ash): Class F fly ash complying with ASTM C618. Pozzolan shall not inhibit the entrainment of air.
  4. Admixtures: Admixtures shall be free of chlorides and alkalis (except for those attributable to water).
    - a. Air entraining admixture shall comply with ASTM C260. Proportioning and mixing shall be in accordance with manufacturer's recommendations.
    - b. Stable air generator: Grace "Dara Fill" or approved equal.
  5. Aggregates: Aggregates shall conform with the requirements of ASTM C33. The amount of material passing a #200 sieve shall not exceed 12 percent by weight and no plastic fines shall be present. Aggregate shall be no larger than 3/8-inch. The 3/8-inch aggregate shall comprise less than 40 percent of the total aggregate content.

6. Water: Potable water free from injurious amounts of oil, acid, alkali, organic matter, or other deleterious substances.

**B. Mixture**

1. Controlled density fill mixture shall produce unconfined 28-day compressive strength, from 50 psi to a maximum of 150 psi.
2. Controlled density fill shall consist of a mixture of cement, pozzolan, sand, aggregate, air entraining agent, stable air generator, and water.
3. Controlled density fill shall have a minimal subsidence and bleed water of less than 1.0 percent (retains 99.0% of original height after placement) as measured in Section 10 of ASTM C940.
4. The unit weight shall be 90-115 pounds per cubic foot.
5. Consistency shall be flowable and self-leveling, with slump from 6 to 10 inches.

**C. Placement**

1. Place controlled density fill in a manner so that minimal segregation of the material occurs during and after placement, and without voids. Spade and vibrate as required to consolidate. Monitor placement to prevent flotation of pipes, structures, and other items.
2. For each truckload, provide documentation to the Engineer with the following clearly noted: design mix, date, truck number, quantity, and the supplier's name and address.
3. Protect the controlled density fill from traffic until sufficient strength has been achieved for further construction operations.

**2.06 AGGREGATE BASE**

- A. Aggregate base shall conform to the 2018 edition of Caltrans Standard Specifications, Section 26, Class 2 aggregate base,  $\frac{3}{4}$  inch maximum.
1. Type I backfill shall be well graded, granular material,  $\frac{1}{4}$  inch or less crushed rock, pea gravel, or other material approved by the District.
  2. Type II backfill shall be a material free of roots, organic matter, and other deleterious substances. Stones or lumps exceeding 1 inch in greatest dimension will not be permitted. The material shall have a plasticity index not exceeding 10 and an "R" value not less than 78 and shall be capable of being compacted as required. The material shall compact into a stable mass, and will not flow nor run whenever lateral support (such as the side of the trench) is removed.

3. Recycled concrete or asphalt shall not be used.

**PART 3 EXECUTION (NOT USED)**

Related drawings: DWD 1  
DWD 4  
DWD 17

END OF SECTION

## SECTION 02231

### JACK AND BORE

#### PART 1 GENERAL

##### 1.01 SCOPE OF WORK

- A. The Contractor shall furnish all plans, labor, supervision, equipment, materials, and incidentals required to install steel casings by boring and jacking as may be required to install pipelines as shown on the Drawings. This section specifies requirements for performing the boring and jacking operation.
- B. The Contractor shall continuously keep the jacking pit's subgrade free from ground and surface water during the operation and shall be prepared to implement groundwater control on short notice as directed by the District, even if observed water levels prior to construction are below the invert elevation of the casing pipe. Groundwater control shall include pumping, bailing, well pointing or chemical grout stabilization as required.
- C. The Contractor shall be fully responsible for inspecting the location where casing pipes are to be installed and familiarize him/herself with the conditions under which the work will be performed. The omission of any installation details which may not appear herein, shall not relieve the Contractor of full responsibility.
- D. The Contractor shall be prepared to work at night and on weekends or holidays, if required to complete this work. After the jacking operation has begun, and with the approval of the District, the Contractor shall work continuously (24 hours a day), if necessary, until the complete lengths of casings have been installed.
- E. If any movement or settlement occurs which causes or might cause damage to existing facilities or structures over, along, or adjacent to the work, the Contractor shall immediately stop any and all work except that which assists making the work secure and prevents further movement, settlement, or damage. The Contractor shall resume boring and jacking only after all necessary precautions have been taken to prevent further movement, settlement or damage, and shall repair the damage, at their own cost, to the satisfaction of the District.
- F. Construction shall be done in such a manner that will not interfere with the operation of any street or highway, nor weaken or damage any embankment or structure. Barricades and lights shall be furnished and maintained to safeguard traffic and pedestrians as directed by the District until such time as the operation has been completed.
- G. The Contractor shall obtain from the California Division of Occupational Safety and Health Administration and, as applicable, the California Division of Mines a preliminary gas classification for each bore 30 inches in diameter and larger. It shall be the Contractor's responsibility to see that the Work is done in conformance with all applicable Federal, State, and local safety requirements.

## 1.02 SUBMITTALS

- A. The Contractor shall submit the following:
  - 1. Manufacturer's product literature for steel casing, casing insulators, end seals, end seal mix design, and grout mix design.
  - 2. Casing installation schedules which include schedules of excavation, pipeline installation, and pit backfill operations.
  - 3. Detailed plans showing locations and sizes of all jacking and receiving pits, and work time schedules. The plan must be approved by the District.
  - 4. Welders certificates must be submitted, be current and approved for the type of welding to be performed.
  - 5. Qualifications of the boring and jacking Contractor include the following:
    - a. Name, business address, telephone number of Contractor.
    - b. Experience in successfully constructing water pipelines by boring and jacking or tunneling with steel pipes.
    - c. List of similar projects for the last 2 years, including name and telephone number of contact person.
    - d. Certification of workman equipment operation training.
    - e. Names and experience of all supervisory personnel to be directly involved with the project.

## 1.03 REFERENCE STANDARDS

- A. When references are made to standards, the most recent version or edition shall be used.
- B. California Code of Regulations (CCR) Title 8, Construction Safety Orders
- C. American Society of Materials and Testing (ASTM)
  - 1. ASTM C33 – Standard Specification for Concrete Aggregate
  - 2. ASTM A36 - Standard Specification for Carbon Structural Steel
  - 3. ASTM A53 - Standard Specification for Pipe, Steel, Black and Hot-Dipped, Zinc-Coated, Welded and Seamless
- D. American National Standards Institute (ANSI)
  - 1. ANSI/AWS D1.1 – Structural Welding Code – Steel

- E. AMERICAN WATER WORKS ASSOCIATION
  - 1. AWWA C206 – Field Welding of Steel Water Pipe
  - 2. AWWA C213 – Fusion-Bonded Epoxy Coatings and Linings for Steel Water Pipe and Fittings

#### **1.04 QUALITY ASSURANCE**

- A. All boring and jacking operations shall be done by a qualified Contractor with at least 5 years of experience involving work on steel lining installation in jacking and boring tunnels.
- B. The Contractor's design engineer shall be a registered civil or structural engineer in California with at least 5 years of experience in design of boring and jacking or tunneling operations with steel pipe.
- C. The Contractor's superintendent in charge of work shall have a minimum of 2 projects of equivalent size and complexity within the past 7 years.
- D. The Contractor's supervising field welder and inspector shall have a minimum of 3 years recent experience within the last 5 years with welding procedures required on this project.
- E. Welders shall be qualified under the provisions of ANSI/AWS D1.1. by an independent local, approved testing agency not more than 6 months prior to commencing work on the casing or pipeline. Machines and electrodes similar to those used in the Work shall be used in qualification tests. The Contractor shall furnish all materials and bear the expense of qualifying welders.
- F. All welding procedures used to fabricate and install steel casings shall be prequalified under the provisions of ANSI/AWS D1.1. Welding procedures shall be required for, but not necessarily limited to, longitudinal and girth or special welds for pipe cylinders, casing joint welds, reinforcing plates, and pressure grout coupling connections.

### **PART 2 PRODUCTS**

#### **2.01 MATERIALS**

- A. Steel casings shall be fabricated in accordance with ASTM A53 from steel plates having minimum yield strength of 36,000 psi and meeting the requirements of ASTM A36, and shall be epoxy coated in accordance with AWWA C213. Steel casing sleeves shall be of the diameter and thickness identified in the Drawings, and shall be furnished complete with welded joint ends that are watertight, and for pipes 24 inches and larger, pressure grout couplings. The Contractor, at their own expense, may select a greater diameter or thickness for the method of work and loadings involved, site conditions, and possible interferences.



- B. Mortar grout shall consist of one part Portland cement and two parts sand, and minimum amount of water to obtain the desired consistency. The grout mixtures shall contain 2 percent of bentonite by weight of the cement. Portland cement and water shall be as specified in Section 03600. Sand shall be of such fineness that 100 percent will pass a No. 8 sieve and at least 45 percent will pass a No. 40 sieve. Bentonite shall be commercially processed powdered bentonite, Wyoming type.
- C. Sand for casing fill shall meet the requirements of ASTM C33 for fine aggregates.
- D. Casing spacer insulators shall be Calpico Model W, or Williamson M-2. The spacer insulator "system" shall be designed and fabricated for the specific project and application for which they are furnished, including installation of carrier pipe in liner plate casing tunnels. All bands and other hardware on the spacers shall be Type 304 stainless steel. Insulator spacing shall be as indicated on the Drawings.
- E. Casing End Closures
  - 1. Mortar shall be Burke non-ferrous, non-shrink grout, or equal, with pea gravel.
  - 2. Pre-fabricated rubber and seals may be used with the District's approval.

## **PART 3 EXECUTION**

### **3.01 JACKING PITS**

- A. The location of jacking pits shall be approved by the District.
- B. All jacking pits shall be protected with suitable fencing or barricades to prohibit unauthorized access to the work site.
- C. The pits shall be shaped with heavy timber or steel sheet piling or other suitable materials that shall be of adequate strength. Braced steel or heavy timber sheeting shall be used to support the sides of the excavation for the pits.
- D. The Contractor shall furnish, install and remove, to the extent required, thrust blocks or whatever provisions may be required for driving the casings/sleeves and pipes forward.
- E. Steel rails or beams embedded in concrete shall be used in the pit for placement and alignment of each piece of casing/sleeve or pipe during installation operations.
- F. The Contractor shall be fully responsible for the removal of the pits, including the breaking-up, removing, and disposing of concrete, if so required, or cutting-off of sheeting and furnishing and placing the backfill to the normal subgrade as may be required following the installation operations.
- G. The pits or trenches excavated to perform boring, tunneling and jacking operations shall be backfilled and compacted per Section 02210 immediately after jacking, pipe installation, grouting and filling has been completed.

- H. The Contractor shall provide fans, blowers or other devices necessary to ensure adequate ventilation for workers in the casing, tunnel or boring excavations.
- I. The Contractor shall provide adequate lighting devices and generator sets as necessary for workers and inspectors in the casing, tunnel and boring excavations.

### **3.02 BORING**

- A. A true, circular tunnel shall be cut to the required line and grade. Bored tunnels shall be no more than 4 inches larger than the outside diameter of the casing pipe to be installed.
- B. Excavated material shall be placed at a distance from the working pit and used as backfill upon completion of casing and carrier pipe installation. The use of water or other fluids in connection with the boring operation will be permitted only to the extent necessary to lubricate cuttings. Water jetting will not be permitted.
- C. Where material in the bore is sandy or unstable and will be subject to caving, the casing hole shall be bored and cased simultaneously, and the bored material removed through the casing. The cutting face of auger or drill shall not project more than 6 inches ahead of casing.
- D. Where material in the bore is stable and not subject to caving, the hole for the casing may be bored first and casing jacked into the hole immediately after completion of boring if permitted by the District.

### **3.03 JACKING OPERATIONS**

- A. Heavy duty jacks suitable for forcing the casing or carrier pipe through the embankment or casing pipe opening shall be provided. In operating jacks, even pressure shall be applied to all jacks used. A suitable jacking head of timber, and suitable bracing between jacks and jacking head shall be provided so that pressure will be applied to the casing or carrier pipe uniformly around the ring of the casing or carrier pipe. A suitable jacking frame or back stop shall be provided. The casing or carrier pipe to be jacked shall be set on guides, properly braced together to support the section of the casing or carrier pipe and to direct it in the proper line and grade. The whole jacking assembly shall be placed so as to line up with the direction and grade of the casing pipe.
- B. The casing or carrier pipe shall be jacked from the low or downstream end. The maximum deviation of casing pipe from the grade and line shown on the Drawings shall be such that the line and grade of the carrier pipe can be adjusted within the casing pipe and still maintain the line and grade along its full length. Carrier pipe shall not deviate more than 0.33 feet per 100 feet from the line and grade shown, provided that such variation shall be regular and continuous only (no bows or reverse curve sections) in one direction and that the final grade of flow line shall be in the direction indicated on the Drawings.

- C. When jacking of casing pipe is initiated, the operation shall be continued without interruption, insofar as practicable, to prevent the pipe from becoming firmly set in the embankment.
- D. Excavated materials shall be removed from the casing as the boring or jacking operation progresses and no accumulation of excavated materials within the casing shall be permitted.
- E. Any casing or carrier pipe damaged in jacking operations shall be removed and replaced by the Contractor at their expense.
- F. Steel casing sections shall be field butt welded in accordance with the applicable portions of AWWA C206 and AWS D7.0 for field welded water pipe joints. The welded joints shall be wire brushed and painted with Koppers Inertol Quick-Drying Primer 626 primer manufactured by Tnemec Company Inc., or approved equal.

### **3.04 GROUTING**

- A. All space between the casing pipe and the bored excavation shall be pressure filled with grout immediately upon the complete installation of the casing.
- B. Casing sleeves for jacking shall have grout holes equipped with pipe half-couplings. The 2 inch standard pipe half-couplings welded into the holes in the casing walls shall be filled with threaded cast iron bolt plugs. Bolt plugs shall be no less than 5/8 inch diameter. Three grout holes spaced at 120 degrees on center shall be installed with each set of three being not more than 10 feet apart along the casing. Shop drawings showing details of the casings, size and length of bolts, section modulus in inches cubed per inch of width and pipe thickness shall be furnished by the Contractor for review by the District.
- C. Systems of standard pipe, fittings, hose and special grouting outlets, embedded in the sleeve walls shall be provided by the Contractor. Care shall be taken to insure that all parts of the system are maintained free from dirt. Cement grout shall be forced under pressure into the grouting connections. Grouting shall be started in the lowest connections and shall proceed until grout begins to flow from upper connections.
- D. Apparatus for mixing and placing grout shall be of type approved by the District and shall be capable of mixing effectively and stirring the grout and then forcing it into the grout connections in a continuous uninterrupted flow.
- E. After grouting is complete, pressure shall be maintained by means of stop cocks, or other suitable devices, until the grout has set sufficiently. After the grout is set, grout holes shall be completely filled with dense concrete and finished neatly without evidence of voids or projections.

### **3.05 INSTALLING CARRIER PIPE**

- A. After the casing has been completely installed, the Contractor shall thoroughly clean the interior of the casing. Contractor shall place the carrier pipe within the casing using casing spacer insulators. These methods, or modifications thereof, as approved by the District, shall be employed for the construction of all cased crossings.
- B. After the carrier pipe is installed within the casing and prior to the placement of sand fill or grout, the Contractor shall conduct the required pressure and leakage test on the carrier pipe. Any leaks which are discovered during the testing phase shall be repaired to the satisfaction of the District.
- C. The carrier pipe shall be installed to the exact line and grade required within the casing, and, after it has been satisfactorily placed and approved by the District, the space between the outside of the pipe and the casing shall be completely filled with sand blown in one continuous uninterrupted operation in a manner to prevent occurrence of any voids between carrier pipe and casing. Each joint of carrier pipe must be braced to sides and top of casing to prevent flotation or motion during the placing of sand. The casing spacer insulators shall be installed on the carrier pipe per the manufacturer's instructions prior to inserting the carrier pipe into the casing. Altered insulators shall not be used.
- D. The annular space at each end of the casing shall be packed with mortar to seal the casing. The mortar closure shall extend a minimum of 12 inches into the casing. If approved by the District, a rubber casing seal may be used to close the ends of the casing.

### **3.06 PERMANENT MARKING**

- A. Contractor shall place permanent markers or signs at the ends of the casing pipe indicate the location of the buried pipeline.

Related drawings: DWD 5

END OF SECTION

## SECTION 02512

### STEEL PIPE AND FABRICATED SPECIALS

#### PART 1 GENERAL

##### 1.01 SCOPE OF WORK

- A. The Contractor shall provide all materials, equipment, and labor and supervision necessary to furnish and install cement mortar lined and coated steel pipe and specials, complete and operable, including all connections as shown on the Drawings and as specified herein.
- B. Specials are defined as fittings, closure pieces, correction pieces, bends, reducers, nozzles, wyes, tees, crosses, outlets, manifolds and other steel plate specials.
- C. All steel pipe shall be cathodically protected per Section 16640 and the Drawings.
- D. Connections to existing steel spiral wrapped pipe shall be designed by a registered Civil Engineer and submitted to the District for review.

##### 1.02 REFERENCE SPECIFICATIONS, CODES, AND STANDARDS

- A. Referenced standards shall be the most recent version or edition.

AASHTO	Standard Specifications for Highway Bridges
ANSI/AWS D1.1	Structural Welding Code- Steel
ASTM A36	Standard Specification for Carbon Structural Steel
ASTM A139	Standard Specification for Electric-Fusion (Arc)-Welded Steel Pipe (NPS 4 and Over)
ASTM A283	Standard Specification for Low and Intermediate Tensile Strength Carbon Steel Plates
ASTM A572	Standard Specification for High-Strength Low-Alloy Columbium-Vanadium Structural Steel
ASTM A1011	Standard Specification for Steel, Sheet and Strip, Hot-Rolled, Carbon, Structural, High-Strength Low-Alloy, High-Strength Low-Alloy with Improved Formability, and Ultra-High Strength
ASTM C150	Specification for Portland Cement
ASTM E709	Standard Guide for Magnetic Particle Testing
AWWA C200	Steel Water Pipe, 6 In. (150 mm) and Larger
AWWA C205	Cement-Mortar Protective Lining and Coating for Steel Water Pipe – 4 In. (100 mm) and Larger - Shop Applied

AWWA C206	Field Welding of Steel Water Pipe
AWWA C207	Steel Pipe Flanges for Waterworks Service, Sizes 4 In. Through 144 In. (100 mm Through 3,600 mm)
AWWA C208	Dimensions for Fabricated Steel Water Pipe Fittings
AWWA C602	Cement-Mortar Lining of Water Pipelines in Place – 4 In. (100 mm) and Larger
AWWA MANUAL M11	Steel Pipe - A Guide for Design and Installation

### 1.03 CONTRACTOR SUBMITTALS

- A. Shop Drawings: The Contractor shall submit shop drawings of pipe and fittings in accordance and the following supplemental requirements:
1. Joint and pipe fitting wall construction details which indicate the type and thickness of cylinder, the position, type, size and area of reinforcement, manufacturing tolerances, and all other pertinent information required for the manufacture of the product. Joint details shall be submitted where butt strap joints are required.
  2. Fittings and special details such as elbows, wyes, tees, outlets, connections, test bulkheads, and nozzles or other specials where shown, which indicate amount and position of all reinforcement. All fittings and specials shall be properly designed to withstand the internal pressure, both circumferential and longitudinal, and the external loading conditions as indicated in the approved design calculations.
  3. Design calculations including a complete stress analysis of each critical section of pipe wall, girth joints, and specials - all sufficient to ascertain conformance of pipe and fittings with these Specifications.
  4. Material lists which include and describe all materials to be utilized.
  5. Full and complete information regarding location, type, size and extent of all welds shall be shown on the shop drawings. The shop drawings shall distinguish between shop and field welds. Shop drawings shall indicate by welding symbols or sketches the details of the welded joints and the preparation of parent metal required to make them. Joints or groups of joints in which welding sequence or technique are especially important shall be carefully controlled to minimize shrinkage stresses and distortion.
- B. Certificate of Compliance: Certificates of Compliance shall be provided for all products and materials proposed to be used under this Section, as specified in AWWA C200 and AWWA C205, respectively, and the following supplemental requirements:
1. Physical and chemical properties of all steel.
  2. Hydrostatic test reports.

3. Results of production weld tests.

## **1.04 QUALITY ASSURANCE**

- A. Tests: Except as modified herein, all materials used in the manufacture of the pipe shall be tested in accordance with the requirements of AWWA C200 and AWWA C205, as applicable.
  1. After the joint configuration is completed, each length of pipe of each diameter and pressure class shall be shop-tested and certified to a pressure of at least 80 percent of the yield strength of the pipe steel.
  2. In addition to the tests required in AWWA C200, weld tests shall be conducted on each 5,000 feet of production welds and at any other times there is a change in the grade of steel, welding procedure, or welding equipment.
- B. The District shall have the right to witness all testing conducted by the Contractor; provided, that the Contractor's schedule is not delayed for the convenience of the District.
- C. In addition to those tests specifically required, the District may request additional samples of any material including mixed concrete and lining and coating samples for testing by the District.
- D. Welding Requirements: All welding procedures used to fabricate pipe shall be prequalified under the provisions of ANSI/AWS D1.1. Welding procedures shall be required for, but not necessarily limited to, longitudinal and girth or spiral welds for pipe cylinders, spigot and bell ring attachments, reinforcing plates and ring flange welds and plates for lug connections.
- E. Welder Qualifications: All welding shall be done by skilled welders, welding operators and tackers who have had adequate experience in the methods and materials to be used. Welders shall be qualified under the provisions of ANSI/AWS D1.1 by an independent local, approved testing agency not more than 6 months prior to commencing work on the pipeline. Machines and electrodes similar to those used on the project shall be used in qualification tests.

## **PART 2 PRODUCTS**

### **2.01 GENERAL**

- A. Steel pipe shall be cement mortar coated in accordance with AWWA C205. All linings and coatings shall be shop applied.
- B. Steel pipe with mortar-lining and/or mortar-coating shall conform to AWWA C200 and AWWA C205, subject to the following supplemental requirements:

1. The pipe shall be of the diameter and class shown on the Drawings, shall be furnished complete with welded joints, and all specials and bends shall be provided as specified or required.
  2. The inside diameter after lining shall not be less than the nominal diameter specified or shown.
- C. Marking: The Contractor shall insure all pipes and specials are legibly marked in accordance with the laying schedule and marking diagram. Each pipe shall be numbered in sequence and said number shall appear on the laying schedule and marking diagram in its proper location for installation. All special pipe sections and fittings shall be marked at each end with top field centerline.
- D. Laying Lengths: Maximum pipe laying lengths shall be 40 feet with shorter lengths provided as required by the design and Shop Drawings.
- E. Offset Tolerances: For pipe wall thicknesses of 3/8 inch or less, the maximum radial offset (misalignment) for submerged arc and gas metal arc welded pipe shall be 0.1875 times the pipe wall thickness or 1/16 inch, whichever is larger. For pipe wall thickness of greater than 3/8 inch, the maximum radial offset shall be 0.1875 times the wall thickness or 5/32 inch, whichever is smaller.
- F. Mortar Lining: The pipe mortar lining shall have smooth dense interior surfaces and shall be free from fractures, excessive interior surface crazing and roughness.
- G. Bonding and Electrical Conductivity: All unwelded pipe joints shall be bonded for electrical conductivity in accordance with the approved cathodic protection system design. Insulated joints shall be provided as required by the approved cathodic protection system design.
- H. Closure and Correction Pieces: Closure and correction pieces shall be provided as required so that closures may be made due to different headings in the pipe laying operation and so that correction may be made to adjust the pipe laying to conform to pipe stationing shown on the Drawings. Any change in location or number of said items must be approved by the District.

## **2.02 PIPE DESIGN**

- A. General: The pipe furnished shall consist of a steel cylinder, shop-lined with cement-mortar and shop-coated with an exterior coating of cement-mortar.
- B. Design: Except as otherwise provided herein, materials, fabrication and shop testing of straight pipe shall conform to the requirements of AWWA C200.
- C. Pipe Dimensions: The pipe shall be of the diameter and class shown on the Drawings. Steel pipe dimensions represent the ultimate pipe inside diameter after lining.
- D. Fitting Dimensions: The fittings shall be of the diameter and class shown on the Drawings. Fabricated fittings shall conform to the dimensions of AWWA C208.



- E. Joint Design: Unless otherwise specifically required on the Drawings, the standard field joint for steel pipe shall be a split butt-strap joint. Flanged joints shall be required where shown on the Drawings. The joints furnished shall have the same or higher pressure rating as the abutting pipe. All connections between steel and ductile iron pipe shall be electrically separated by an insulated flange or insulated mechanical coupling per Section 16640.
- F. Restrained Joints: All joints on steel pipe shall be welded joints. Designs shall include considerations of stresses induced in the steel cylinder, the joint rings and any field welds caused by thrust at bulkheads, bends, reducers and line valves resulting from the design working pressure. For field welded joints, design stresses shall not exceed 50 percent of the specified minimum yield strength of the grade of steel utilized, or 16,500 psi, whichever is less, for the part being examined when longitudinal thrust is assumed to be uniformly distributed around the circumference of the joint. All field welded joints shall have the joint rings attached to the cylinder with double fillet welds. Welding inspections shall be done by DWD approved Inspector and paid for by Owner/Developer.

### **2.03 FABRICATION AND MATERIALS**

- A. Cement: Cement for mortar shall conform to the requirements of AWWA C205; provided, that cement for mortar coating shall be Type V and mortar lining shall be Type II or V. Fly ash or pozzolan shall not be used as a cement replacement.
- B. Steel for Cylinders and Fittings: Pipe manufactured shall be fabricated from steel sheets or plate in accordance with AWWA C200. Fabrication from steel plate shall conform to ASTM A36; A 283, Grades C or D; or ASTM A 572, Grade 42 or coil conforming to the requirements of ASTM A 139, Grades B or C. All longitudinal and girth seams, whether straight or spiral, shall be butt welded using an approved electric-fusion-weld process.
- C. All steel used for the fabrication of pipe shall have a maximum carbon content of 0.25 percent and shall have a minimum elongation of 22 percent in a 2-inch gage length.
- D. Welding of Joint Rings to Resist Thrust: Where steel pipe with field-welded separate formed joint rings are used for thrust restraint, the joint rings shall be welded to the cylinder with double fillet welds.

### **2.04 PIPE FITTINGS AND SPECIALS**

- A. General: Reinforcement for closure and correction pieces, bends, reducers, nozzles, wyes, tees, crosses, outlets, manifolds and other steel plate specials shall be designed in accordance with AWWA Manual M-11. Reinforcement shall be designed for the design pressure specified or shown and shall be in accordance with the design details shown. Specials and fittings shall be equal in pressure design strength and shall have the same lining and coating as the adjoining pipe. Unless otherwise shown, the minimum radius of elbows shall be 2.5 times the pipe diameter and the maximum miter angle on each section of the elbow shall not exceed 11-1/4 degrees.

- B. All threaded outlets shall be forged steel suitable for 3,000 psi service per ASTM A105 or ASTM A216, and shall be as manufactured by Bonnie Forge Co., "Threadolet," Allied Piping Products Co., "Branchlet" or equal.
- C. Moderate deflections and long radius curves may be made by means of beveled joint rings, by pulling standard joints, by using short lengths of pipe, or a combination of these methods; provided that pulled joints shall not be used in combination with bevels. The maximum total allowable angle for beveled joints shall be 5 degrees per pipe joint. Bevels shall be provided on the bell ends. Mitering of the spigot ends will not be permitted. The maximum allowable angle for pulled joints shall be in accordance with the manufacturer's recommendations or the angle which results from a 3/4 inch pull out from normal joint closure, whichever is less. All horizontal deflections or fabricated angles shall fall on the alignment. In congested areas or at locations where underground structures are encountered, the chord produced by deflecting the pipe shall be no further than 6 inches from the alignment shown.
- D. All vertical deflections shall fall on the alignment and at locations adjacent to underground obstructions, points of minimum earth cover, and pipeline outlets and structures, the pipe angle points shall match the angle points shown.
- E. Outlets, Nozzles, Tees, Wyes, and Crosses: All outlets 12 inch and smaller may be fabricated from Schedule 30 or heavier steel pipe in the standard outside diameters, i.e., 12-3/4 inch, 10-3/4 inch, 8-5/8 inch, 6-5/8 inch, and 4-1/2 inch.
- F. The design of outlet reinforcement shall be in accordance with the procedures given in Chapter 13 of AWWA Manual M-11, except that the design pressure,  $P$ , used in the AWWA Manual M-11 procedure shall equal the greater of  $1.25 P_w$  or  $0.9375 P_t$ . Unless otherwise shown outlets 2 inches in diameter and smaller, Weld-O-Let as specified in Section 15105, "Miscellaneous Piping, Valves, Fittings and Appurtenance," need not be reinforced.
- G. In lieu of saddle or wrapper reinforcement as provided by the design procedure in AWWA Manual M-11, pipe or specials with outlets may be fabricated in their entirety of steel plate having a thickness equal to the sum of the pipe wall plus the required reinforcement.
- H. Where required by the AWWA Manual M-11 design procedure crotch plate reinforcement shall be furnished.
- I. Steel Welded Fittings: Steel welded fittings shall conform to ASTM A234.
- J. Ends for Mechanical-Type Couplings: Except as otherwise provided herein, where mechanical-type couplings are indicated, the ends of pipe shall be banded with Type C collared ends using double fillet welds.

## 2.05 CEMENT MORTAR LINING

- A. Cement-Mortar Lining for Shop Application: Except as otherwise specified, interior surfaces of all steel pipe, fittings, and specials shall be cleaned and lined in the shop with cement-mortar lining applied centrifugally in conformity with AWWA C205. If a special cannot be lined centrifugally, it shall be lined by hand. During the lining operation and thereafter, the pipe shall be maintained in a round condition by suitable bracing or strutting.
- B. The nominal lining thickness shall be in accordance with DWD5, DWD6, and DWD7. The pipe shall be designed for deflection using the nominal lining thickness.
- C. The exterior of pipe ends shall be left bare where field joints occur per DWD5. Ends of the linings shall be left square and uniform. Feathered or uneven edges will not be permitted.
- D. Defective linings shall be removed from the pipe wall and shall be replaced to the full thickness required. Defective linings shall be cut back to a square shoulder in order to avoid feather edged joints.
- E. The progress of the application of mortar lining shall be regulated in order that all hand work, including the repair of defective areas is cured in accordance with the provisions of AWWA C205. Cement-mortar for patching shall be the same materials as the mortar for machine lining, except that a finer grading of sand and mortar richer in cement shall be used when field inspection indicates that such mix will improve the finished lining of the pipe.
- F. Cement-Mortar Lining for Field Application: The materials and design of in-place cement-mortar lining shall be in accordance with AWWA C602 and the following supplementary requirements:
  - 1. Admixtures shall contain no calcium chloride.
  - 2. The minimum lining thickness shall be as specified for shop-applied cement-mortar lining and finished inside diameter after lining shall be as shown on the Drawings.
- G. Protection of Pipe Lining: For all pipe and fittings with shop-applied cement-mortar linings, a polyethylene or other suitable bulkhead shall be provided on the ends of the pipe and on all special openings to prevent drying out of the lining. All bulkheads shall be substantial enough to remain intact during shipping and storage until the pipe is installed.
- H. Use only NSF 61 approved materials for cement-mortar lining for field, shop, and repair applications.

## **2.06 EXTERIOR COATING**

- A. All pipe for buried service, including bulkheads, shall be coated with cement-mortar coating, with thickness as shown on the Drawings and tolerances in conformance with AWWA C205. The coating shall be reinforced in accordance with AWWA C205.

## **PART 3 EXECUTION**

### **3.01 INSTALLATION OF PIPE**

- A. When the pipe is being laid, it shall be turned and placed where possible, so that any slightly damaged coating portion will be on top. The damaged area shall be repaired. All interior or exterior damaged areas shall be repaired using materials and methods in accordance with AWWA C205.
- B. Pipe shall be laid directly on the bedding material. No blocking will be permitted, and the bedding shall be such that it forms a continuous, solid bearing for the full length of the pipe. Excavations shall be made as needed to facilitate removal of handling devices after the pipe is laid. Bell holes shall be formed at the ends of the pipe to prevent point loading at the bells or couplings. Excavation shall be made as needed outside the normal trench width at field joints to permit adequate access to the joints for field connection operations and for application of coating on field joints.
- C. Vertical or horizontal grade changes, where approved by the District, may be made by the deflection of joints or by the use of bevel adapters. In no case shall the deflection in the joint exceed the maximum deflection recommended by the pipe manufacturer. No joint shall be misfit any amount which will be detrimental to the strength and water tightness of the finished joint.

### **3.02 WELDED JOINTS**

- A. General: Field welded joints shall be in accordance with AWWA C206.
- B. Where exterior welds are performed, adequate space shall be provided for welding and inspection of the joints.
- C. Butt straps shall be a minimum of 6-inches wide, the same thickness as the pipe wall and shall provide for a minimum of 3/4-inch lap at each pipe joint.
- D. To control temperature stresses, the unbackfilled joint areas of the pipe shall be shaded from the direct rays of the sun by the use of properly supported awnings, umbrellas, tarpaulins, or other suitable materials for a minimum period of 2 hours prior to the beginning of the welding operation and until the weld has been completed. Shading materials at the joint area shall not rest directly on the pipe but shall be supported to allow air circulation around the pipe. Shading of the pipe joints need not be performed when the ambient air temperature is below 45 degrees F.

- E. Prior to the beginning of the welding procedure, any tack welds used to position the pipe during laying shall be removed. The weld shall then be made in accordance with AWWA C206. Where more than one pass is required, each pass except the first and final one shall be peened to relieve shrinkage stresses; and all dirt, slag, and flux shall be removed before the succeeding bead is applied.
- F. As soon as practicable after welding of each joint, all field-welded joints shall be tested in accordance with AWWA C200, by NSF approved wet magnetic particle testing of welds. All defects shall be chipped out, rewelded and retested. Upon retest, the repaired area shall show no leaks or other defects.
- G. Following tests of the joint, the exterior joint spaces shall be coated, and interior linings shall be repaired in accordance with these specifications.
- H. Qualifications of Procedures and Welders: All welding procedures used to install pipe shall be prequalified under provisions of ANSI/AWS D1.1. Welding procedures shall be required for field attachments and field welded joints. Copies of welders' certificates shall be provided to the District.

### **3.03 JOINT COATING**

- A. General: The interior and exterior joint recesses shall be thoroughly wiped clean and all water, loose scale, dirt and other foreign material shall be removed from the inside surface of the pipe. Grout for joint coating shall be non-shrink grout as allowed by AWWA C205 and specified in Section 03600, "Grout."
- B. The interior lining of all cement mortar lined and coated pipe at field welded joints and bell and spigot joints shall be repaired by buttering the inside of the joint, pushing the pipe ends together, and then pulling a burlap wrapped ball through the joint which forces the mortar up into the joint creating a seamless mortar lining at the joint between the shop applied mortar lining of both pipe segments.
- C. Handholes, consisting of threaded 5-inch half-couplings with full thickness steel plugs, shall not be permitted unless directed otherwise by the Engineer to perform interior lining repairs and mortar lining of the interior surface at all closure locations. The bottom of the plug shall be coated with an NSF-approved epoxy prior to installation, and welded in place around the threads after installation.
- D. Unless otherwise directed by the Owner, all cement mortar lining repairs shall be allowed to cure for a minimum of 4 hours before performing backfilling operations to avoid delamination of mortar lining repair due to vibration from compaction activities.

### **3.04 INSTALLATION OF PIPE APPURTENANCES**

- A. Protection of Appurtenances: Where the joining pipe is concrete or coated with cement mortar, buried appurtenances shall be coated with a minimum thickness of one inch of cement mortar having one part cement to not more than 2 parts plaster sand.

- B. Installation of Flanged Joints: Before the joint is assembled, the flange faces shall be thoroughly cleaned of all foreign material with a power wire brush. The gasket shall be centered and the connecting flanges drawn up watertight without unnecessarily stressing the flanges. All bolts shall be tightened in a progressive diametrically opposite sequence and torqued with a suitable, approved and calibrated torque wrench. All clamping torque shall be in conformance with the manufacturers printed recommendations and shall be applied to the nuts only.
- C. All buried flanges shall be coated by a shop applied epoxy coating.
- D. Insulated Joints: Insulated joints and appurtenant features shall be made by the Contractor as shown on the Drawings or as required by the approved cathodic protection system design. The Contractor shall exercise special care when installing these joints to prevent electrical conductivity across the joint. After the insulated joint is completed, an electrical resistance test will be performed by the Contractor and the results will be submitted to the District. Should the resistance test indicate a short circuit, the Contractor shall remove the insulating units to inspect for damages, replace all damaged portions and reassemble the insulating joint. The insulated joint shall then be retested to assure proper insulation.
- E. Flexible Coupled Joints: When installing flexible couplings, care shall be taken that the connecting pipe ends, couplings and gaskets are clean and free of all dirt and foreign matter with special attention being given to the contact surfaces of the pipe, gaskets and couplings. The couplings shall be assembled and installed in conformity with the recommendation and instruction of the coupling manufacturer. Sleeve type coupling shall conform to the requirements of Section 15100, "Valves and Appurtenances."
- F. Wrenches used in bolting couplings shall be of a type and size recommended by the coupling manufacturer. Coupling bolts shall be tightened so as to secure a uniform annular space between the follower rings and the body of the pipe with all bolts tightened approximately the same amount. Diametrically opposite bolts shall be tightened progressively and evenly. Final tightening shall be done with a suitable, approved and calibrated torque wrench set for the torque recommended by the coupling manufacturer. All clamping torque shall be applied to the nut only.
- G. Upon completion of the coupled joint, the coupling and bare metal of the pipe shall be cleaned, primed and epoxy coated.
- H. Installation of warning tape shall be in conformance with the Drawings.

### **3.05 CORROSION CONTROL**

- A. Corrosion control shall be provided on all steel pipelines and shall conform to the requirements of Section 16640, "Corrosion Control Requirements."

### **3.06 TESTING AND DISINFECTION**

- A. Field testing and disinfection of all steel pipe shall conform to the requirements of Section 02675, "Water Pipeline Testing and Disinfection."

Related drawings: DWD 5  
DWD 6  
DWD 7

END OF SECTION

## SECTION 02522

### GROUNDWATER MONITORING WELL

#### PART 1 GENERAL

##### 1.01 SCOPE OF WORK

- A. Furnish all labor, materials, equipment and incidentals required, to construct and develop groundwater monitoring wells to be used to monitor zone specific groundwater levels and to collect depth specific water samples for analysis. All work performed under this section will be coordinated with the Diablo Water District (District).
- B. The work to be completed by the Contractor generally includes the following:
  - a. Drilling a test hole, collecting lithologic samples, and perform geophysical surveys
  - b. Reaming the test hole to accommodate the installation of monitoring wells
  - c. Installation of monitoring wells, gravel pack, zone isolation seals, and annular seal
  - d. Installation of protective well head enclosure
  - e. Development of monitoring well
  - f. Installation of telemetered water level monitoring equipment

##### 1.02 PRELIMINARY MONITORING WELL DESIGN

- A. Conceptual, preliminary monitoring well designs are depicted in the Plans. Up to three monitoring wells may be installed in each reamed test hole each site with a combination of intermediate and surface seals as shown conceptually on the preliminary design.
- B. The monitoring well assemblies will be equipped with appropriate centralizers to ensure that the screen intervals are adequately spaced from the borehole wall.
- C. A graded gravel envelope, a fine sand transition seal, and a cement annular seal will be placed in each well via the tremie pipe method.
- D. The monitoring wells will be housed in an at grade vault.
- E. Each monitoring well will be equipped with telemetered, automated water level measuring equipment, that is compatible with the District's current telemetry and data management system.



### **1.03 NUISANCE WATER, DRILLING FLUIDS, DEVELOPMENT WATER, AND DRILL CUTTING**

- A. Nuisance water, such as rainfall or surface runoff, may occur at the well site(s). The Contractor shall protect the well site(s) from damage by such waters.
- B. All fluids generated by the drilling, construction, and well development process shall be contained in tanks, bins, or trucks and lawfully disposed off-site. No fluids shall be discharged to the ground. Transportation and disposal costs shall be the responsibility of the Contractor.
- C. All cuttings generated as part of the drilling process shall be contained in tanks, bins, or trucks. The Contractor shall take full ownership of drill cuttings generated and be responsible for handling and proper offsite disposal.

### **1.04 SUBMITTALS**

- A. Submit, shop drawings and product data required to establish compliance with the Section. Submittals shall include the following:
  - 1. A complete list of construction materials and supplies, including the name of the manufacturer, for the following:
    - a. casing
    - b. well screen
    - c. sand pack
    - d. bentonite seal
    - e. grout
    - f. caps and protective steel cover
    - g. cement grout sealing material
    - h. centralizers
    - i. drilling fluid additives
  - 2. The source and location of potable water supply, written authorization of the suppliers, method of transporting and containing the potable water. The Contractor shall employ means to prevent cross contamination of the water source (backflow preventer, air gap).
  - 3. The method of drilling fluid disposal.
  - 4. Shop drawings for the protective steel cover.
  - 5. Material samples of the sand pack.

6. The method for obtaining water samples.
- B. During drilling of each borehole, the Contractor shall maintain a complete log at the monitoring well site setting forth the following:
1. Reference point for all depth measurements
  2. Depth at which each change of formation occurs
  3. Identification of the material of which each stratum is composed
  4. Depth interval from which formation samples were taken
  5. Depth at which hole diameters (bit sizes) change
  6. Other pertinent data requested by the District.
- C. During drilling of each borehole, one (1) set of formation samples shall be collected, and preserved immediately after retrieval in a manner approved by the District. Samples shall be clearly and indelibly labeled with the following information:
1. Name or number of the borehole
  2. Location of the borehole
  3. Depth interval represented by the sample
  4. Date taken
- The samples will be delivered to the District upon completion of the monitoring well.
- D. The Contractor shall submit to the District for approval, certificates of compliance for the following materials:
1. Cement Grout Sealing Material
  2. Blank Well Casing
  3. Well Screen
  4. Gravel Envelope Material

- E. Certificates of compliance from the Contractor, suppliers, and/or manufacturers, shall clearly indicate that the material to be delivered to the job site will meet all requirements of the project. A certificate of compliance shall include, but not be limited to the project title, delivery location, date (or approximate date) of delivery, name of the material with appropriate classification or model numbers, quantity, name of the manufacturers, statement of compliance with all requirements of the Technical Provisions, and the name, title and signature of the certifying agent.

#### **1.05 REFERENCE STANDARDS**

- A. Referenced standards shall be the most recent version or edition.
- B. American Society for Testing and Materials (ASTM)
- C. ASTM F480 Standard Specification for Thermoplastic Well Casing Pipe and Couplings Made in Standard Dimension Ratios, SCH 40 and SCH 80 American Petroleum Institute (API)
  - 1. "Std. 13-A for Drilling Fluid Materials"
  - 2. Std. 13-B1, Recommended Practice for Field Testing Water-Based Drilling Fluids
- D. California Department of Water Resources Well Standards
  - 1. Bulletin 74-81/Supplement 74-90 or latest applicable edition/revision

#### **1.06 PERMITS**

- A. The Contractor shall be responsible for obtaining all necessary permits to perform the borehole drilling and monitoring well installation.
- B. The well permitting agency is:
  - Contra Costa County Environmental Health Division
  - 2120 Diamond Boulevard, Suite 100
  - Concord, CA 94520
  - Phone: 925-608-5500
  - Fax: 925-608-5502
- C. The Contractor shall notify the District, and the appropriate regulatory and permitting agencies in advance of the commencement work, inspection items, and project milestones.
- D. All drilling and well construction activities shall comply with local and State standards.

## **PART 2      PRODUCTS**

### **2.01    MATERIALS**

#### **A.      SEALING MATERIAL**

1.      Sealing material, consisting of sand-cement grout shall be employed for abandonment purposes and surface seals in the wells. Bentonite chips as well as sand/cement grout may be employed in the wells for intermediate seals and to limit infiltration of cement grout into the gravel envelope.
2.      The sealing material shall be composed of a slurry of sand-cement grout. The grout shall consist of a sand-cement mixture in accordance with California Department of Water Resources Well Standards, Bulletin 74-81/Supplement 74-90.
3.      The mixture for the surface, or sanitary, seal shall conform to State standards and local ordinances for annular seals.
4.      The bentonite sealing material shall be a graded chip bentonite with granules ranging from 1/4 inch to 3/8 inch. An approved product for the bentonite seals is "HOLEPLUG" as manufactured by the NL Baroid Division of NL Industries, Inc.

#### **B.      WELL CASING AND SCREEN MATERIAL**

1.      The 2.5-inch diameter PVC well casing and well screen for the monitoring well will be made of ASTM F-480-88A Schedule 80 PVC. The ends of each joint shall be threaded and couple with O-ring seals. The blank casing will be 2.5-inch Schedule 80 PVC, ASTM F480-88a. The well screen shall be fabricated from the same material as the blank casing. The perforations shall be machine cut horizontal slots, with openings of 0.030 inch.
2.      The bottom of each PVC casing assembly shall be furnished with PVC threaded, pointed or rounded end cap of the same schedule and size as the casing and the same specifications as described herein.
3.      Each casing, with the exception of those monitoring wells constructed with an auger flight, will be fitted with appropriate centralizers to ensure that the well casings meet the minimum 2-inch separation distance from the borehole wall.
4.      The top of each casing shall be furnished with a watertight and locking security plug.

C. GRAVEL ENVELOPE

1. Gravel pack material shall be of the 8x16 gradation or equivalent as determined by the District. Gravel pack material shall be hard, water-worn, rounded, and washed clean of silt, fine sand, dirt, and foreign matter (crushed gravel will not be accepted). The gravel, if stockpiled at the well site, shall be protected and kept free of foreign matter.

**PART 3 EXECUTION**

**3.01 TEST HOLE DRILLING AND MONITORING WELL CONSTRUCTION**

- A. Two methods of drilling are approved:
  - a. Direct Mud Rotary Drilling – For test holes that will be drilled to a depth greater than 100-feet shall be drilled using the direct mud rotary drilling method.
  - b. Hollow Stem Auger Drilling – For test holes that will be drilled to a depth less than 100-feet shall be drilled using the hollow stem auger drilling method.
- B. All drilling units shall be in good condition and of sufficient capacity to perform the specified drilling and well construction.
- C. Drilling oversight shall be provided by individuals experienced in the drilling, design, and construction of monitoring wells with intermediate bentonite seals.. Drill cuttings and geophysical surveys shall be evaluated by a licensed Professional Geologist (PG) or someone working under the direct supervision of a PG.

**3.02 DIRECT MUD ROTARY DRILLING**

- A. TEST HOLE DRILLING
  1. The test holes shall be drilled using the direct rotary method. The hole shall be drilled at a minimum diameter of 8 3/4 inches. The final depth of each test hole will depend on the location and the lithology encountered while drilling and will be determined by the District. The maximum anticipated test hole depth is 300 feet.
  2. The test holes shall be drilled using the direct rotary drilling method of construction. The drilling fluid for the direct rotary drilling operation shall conform to the specifications of Section 3.02 B.
  3. The drilling operations shall be conducted using equipment that is adequate to reach the depth and perform the evaluations specified in the Technical Provisions.

4. The Contractor shall take all measures necessary to protect the top portions of the test hole from caving or raveling.
5. The Contractor shall keep records providing the following information:
  - a. A record of construction activities for each shift.
  - b. A time drilling log of the test hole recording the time (in minutes) required to drill down each section of drill pipe.
  - c. A log of drilling bit types and depths of changes.
  - d. Record of drilling fluid properties at 4-hour intervals during drilling operations. The record shall show drilling fluid weights, Marsh Funnel viscosity, sand content, drilling fluid losses, and any additives used.
  - e. A drilling log which defines and classifies the type of formations encountered during the drilling. The log will consist of the depth at which each change in formation is encountered, the classification of the material encountered, its color and particle size. Classification of silt, sand, gravel, cobbles, etc. shall be based on the size of material encountered in accordance with the established and accepted geologic standard for classification of these materials. If more than one size of material is encountered in a formation such as "sand and clay", an estimate of the quantity of each shall be recorded, such as "20% sand, 80% clay".
  - f. All measurements for depths shall be referenced to the existing ground surface at the well site.
  - g. Installation of water level measurement equipment.
6. During the drilling of the test holes, the Contractor shall collect representative samples of the rotary drill cuttings at 10-foot intervals and at formation changes. The samples collected shall not be washed. They shall be carefully drained of excess drilling fluid but in a manner which will preserve the finer particle size of the sample. Each sample taken shall be preserved in quart-size "Zip-Lock" plastic freezer bags and marked as to date, depth, and well number. The samples shall be properly stored by the Contractor in a manner as to prevent breakage or loss until they are accepted by the District.
7. Upon completion of the test hole drilling, a geophysical log shall be conducted.

## B. DRILLING FLUID CONTROL PROGRAM

1. A drilling fluid control program shall be prepared by a qualified, professional drilling fluids engineer and submitted to the District for approval. The Contractor shall be responsible for maintaining the quality of the drilling fluid to assure protection of water bearing and potential water bearing formations exposed in the borehole, and the ability to obtain reliable representative samples of the formation materials.
2. Material used by the Contractor to prepare the drilling fluid shall be composed of water from an assigned source and drilling additives processed to meet or surpass the specification in the American Petroleum Institute "Std. 13-A for Drilling Fluid Materials". All drilling fluid additives will comply with recognized industry standards and practices, and they shall be used as prescribed by the manufacturer. Toxic and/or dangerous substances shall not be added to the drilling fluid.
3. Proper control of the drilling fluid must be maintained to the satisfaction of the District. The Contractor will be required, at the Contractor's expense, to retain or employ an experienced, qualified drilling fluid, or mud, engineer to supervise and maintain drilling fluid characteristics to the satisfaction of the District if such control cannot be accomplished by the Contractor.

## C. GEOPHYSICAL LOGGING

1. The Contractor shall furnish services for logging the test holes. Acceptable geophysical logging service companies include Pacific Surveys, Stewart Logging Services, or others approved by the District. Borehole geophysical logs, consisting of gamma ray, spontaneous potential (SP) and multiple resistivity, shall be conducted in each test hole.
2. Upon completion of logging operation, the Contractor will deliver four (4) field prints to the District. Four final prints and an electronic ASCII file of the geophysical surveys shall be provided with the final records submittal. The field copies of the electrical log shall be approved by the District before the logging service is released from the site by the Contractor.

## D. TEST HOLE REAMING

1. Test holes exceeding 100-feet in depth shall be drilled using the direct mud rotary method. Drilling fluid properties must conform to those specified in Section 3.02 B.
2. The test holes shall be reamed to a minimum diameter and depth as specified in the design. The Contractor shall be responsible to protect the pilot hole from caving. The Contractor shall exercise caution to ensure that the hole remains straight and plumb during the reaming operations.

#### E. WELL CASING AND SCREEN INSTALLATION

1. A wiper trip shall be conducted to ensure that the borehole is open to the total depth prior to running casing.
2. A tremie pipe of a minimum two-inch diameter shall be run into the borehole to the total depth of the casing installation. Circulation by pumping shall be established using fluid from the drilling fluid/mud tank of the same viscosity as that in the borehole. Circulation shall continue for a period of thirty minutes prior to casing installation.
3. With the tremie pipe remaining in the borehole, casing installation shall proceed in accordance with the final, approved well design for casing installation.
4. The casing assemblies shall be installed to the specified depth supported above the ground surface. The casing shall be capped to ensure that foreign particles are prevented from entering the casing.
5. The casing shall be suspended in tension from the surface by means of an appropriate hanger or clamp. The bottom of the casing shall be at a sufficient distance above the bottom of the reamed hole to ensure that none of the casing will be supported from the bottom of the hole.
6. Circulation through the tremie pipe shall continue during the casing installation.
7. If, for any reason, the casing cannot be landed in the correct position or at a depth acceptable to the Engineer, the Contractor shall remove the casing, recondition the borehole and reinstall the casing to the specified depth. If the casing cannot be removed from the borehole the contractor shall construct another well immediately adjacent to the original location and complete the well in accordance with these Technical Provisions at no additional cost to the Owner. The abandoned hole shall be sealed in accordance with these Technical Provisions and in accordance with any laws pertaining to proper well abandonment.
8. If any of the casing assemblies collapse prior to well completion, the remaining hole shall be abandoned in accordance with these Technical Provisions. A replacement borehole and well shall be drilled and constructed at an adjacent location as directed by the Engineer.

#### F. GRAVEL ENVELOPE AND INTERMEDIATE SEALS

1. Intermediate bentonite seals may be used in saturated zones. Sand/cement grout shall be used for intermediate seals in unsaturated zones.



2. Prior to placement of the gravel pack and intermediate seals in the well, the drilling fluid shall be thinned with clean water. Thinning shall be accomplished by reducing the viscosity of the drilling fluid in the sump to a maximum marsh funnel viscosity of 30 seconds and a maximum weight of 8.9 pounds per gallon by the addition of clean water to the sump. The Contractor shall avoid the direct injection of water into the well bore through the tremie pipe in order to prevent unbalancing the fluid consistency in the borehole.
3. Gravel packing and sealing material shall be pumped or gravity fed through the tremie pipe. The gravel pumping system shall consist of a hopper, which will allow for the calculation of the amount of gravel packing material entering the borehole.
4. The tremie pipe shall be removed in approximately twenty-foot intervals when the gravel in the borehole reaches the tremie pipe.
5. The quantities of gravel placed in the annulus of each well shall not be less than the computed volume of the annulus. A quantity less than the computed value will be judged as an indication of voids, and corrective measures shall be taken by the Contractor.
6. If the volume of gravel installed in the annulus is less than the theoretical volume, the well may be rejected by the District.
7. Gravel packing and bentonite seal placement shall continue uninterrupted until the gravel pack reaches the depth of the surface seal.

G. ANNULAR SEAL

1. Installation of the annular seal shall conform to State Water Well Standards and the requirements of the well permitting agency.
2. The Contractor shall proceed with sealing operations after the District verifies the depth of the top of the gravel in the well annulus.
3. The tremie pipe shall be installed no more than 5 feet above the placed gravel envelope before beginning seal placement. The bottom of the tremie pipe shall remain submerged in the sealing material maintaining a positive displacement throughout the sealing process until the grouting material has reached the ground surface.
4. The Contractor shall take measures to ensure that the weight of the cement column does not collapse the well casing during the sealing operation.
5. Well development shall not commence until a minimum of 24 hours after placement of the seal.

### **3.03 HOLLOW STEM AUGER DRILLING**

#### **A. TEST HOLE DRILLING**

1. The test holes shall be drilled using the hollow stem auger method. The diameter of the borehole shall be a minimum of 10-inches. The final depth of the test hole will depend on location and the lithology encountered while drilling and will be determined by the District. The maximum anticipated test hole depth is 100 feet.
2. The drilling operations shall be conducted using equipment that is adequate to reach the depth and perform the evaluations specified in the Technical Provisions.
3. The Contractor shall keep records providing the following information:
  - a. A record of construction activities for each shift.
  - b. All measurements for depths shall be referenced to the existing ground surface at the well site.
4. During the drilling of the test hole, the Contractor shall collect continuous core samples using the split barrel sample collection procedure as outlined in ASTM D1586-11L: Standard Test Method for Standard Penetration Test (SPT) and Split-Barrel Sampling of Soils. The Contractor shall deliver samples to the District.

#### **B. WELL CASING AND SCREEN INSTALLATION**

1. With the drilling string still in the borehole, the casing assembly shall be installed within the inside of the drill pipe in accordance with the final well design for casing installation. Care shall be taken to ensure that the casing is centered within the drill pipe.
2. The casing assembly shall be installed to the specified depth supported above the ground surface. The casing shall be capped to ensure that foreign particles are prevented from entering the casing.

#### **C. GRAVEL ENVELOPE AND TRANSITION SAND SEALS**

1. The gravel will be placed in the annulus between casing assembly and the inside of the drill string and brought up to a level within the annulus so that when a drill flight is removed sand will fill the annulus between the casing and the drill string. Sufficient sand will be placed inside the drill string so that sand will remain in the drill string when a flight is removed. This procedure will be repeated until the gravel envelope is to the level specified in the final well design for casing installation.

2. The fine sand transition seal will be placed in the annulus between the casing assembly and the inside of the drill string and brought up to a level within the annulus so that when a drill flight is removed sand will still fill the annulus between the casing and the drill string. This procedure will be repeated until the transition seal is to the level specified in the final well design for casing installation.
3. The quantities of gravel placed in the annulus of each well shall not be less than the computed volume of the annulus. A quantity less than the computed value will be judged as an indication of voids, and corrective measures shall be taken by the Contractor.
4. If the volume of gravel installed in the annulus is less than the theoretical volume, the well may be rejected by the District.
5. Gravel packing and transition seal placement shall continue uninterrupted until the gravel pack reaches the depth of the surface seal.

**D. ANNULAR SEAL**

1. The annular seal sealing material will be poured from the surface into the annulus from the top of the fine sand transition seal to 12-inches from the finish grade if the seal depth is less than 20 feet below ground surface and no water is present in the borehole. If the top of the fine sand transition seal is more than 20 feet below ground surface, or if there is water in the borehole, the sealing material will be placed using the tremie pipe method.
2. Sealing operations shall continue uninterrupted until the seal is installed to the specified depth.

**3.04 WELL DEVELOPMENT**

- A. The Contractor shall provide an air compressor, sufficient pipe, and necessary equipment used for pumping that shall be capable of pumping 25 gpm from a static water level of 100 feet during development.
- B. The air compressor used during well development shall be fitted with in-line filters to prevent volatile organic compounds from entering the well casings from the compressor. A 0.3-micron pre-filter and a 0.01-micron filter run in series and verified compatible to the Contractor's compressor will be required during all phases of well development.
- C. After the placement of the gravel envelope and annular seals has been completed, the gravel envelope shall be cleaned of all fluids, cake, and substances that would impair the flow of water into the well and the quality thereof. Cleaning shall be accomplished by airlift pumping and surging until the gravel has been cleaned and consolidated.

- D. Pumping will be done with a minimum 3/8-inch diameter air pipe using the well casing as the eductor pipe. The pumping operations will be conducted until the well is fully developed and discharging clean ground water.
- E. The development shall continue until the well produces water free of sand and the following turbidity guidelines can be achieved after surging the well. For piezometers that produce less than 2 gpm, a turbidity of 10 NTU within two casing volumes of purging. For piezometers that produce at least 2 gpm, a turbidity of 5 NTU must be achieved within two casing volumes of purging.

### **3.05 SURFACE COMPLETION**

#### **A. FLUSH MOUNT SURFACE COMPLETIONS**

- 1. All below ground (flush mount) well completions will be housed in a traffic rated valve box with a cast iron lid and locking ring. The valve box will be a Morrison Series 519 manhole or approved equal.
- 2. The Contractor shall excavate a hole large enough to allow for a 4-inch apron of concrete around the manhole at ground surface to a depth of 16-inches to allow for the installation of the specified manhole.
- 3. The box will be centered over the well casing and set flush with existing grade.
- 4. A concrete slurry shall then be poured and tamped on top of the annular seal and brought to grade level such that the box is set in concrete.

### **3.06 BOREHOLE ABANDONMENT**

- A. At the District's determination, following completion of geophysical logging operations, a borehole, or a lower portion of a borehole, shall be destroyed in accordance with State and local standards for the construction and destruction of wells and other deep excavations.
- B. Sand/cement grout shall be injected from the bottom of the borehole by means of pumping equipment and a tremie pipe. The tremie pipe may be raised as the grout is placed but the discharge end must be always submerged in grout until the grouting is completed.

### **3.07 REJECTED BOREHOLE OR WELL**

#### **A. GENERAL**

- 1. The District will not accept any borehole or well when such a hole fails to reach the specified or directed final depth and/or diameter for any preventable cause, or when such a test hole fails to meet these Technical Provisions. Such holes will be rejected and shall be replaced as specified herein. Preventable failures include any failure caused by faulty or inadequate drilling equipment, failure caused by negligence or improper

drilling operations or techniques, failure caused by the installation of faulty or non-approved materials, or failure caused by improperly protecting drill holes and drilling work from the natural elements, including cave-ins resulting from existing soil conditions.

**B. SEALING AND REPLACEMENT OF A REJECTED BOREHOLE OR WELL**

1. Any rejected borehole or well shall be sealed at no additional cost to the District. Any casing remaining in the hole shall be cut off at a depth of five feet and the upper portion thereof removed.

**C. REPLACEMENT OF A REJECTED BOREHOLE OR WELL**

1. Any rejected borehole or well shall be replaced by another hole adjacent to the first, or at a location as directed by the District.

**3.08 SITE CLEANUP AND RESTORATION**

- A. The Contractor shall keep the premises free from accumulations of waste materials, rubbish, and other debris resulting from the Work, and at completion of the Work, they shall remove all waste materials, rubbish, and debris from and about the well site as well as all tools, construction equipment, fuel tanks, machinery, and surplus materials.
- B. The Contractor shall leave the site clean and ready for use by the District. The Contractor shall restore to their original condition all temporary work areas. Drill cuttings are to be properly disposed of offsite by the Contractor in accordance with these Technical Provisions.
- C. The Contractor is responsible for any damages to properties adjacent to the sites caused by drilling or construction activities associated with the Work described herein.

**3.09 RECORDS**

- A. Prior to final acceptance of a test hole or well, the Contractor shall prepare and deliver to the District a Driller's Report in the format required by the State of California.
- B. The Contractor shall prepare two (2) final prints of the daily tour reports, the drilling logs, and as-built construction drawings.

**PART 4 WATER LEVEL MONITORING EQUIPMENT**

**4.01 GENERAL**

- A. The Contractor shall purchase and install automated water level measuring equipment (transducers) in each monitoring well.

- B. Transducers shall be connected to telemetry equipment installed at each monitoring well site capable of transmitting water level data via a cellular system to a cloud-based application accessible to the District.
- C. Transducers shall be located in the screened interval of each monitoring well.
- D. Contractor shall install, setup, ensure, and demonstrate to the satisfaction of the District proper operation of all installed equipment

#### **4.02 EQUIPMENT**

- A. Transducers: Level TROLL 400 Data Logger manufactured by In-Situ
- B. Telemetry: VuLink data logger and telemetry unit manufactured by In-Situ
- C. Antenna: Vulink 4G/LTE/Cellular Antenna
- D. Communication Cable: Non vented, twist lock cable compatible with Level Troll and Vulink equipment
- E. Miscellaneous: Connectors, hangers, caps, fittings, and other materials necessary for equipment installation and operation.

#### **4.03 INSTALLATION**

- A. Transducers: Transducers shall be deployed in the monitoring well screen interval. The pressure rating of transducers shall be sufficient enough to accommodate the column of water equal to the deployment depth and the highest anticipated water levels. Transducers shall be connected to the telemetry units using communications cable. Communications cable lengths shall be sized for each monitoring well.
- B. Telemetry Unit: Telemetry units shall be installed in the monitoring well casing. Telemetry assemblies (transducer, cable, and telemetry unit shall be secondary secured at the surface.
- C. Antennas: If cellular connectivity allows, antennas shall be installed within the surface completion. In areas of poor cellular connectivity, antennas will be affixed to the outside of the manhole lid utilizing an appropriate epoxy material to secure the antenna and connecting wire.

#### **4.04 TESTING**

- A. Contractor shall test for proper operation of water level measuring and telemetry equipment and communications to VuLink's cloud-based data management application.

#### **4.05 RECORDS**

- A. Contractor shall provide District with installation notes, model and serial numbers of all installed equipment, and transducer deployment depths for each monitoring well.

END OF SECTION

## SECTION 02610

### DUCTILE IRON PIPE AND FITTINGS

#### PART 1 GENERAL

##### 1.01 SCOPE OF WORK

- A. Furnish all labor, materials, equipment and incidentals required, install, test, and disinfect ductile iron pipe and fittings. Provide thrust blocks and couplings as required to achieve a complete pipe system.
- B. Where the word "pipe" is used, it shall refer to pipe, fittings, or appurtenances unless otherwise noted.

##### 1.02 SUBMITTALS

- A. Submit, shop drawings and product data required to establish compliance with the Section. Submittals shall include the following
  - 1. Prior to shipment of pipe, submit a certified affidavit of compliance from the pipe manufacturer stating that the pipe, fittings, gaskets, linings and exterior coatings for this project have been manufactured and tested in accordance with AWWA and ASTM standards and requirements specified herein.

##### 1.03 REFERENCE STANDARDS

- A. Referenced standards shall be the most recent version or edition.
- B. American Society for Testing and Materials (ASTM)
  - 1. ASTM A377 – Standard Index for Specifications for Ductile-Iron Pressure Pipe
  - 2. ASTM C150 – Standard Specification for Portland Cement
  - 3. ASTM F593 – Standard Specification for Stainless Steel Bolts, Hex Cap Screws, and Studs
- C. American National Standards Institute (ANSI)
  - 1. ANSI B1.1 – Unified Inch Screw Threads, (UN and UNR Thread Form)
  - 2. ANSI B16.1 – Cast Iron Pipe Flanges and Flanged Fittings Classes 25, 125 and 250
  - 3. ANSI B18.2 – Square and Hex Bolts and Screws Inch Series Including Hex Cap Screws and Lag Screws



- D. American Water Works Association (AWWA)
1. AWWA C104 – Cement-Mortar Lining for Ductile-Iron Pipe and Fittings
  2. AWWA C105 – Polyethylene Encasement for Ductile-Iron Pipe Systems
  3. AWWA C110 – Ductile-Iron and Gray-Iron Fittings
  4. AWWA C111 – Rubber-Gasket Joints for Ductile-Iron Pressure Pipe and Fittings
  5. AWWA C115 – Flanged Ductile-Iron Pipe with Ductile-Iron or Gray-Iron Threaded Flanges
  6. AWWA C150 – Thickness Design of Ductile-Iron Pipe
  7. AWWA C151 – Ductile-Iron Pipe, Centrifugally Cast
  8. AWWA C153 – Ductile-Iron Compact Fittings
  9. AWWA C600 – Installation of Ductile-Iron Water Mains and Their Appurtenances
  10. AWWA C606 – Grooved and Shouldered Joints
  11. AWWA C651 – Disinfecting Water Mains

#### **1.04 QUALITY ASSURANCE**

- A. Each length of ductile iron pipe supplied for the project shall be hydrostatically tested at the point of manufacture to 500 psi for a duration of 10 seconds per AWWA C151. Testing may be performed prior to machining bell and spigot. Failure of ductile iron pipe shall be defined as any rupture of the pipe wall. Certified test results shall be furnished in duplicate to the District prior to time of shipment.
- B. All ductile-iron pipe and fittings to be installed under this project shall be inspected and tested at the foundry as required by the standard specifications to which the material is manufactured. Furnish in duplicate to the District sworn certificates of such tests and their results prior to the shipment of the pipe.
- C. All pipe and fittings to be installed under this Contract may be inspected at the plant for compliance with this Section by an independent testing laboratory selected by the District, at the District's expense.
- D. Inspection of the pipe and fittings will also be made by the District or representative of the District after delivery. The pipe shall be subject to rejection at any time on account of failure to meet any of the specified requirements, even though sample pipes may have been accepted as satisfactory at the place of manufacture. Pipe rejected after delivery shall be marked for identification and shall be removed from the job.

- E. All pipe and fittings shall be permanently marked with the following information:
  - 1. Manufacturer, date.
  - 2. Size, type, class, or wall thickness.
  - 3. Standard produced to (AWWA, ASTM, etc).

## **PART 2 PRODUCTS**

### **2.01 MATERIALS**

- A. Pipe
  - 1. Pipe shall be supplied in standard factory lengths for all pipe diameters.
  - 2. Bell and spigot ductile iron pipe shall be Pressure Class 250, or greater, as per AWWA C150.
  - 3. Flanged ductile iron pipe shall conform to AWWA C115 and C110. Four (4) inch flanged pipe shall be Thickness Class 51 as per AWWA C150, and flanged pipe sizes 6 through 24 inches shall be Thickness Class 50 as per AWWA C150.
  - 4. Ductile iron pipe shall be as manufactured by U.S. Pipe Company, Inc.; American Cast Iron Pipe Company; Flow Water System Company, Pacific States, or equal.
- B. Joints
  - 1. Ductile iron pipe shall have push-on, mechanical, locking, or flanged joints. Flange shall be flat face type, unless otherwise noted, meeting ANSI requirements, minimum Class 250.
  - 2. Flange gasket shall be full face type per AWWA C111 to provide multi-swell sealing for the flanged ductile iron joints. Gaskets shall be Garlock 3760-U only, no equal.
  - 3. Flange assembly bolts shall be ASTM F593, 304 stainless steel, hex-head bolts, washers, and hexagon nuts. Bolts shall have "F-593C" or "F-593D" stamped on the head. Threads shall conform to ANSI B1.1. Bolt length shall be such that after joints are assembled, the bolts shall protrude through the nuts, but not more than ½ inch.
  - 4. Sleeve type couplings shall be Dresser Style 38 or 138 as manufactured by Dresser Industries or equal, with EPDM gaskets.
  - 5. Flanged coupling adaptors shall be Smith-Blair Type 913 or equal, with EPDM gaskets.

6. Where restrained joints are specified on the plans, locking joints shall be Field Lok 350 by U.S. Pipe.
- C. Fittings
1. Pipe fittings shall be ductile iron with a pressure rating of 250 psi. Fittings shall meet the requirements of AWWA C110 or AWWA C153 as applicable. Fittings shall have the same pressure rating, as a minimum, of the connecting pipe. Fittings shall be manufactured by Tyler, Sigma or Star.
- D. Interior Lining
1. Ductile iron pipe and fittings shall have a cement mortar lining and asphaltic seal coat in accordance with AWWA C104.
- E. Exterior Coatings
1. Unless otherwise specified, all coatings shall be shop applied with "hold-backs" provided as required at pipe and fitting ends for satisfactory installation for joint connections in the field. Provide all necessary coating materials to perform field coating applications at joints. Unless otherwise noted, field applied coating material shall be compatible with or equal to the shop applied material. Field repair of pipe with damaged coating shall receive prior approval of the District. If, in the opinion of the District that the coating damage is beyond repair the pipe shall be replaced. All flange bearing surfaces shall be uncoated.
- F. All pipe shall be cathodically protected per Section 16640.

## **PART 3 EXECUTION**

### **3.01 PIPE INSTALLATION**

- A. General
1. All piping and fittings shall be installed true to alignment. Thrust blocks or other anchorage shall be provided where required. Any damage to linings shall be repaired to the satisfaction of the District before the pipe is installed. Each length of pipe shall be cleaned out before installation. All of manufacturer's recommendations shall be complied with.
  2. The deflection at joints shall not exceed the values stipulated in AWWA C600, unless specially designed bells and spigots are provided. Fittings, in addition to those shown on the Drawings, shall be provided, if required, in areas where conflict exists with the existing facilities.
  3. When pipe cutting is acceptable to the District, the cutting shall be done by abrasive saw, leaving a smooth cut at right angles to the axis of the pipe. After cutting, the end of pipe shall be dressed with a file or power grinder to remove all roughness and sharp edges. Bevel the cut end per

manufacturer recommendations to ensure a smooth insertion into fittings and bell ends. Any damage to the lining shall be repaired to the satisfaction of the District per manufacturer specifications.

4. Ductile iron and fittings shall be installed in accordance with requirements of AWWA C600 modified.

**B. Jointing**

1. Flanged joints shall be made using gaskets, bolts, bolt studs with a nut on each end, or studs with nuts where the flange is tapped. The number and size of bolts shall conform to the same ANSI Standard as the flanges.
2. Mechanical joints shall be carefully assembled in accordance with the manufacturer's recommendations. If effective sealing is not obtained, the joint shall be disassembled, thoroughly cleaned, and reassembled. Bolts in flanged joints or mechanical joints shall be tightened alternately and evenly to torque values listed in Appendix A of ANSI/AWWA C111. Overtightening of bolts to compensate for poor installation practice will not be permitted.
3. Sleeve type couplings and grooved joints using split ring couplings shall be installed in accordance with the procedures recommended by their respective manufacturers.
4. For the installation of push-on joints, the pipe manufacturer's instructions and recommendations for proper jointing operations shall be followed. Brush both the gasket and plain end with soapy water or an approved push-on joint lubricant meeting the requirements of ANSI/AWWA C111/A21.11. The lubricant shall be stored in closed containers and shall be kept clean. Each spigot end shall be suitably beveled to facilitate assembly.
5. All connections between ductile iron and steel pipe shall be electrically separated by an insulated flange or insulated mechanical coupling.
6. All pipe and appurtenances connected to equipment shall be supported in such a manner as to prevent any strain being imposed on the equipment. When manufacturers have indicated requirements that piping loads shall not be transmitted to their equipment, submit a certification stating that such requirements have been complied with.

**3.02 CLEANING, TESTING, AND DISINFECTION**

- A. Testing and disinfection of all ductile iron pipe shall be per Section 02675.

END OF SECTION

## SECTION 02620

### POLYVINYL CHLORIDE (PVC) PIPE AND FITTINGS

#### **PART 1 GENERAL**

##### **1.01 SCOPE OF WORK**

- A. The Contractor shall furnish all labor, supervision, materials, tools, equipment and incidentals required and install and test polyvinyl chloride (PVC) potable and recycled water, fittings, appurtenances and adapters as shown on the Drawings and as specified herein.

##### **1.02 SUBMITTALS**

- A. The Contractor shall submit shop drawings, product data and design calculations for District's review.
- B. Shop drawings shall show layout and details of reinforcement, jointing, specials and fittings, connection to structures, method of manufacture and installation of pipe, material list of hardware to assemble pipe, and a schedule of pipe lengths (including the length of individual pipes by diameter) for the entire job.
- C. Design calculations for the conditions specified in Paragraph 2.01 of this Section, shall be submitted with the shop drawings and shall include all formulas used in the calculations, all values of constants used in the formulas in accordance with ANSI/AWWA and ASTM reference standards.
- D. Prior to shipment of pipe, the Contractor shall submit a certified affidavit of compliance from the manufacturer stating that the pipe, fittings, gaskets, coatings for this project have been manufactured and tested in accordance with ANSI/AWWA and ASTM standards and requirements specified herein.
- E. Manufacturer's recommendations for handling, storing and installation of pipe and fittings.

##### **1.03 REFERENCE STANDARDS**

- A. Referenced standards shall be the most recent version or edition.
- B. American Society for Testing and Materials (ASTM)
  - 1. ASTM D1784 – Standard Specification for Rigid Poly (Vinyl Chloride) (PVC) Compounds and Chlorinated Poly (Vinyl Chloride) (CPVC) Compounds
  - 2. ASTM D3139 – Standard Specification for Joints for Plastic Pressure Pipes Using Flexible Elastomeric Seals
  - 3. ASTM F477 – Standard Specification for Elastomeric Seals (Gaskets) for Joining Plastic Pipe

- C. American Water Works Association (AWWA)
  - 1. AWWA C110 – Ductile-Iron and Gray-Iron Fittings
  - 2. AWWA C111 – Rubber-Gasket Joints for Ductile-Iron Pressure Pipe and Fittings
  - 3. AWWA C153 – Ductile-Iron Compact Fittings
  - 4. AWWA C605 – Underground Installation of Polyvinyl Chloride (PVC) Pressure Pipe and Fittings for Water
  - 5. AWWA C900 – Polyvinyl Chloride (PVC) Pressure Pipe and Fabricated Fittings, 4 In. Through 60 In. (100 mm Through 1,500 mm)
  - 6. AWWA Manual No. 23 – PVC Pipe - Design and Installation
- D. National Sanitation Foundation (NSF)
  - 1. Standard No. 14 – Plastic Piping Components and Related Materials
  - 2. Standard No. 61 – Drinking Water System Components - Health Effects

#### **1.04 QUALITY ASSURANCE**

- A. All PVC pipe and ductile iron fittings shall be from single manufacturers. The supplier shall be responsible for the provisions of all test requirements specified in the referenced ASTM, AWWA and NSF Standards for the type of pipe used. The Contractor shall furnish the District certification of such tests and their results prior to the shipment of the pipe.
- B. All pipe and fittings to be installed may be inspected at the plant for compliance with this Section by an independent testing laboratory provided by the District. The Contractor shall require the manufacturer's cooperation in these inspections. The pipe manufacturer shall be required to:
  - 1. Have sufficient pipe made in advance so that a reasonable amount will be available at each plant inspection.
- C. Inspection of the pipe and fittings will also be made by the District or other representatives of the District after delivery. The pipe shall be subject to rejection at any time on account of failure to meet any of the Specification requirements, even though sample pipes may have been accepted as satisfactory at the place of manufacture. Pipe rejected after delivery shall be marked for identification and shall be immediately removed from the job.

- D. Any PVC pipe showing evidence of UV degradation through discoloration will be rejected.
- E. The following shall be continuously indent printed on the pipe or spaced at intervals not exceeding 5 feet:
  - 1. Name and/or trademark of the pipe manufacturer.
  - 2. Nominal pipe size.
  - 3. Dimension ratio.
  - 4. The letters PVC followed type of pipe.
  - 5. Manufacturing standard reference, e.g., ASTM F679, or ASTM F789.
  - 6. A production code from which the date and place of manufacture can be determined.

## **PART 2 PRODUCTS**

### **2.01 DESIGN**

- A. The internal diameter of the pipe shall meet the stated internal diameter as shown on the Drawings.
- B. Design for the net thickness for external loading shall be taken as the greater of the following conditions:
  - 1. 3 feet of cover with AASHTO HS-20 wheel loads for two trucks passing with an impact factor of 1.5.
  - 2. Depth from existing ground level or future proposed grade (whichever is greater) to top of pipe as shown on Drawings, with AASHTO HS-20 wheel loads for two trucks passing with an impact factor of 1.5.
  - 3. Soil Density: 120 pounds per cubic foot.
  - 4. Deflection lag factor: 1.00
  - 5. Soil Modulus (E'): 1,500 psi

### **2.02 PVC PIPE AND FITTINGS FOR POTABLE WATER SERVICE**

- A. The pipe shall be PVC 1120 made from PVC compounds Class 12454-A or 12454-B as defined in ASTM D1784. Each pipe length shall be marked with the manufacturer's name or trademark, size, material code, pressure class, AWWA designation number and seal of test agency that verified pipe material for potable-water service.

- B. PVC pressure pipe sized 4 through 12 inches shall conform to the requirements of AWWA C900. All piping shall be minimum Pressure Class 150 with a wall thickness equal or greater to that corresponding to a Dimension Ratio (DR) of 18.
- C. Pipe with increased wall thickness shall be used in areas required by the State Water Resources Control Board, Division of Drinking Water, for water mains paralleling and crossing sanitary sewers or when the depth of the main does not meet minimum requirements. Pipe identified as Pressure Class 200 pipe shall have a wall thickness equal or greater to that corresponding to a DR of 14.
- D. PVC pipe and associated fittings shall have bell and spigot push-on joints. Solvent welded joints will not be allowed. The bell shall consist of an integral wall section with a solid cross-section elastomeric gasket securely locked in place to prevent displacement during assembly. The performance of the elastomeric gasketed joint shall conform to ASTM D3139 and ASTM F477. All pipe shall have a "home" mark on the spigot end to indicate proper penetration when the joint is made.
- E. Potable water PVC pipelines shall be blue in color.
- F. All fittings and accessories for waterlines shall be ductile iron and shall conform to the requirements of AWWA C110 or AWWA C153 minimum Class 250. Fittings shall be push on, flanged, or mechanical joint and shall be lined and coated for potable water service.
  - 1. Gaskets for push-on type joints shall be synthetic rubber and conform to AWWA C111.
  - 2. Mechanical joint fittings shall not be used with PVC pipe unless prior approval is received from the District. Mechanical joint fittings shall incorporate a Megalug restraint system, or other approved restraint system. Mechanical joint fittings shall be bitumastic lined and coated.
  - 3. Mechanical couplings, where shown on the drawings, shall be long barrel type, Style 253 by Dresser Industries, or equal. Middle ring shall be a thickness equal to or greater than the thickness of the pipe wall. Couplings shall have EPDM gaskets, and shall be shop-coated with fusion bonded powder epoxy coating meeting requirements of NSF-61. The shop-coat shall be compatible with the final exterior coating system. Couplings shall be furnished complete. All sleeve couplings shall be harnessed unless otherwise noted. All nuts, bolts, and threaded rods shall be 304 stainless steel.
- G. Potable water pipelines shall be by Vinyl Tech, Royal Group, or Northern. The standard length of pipe shall be 20 feet for all pipe diameters.
- H. Ductile iron fittings shall be by Sigma, Tyler, or Star.
- I. Fusible water pipelines shall be supplied in cast iron outside diameters (CIOD) by Aegion, or equal.



## **2.03 PVC PIPE AND FITTINGS FOR RECYCLED WATER SERVICE**

- A. PVC pipe for recycled water shall be the same as PVC pipe for potable water as indicated in Section 02620 2.02, and as modified by this section.
- B. Recycled water piping shall be clearly marked "RECYCLED WATER" or equivalent. Recycled water pipe shall be purple in color.
- C. Fire Hydrants installed on recycled water systems shall be painted purple in color in conformance with the requirements listed in Section 15100 Valves and Hydrants and Appurtenances.

## **2.04 COPPER WIRE AND WARNING TAPE**

- A. All nonmetallic water mains shall include a continuous 12 gage, single-strand copper wire with blue insulation, taped to the top of the pipe and extended upwards into all valve boxes.
- B. Plastic warning tape shall be installed over all water lines as shown on Standard Drawing DWD 1. Warning tape shall be blue, minimum 6 inches wide, and printed continuously with the words: "CAUTION BURIED WATER LINE BELOW" on potable water pipe.
- C. All nonmetallic recycled water mains shall include a continuous 12 gage, single-strand copper wire with purple insulation, taped to the top of the pipe and extended upwards into all valve boxes.
- D. Plastic warning tape shall be installed over all recycle water lines as shown on Standard Drawing DWD 1. Warning tape shall be purple, minimum 6 inches wide, and printed continuously with the words: "CAUTION RECYCLED WATER LINE – DO NOT DRINK", or equivalent, for recycled water pipe.

## **PART 3 EXECUTION**

### **3.01 GENERAL**

- A. At each bell location, the bedding must be slightly excavated to accommodate the larger outside diameter. The pipe section shall receive continuous support and not rest upon the bell.

### **3.02 INSTALLATION OF PVC PIPE AND FITTINGS FOR WATER SERVICE**

- A. PVC pipe and fittings shall be installed in accordance with instructions of the manufacturer, ASTM D2321, AWWA C605, AWWA Manual No. 23, or as otherwise specified herein.
- B. When cutting pipe is required, the cutting shall be done by machine, leaving a smooth cut at right angles to the axis of the pipe. Care shall be taken to cut the pipe squarely. Cut ends of pipe to be used with a bell shall be beveled to conform to the manufactured spigot end. The Contractor shall use manufacturer provided closure pipe to make field adjustments to pipe length.

- C. Care shall be taken to avoid impacting or over bending the pipe. No loads of AASHTO HS-20 magnitude shall be applied with less than the required design cover over the pipe.
- D. PVC pipe may be deflected or manually bent into place if allowed by the Manufacturer. A combination of deflection at the joint and bending of the pipe is not allowed. With a maximum angular deflection at the joint of 1 degree for jointed PVC pipe over 6" diameter, the maximum allowable bending offset per 20-foot length is given in the following table:

Pipe Size (Inches)	Maximum Allowable Bending Offset (Inches)	Resulting Centerline Radius of Curvature (feet)
4*	47	50
6*	33	72
8**	4.2	1,146
10**	4.2	1,146
12**	4.2	1,146
* Assumes bending along the pipe		
** Assumes axial joint deflection		

- E. Restrained joints shall be installed where shown on the Drawings.

### 3.03 JOINTING PVC PIPE FOR POTABLE WATER SERVICE (Push-on type)

- A. PVC water pipe and fittings shall be jointed in accordance with the latest AWWA standards and detailed instructions of the manufacturer. Pipe shall be laid with bell ends looking ahead.
- B. Before any joint is made, the pipe shall be checked to assure that a close joint with the next adjoining pipe has been maintained and that the inverts are matched and conform to the required grade. The pipe shall not be driven down to grade by striking it.
- C. Bell/spigot joints will be assembled by inserting spigots into in-place bells. The gasket, spigot, and bell must be clean to ensure that the gasket is properly seated. Spigots and bells shall be generously lubricated with a vegetable-base lubricant supplied by the pipe manufacturer. The pipe spigot shall then be inserted into the bell in accordance with the manufacturer's recommendations.
- D. Each length of the pipe shall be shoved home against the pipe previously laid and held securely until enough backfill has been placed to hold the pipe in place. Joints shall not be "pulled" or "cramped".

### 3.04 JOINTING PVC PIPE FOR POTABLE WATER SERVICE (Fusible PVC)

- A. Fusible PVC pipe and fittings shall be jointed in conformance with AWWA 900, AWWA C905, ASTM D2241 or ASTM D1785 for standard dimensions, as applicable. Testing shall be in accordance with the referenced AWWA standards for all pipe types.

- B. Fusible PVC pipe shall be extruded with plain ends. The ends shall be square to the pipe and free of any bevel or chamfer. There shall be no bell or gasket of any kind incorporated into the pipe.
- C. Fusible PVC pipe shall be manufactured in custom lengths as specified in the plans.
- D. Unless otherwise specified, fusible PVC pipe lengths shall be assembled in the field with butt-fused joints. The Contractor shall follow the pipe supplier's written guidelines for this procedure.

### **3.05 JOINTING MECHANICAL JOINT FITTINGS FOR POTABLE WATER SERVICE**

- A. Mechanical joints at valves, fittings and where designated shall be in accordance with the AWWA C111 and the instructions of the manufacturer. Suitable PVC to ductile iron adaptors shall be installed prior to installing fittings. PVC beveled spigot shall be cut flush prior to insertion in mechanical joint pipe. To assemble the joints in the field, thoroughly clean the joint surfaces and rubber gasket with soapy water before tightening the bolts. Bolts shall be tight to the specified torques. Bolts, nuts, and washers for flanges shall be 316 stainless steel. Under no condition shall extension wrenches or pipe over handle of ordinary ratchet wrench be used to secure greater leverage.

### **3.06 ACCEPTANCE TESTING**

- A. PVC pipes for potable water systems shall be flushed, pressure tested, and disinfected in accordance with Section 02675.
- B. PVC pipes for recycled water systems shall be flushed and pressure tested in accordance with Section 02675. Potable or recycled water may be used.
- C. The Contractor is responsible for proper disposal of all flush and testing water in a manner that will not cause damage and/or nuisance to the environment and in compliance with state and local regulations.
- D. Where both potable and recycled water customer facilities exist at a site, a cross connection inspection test shall be performed on both the potable and recycled water systems. Coverage test shall be performed on the recycled water irrigation system to ensure overspray and runoff is in accordance with California regulations.

END OF SECTION

## SECTION 02675

### WATER PIPELINE TESTING AND DISINFECTION

#### PART 1 GENERAL

##### 1.01 SCOPE OF WORK

- A. Furnish all labor, materials, equipment and incidentals required and test and clean all new potable water pipelines of 6 inches and greater installed under this Contract as specified herein. Chlorinate and perform bacteriological testing of all potable water lines, for all sizes, as detailed in this Section.

##### 1.02 SUBMITTALS

- A. Contractor shall submit the following to the District:
  - 1. Flushing and Disinfection Testing Plan
    - a. Plan should include:
      - i. Identification of Piping Tested
      - ii. Test Fluid
      - iii. Test Pressure
      - iv. Disinfection Submittal – Submittal 16
      - v. Chlorine Dosing Method and Calculations
      - vi. Flushing Method and Velocity Calculations
      - vii. Signatures of Contractor and Construction Manager
  - 2. Test Records
    - a. Records shall be maintained of all tests performed.
    - b. Test records shall include:
      - i. Date of Testing
      - ii. Identification of Piping Tested
      - iii. Test Fluid
      - iv. Test Pressure
      - v. Disinfection Submittal

- vi. Chlorine Dosing Calculation
  - vii. Flushing Velocity Calculations
  - viii. Signatures of Contractor and Construction Manager
3. If leaks are found, they shall be noted, on the record. After correction, perform retesting as specified for original test.
  4. Records of test shall be maintained by the Contractor and two (2) copies furnished to the District.

### **1.03 REFERENCE STANDARDS**

- A. Where references are noted, the most recent version or edition shall be used.
- B. American Water Works Association (AWWA)
  1. AWWA C600 – Installation of Ductile-Iron Water Mains and Their Appurtenances
  2. AWWA C605 – Underground Installation of Polyvinyl Chloride (PVC) Pressure Pipe and Fittings
  3. AWWA C651 – Disinfecting Water Mains

## **PART 2 PRODUCTS**

### **2.01 TEST EQUIPMENT**

- A. Hydrostatic Test (Pressure Pipes)
  1. Water - From the District's existing water system.
  2. Pump – Install water meter in-line with pump to measure water use to maintain pressure.
  3. Strainer - On inlet side of the pump to prevent foreign matter from entering the system.
  4. Valves - Shall be provided on the suction and discharge side of the pump.
  5. Relief Valve - Set at a pressure to relieve at 20 to 25 percent above the required test pressure.
  6. Pressure Gage(s) - Capable of reaching 50 percent over the test pressure. These should be located at the pump discharge and any other place deemed convenient by the Contractor.
  7. Pressure gages and relief valves shall be checked for accuracy before use in test procedures.

## **PART 3 EXECUTION**

### **3.01 GENERAL**

- A. Furnish all necessary equipment and labor for cleaning, testing and chlorinating the pipelines. The procedures and methods shall be approved by the District.
- B. Make any taps and furnish all necessary caps, plugs, etc, as required in conjunction with testing pipelines. Furnish a test pump, gauges and any other equipment required in conjunction with carrying out the hydrostatic tests.
- C. Any connection between the new pipeline and the existing water system shall include a double-check valve assembly installed to prevent flow into the existing system. The double-check valve assembly shall be required until bacteriological sampling proves the new pipeline is properly disinfected. Only a DHS approved double-check valve passing the District's backflow test shall be used by the Contractor.
- D. After the completion of sufficient backfill, the newly laid pipe or any valve section thereof, shall be subjected to two hydrostatic pressure tests. One pressure test will be conducted prior to the placement of the subbase and/or base of the roadway. The second pressure test will be conducted immediately prior to paving of the roadway or after one lift, but before the final lift, where more than one lift is to be used.
- E. Any leaks, failures, or imperfect construction that develops during any test shall be repaired by the Contractor, and the test repeated until the system is proved satisfactory.

### **3.02 TESTING PRESSURE PIPELINES**

- A. This test specification shall be used to hydrostatically test piping systems for structural integrity and leaks as specified herein and in AWWA C600. The test shall be performed at ambient temperature unless otherwise specified.
- B. Preparation for Test
  - 1. Vents shall be provided at the high points of the system and drains provided where means of venting or draining do not exist.
  - 2. Remove or block off, all relief valves, rupture discs, alarms, control instruments, etc. that shall not be subjected to the test pressure.
  - 3. All discs, balls, or pistons from check valves shall be removed if they interfere with filling of the system. Open all valves between inlet and outlet of the section to be tested.
  - 4. Connect pump and provide temporary closures for all of the external openings in the system. Use caution to ensure that the closures are properly designed and strong enough to withstand the test pressure.

5. A joint previously tested in accordance with this specification may be covered or insulated.
6. Expansion joints shall be provided with temporary restraint for additional pressure under test or shall be isolated from the test.
7. Flanged joints, where blanks are inserted to isolate equipment during the test, need not be tested.

C. Test Procedures

1. Any connection between the new pipeline being installed and the existing water system shall include a state approved double-check valve assembly installed to prevent flow into the existing system. The device shall be tested by Diablo Water District prior to being made available to the new mains. Any devices that fail the test shall be repaired to the satisfaction of the District. The backflow device assembly shall be required until bacteriological sampling proves the new pipeline is properly disinfected. The contractor shall pay costs of all water used for construction purposes, including pipeline flushing and testing. The contractor is required to use a District furnished meter and to pay the required deposit for meter use. District meters are 3-inch in size. The Contractor, at his expense, shall provide a larger meter if required to complete the work. Any meter, other than that furnished by the District, will require prior District approval.
2. The test section shall be slowly filled with potable water. Open vents to allow displacement of all entrapped air. For all pipelines exceeding 500 feet in length, the maximum rate of filling shall be limited to that which produces a maximum nominal flow velocity of one foot per second in the pipe to be tested.
3. Close vents and restrict personnel in the test area to those involved in the test.
4. Raise the pressure slowly with the pump until the predetermined test pressure is reached. Maintain pressure for four hours keeping personnel at a safe distance.
5. Reduce the pressure about 20 percent and hold it at that point while the entire system is carefully inspected for leaks, cracks, or other signs of defects. No leakage will be permitted for any pipe being tested.
6. If any leaks, failures or imperfect construction that develops during any test are found, the pressure shall be released, and the system drained. The defects shall be corrected by the Contractor, and the test repeated.
7. After a satisfactory test has been completed, the line shall be drained.

- D. Testing of PVC Pipe
1. The duration of the test shall be four hours and the pipe shall be subjected to a hydrostatic pressure of 50 percent above the normal operating pressure, or 150 pounds per square inch, whichever is greater. In no case shall the test pressure be allowed to exceed the design pressure for pipe, appurtenances, or thrust restraints. No leakage will be permitted.
- E. Testing of Ductile Iron Pipe
1. The duration of the test shall be four hours and the pipe shall be subjected to a hydrostatic pressure of 50 percent above the normal operating pressure, or 150 pounds per square inch, whichever is greater. In no case shall the test pressure be allowed to exceed the design pressure for pipe, appurtenances, or thrust restraints. No leakage will be permitted.
- F. Testing of Steel Pipe
1. All pipelines shall be tested by subjecting each section to a pressure, measured at the lowest end of the section, of at least 150 percent of the class rating or design pressure of pipe under test. In no case shall the pipe be tested at less than 150 pounds per square inch, nor shall the test pressure be allowed to exceed the design pressure for pipe, appurtenances, or thrust restraints. No leakage will be permitted.
  2. The test may be made before or after backfilling. However, if mechanical compaction is to be used in the backfilling operations as spelled out in AWWA C600, the test shall not be made until the backfilling is completed and compacted. All connections, blowoffs, hydrants, and valves shall be tested with the main as far as is practicable.
- G. The pressure test on mortar-lined pipe shall not begin until the pipe has been filled with water for at least 24 hours to allow for absorption in the cement mortar lining.

### **3.03 CLEANING**

- A. At the conclusion of the work, thoroughly clean all pipelines by flushing with water or other means to remove all dirt, stones, pieces of wood, or other material which may have entered the pipes during the construction period. Debris cleaned from the lines shall be removed from the low end of the pipeline. If after this cleaning, obstructions remain, they shall be removed. After the pipelines are cleaned and if the groundwater level is above the pipe or following a heavy rain, the Engineer will examine the pipes for leaks. If any further defective pipes or joints are discovered, the Contractor shall repair them. Finished paving shall not be installed prior to completion of all cleaning and testing.



### **3.04 DISINFECTION OF PIPELINES**

- A. After completion of the hydrostatic test, the mains shall be thoroughly flushed with a minimum pipe velocity of 3 fps and chlorinated in accordance with the latest revision of AWWA 651, Standards of Disinfecting Water Mains. Any one of the methods therein described may be used, with the additional requirement of 50 ppm chlorination minimum initial application. At the end of the contact period, the mains shall again be flushed, and bacteriological samples taken by the District.
- B. If necessary, the Contractor shall provide, at their expense, outlets from which to take the samples. The location of the chlorination and sampling points will be determined by the District in the field. Taps for chlorination and sampling shall be installed. The Contractor shall uncover and backfill the taps as required.
- C. Disinfection of tie-ins shall be performed by the Contractor by swabbing with chlorine or by other approved methods. Following a tie-in, the area affected by the tie-in shall be thoroughly flushed and bacteriological samples will be taken by the District as deemed necessary.
- D. All treated water flushed from the lines shall be dechlorinated and disposed of by discharging to the locations identified in the Drawings, or by other approved means. No discharge of chlorinated water to any storm sewer or natural water course will be allowed, unless properly dechlorinated.
- E. The Contractor shall rechlorinate and retest any lines that do not meet the requirements of the above testing. The line shall not be placed in service until the requirements of the State Public Health Department are met.

### **3.05 BACTERIOLOGICAL TESTING**

- A. The District shall take water samples for bacteriological testing for approximately every 500 feet of water main, with a minimum of two samples and one sample from each dead end. After the samples have passed the bacteriological testing, the Contractor will be notified and arrangements can be made to make tie-ins and connections to house services. Each water sample will have passed the bacteria tests if they show zero total coliform per 100 mL, not more than 50 non-sheen bacteria per 100 mL, not more than 250 HPC CFU/mL, and when the turbidity is no greater than the source water. Samples shall be taken no sooner than 24 hours after final flushing.
- B. After 24-hours, the District will grab another round of sampling. The second round of samples will be evaluated on a presence/absence basis. The second round of sampling happens before the jumper is pulled and tie-ins are made. Each sample will pass the bacteria tests if they show zero total coliform per 100 mL and not more than 250 HPC CFU/mL.
- C. Jumpers and/or plates shall be pulled within 14 days of the notification of a successful second test, or new bacteria samples will have to be taken. Follow-up bacteriological testing shall take place after tie-ins have been made, and shall meet the passing requirements as the initial tests.

- D. The Contractor shall rechlorinate and retest any lines that do not pass the first or subsequent round of bacteriological testing as directed by the District.

END OF SECTION

## SECTION 02830

### CHAIN LINK FENCES AND GATES

#### PART 1 GENERAL

##### 1.01 SCOPE OF WORK

- A. The Contractor shall provide all materials, equipment, labor and supervision necessary to furnish and install chain link fencing and gates, and all appurtenant work, complete in place, as shown on the Drawings and as specified herein.
- B. Where the Work requires temporary removal and replacement of existing fences, the fences shall match the adjacent fence.
- C. Fence shall be used to enclose detector check valves, water meters, and other water piping shall be constructed of materials as described below.

##### 1.02 REFERENCE STANDARDS

- A. Where references are noted, the most recent version or edition shall be used.
- B. California Department of Transportation
  - 1. Standard Specifications:
    - Section 80-3 Chain Link Fences
    - Section 90 Portland Cement Concrete
- C. American Society for Testing and Materials
  - ASTM F668 Standard Specification for Polyvinyl Chloride (PVC), Polyolefin and Other Polymer-Coated Steel Chain Link Fence Fabric

##### 1.03 CONTRACTOR SUBMITTALS

- A. Certificates of Compliance: Certificates of Compliance shall be provided for all products and materials proposed to be used under this Section.
- B. Product data sheets for gates, typical fence construction, and fence corner construction shall be submitted to the District for review prior to fabrication and construction.

## **PART 2 PRODUCTS**

### **2.01 GENERAL**

- A. Fencing shall be as shown on the Drawings. All fencing materials shall be hot-dip galvanized after fabrication and coated with Class 2b fused black PVC coating, minimum 6 mils thickness, meeting the requirements of ASTM F668. Fencing should be topped with 3 lines of barbed wire unless otherwise shown. All materials and components shall be new, first quality items specifically manufactured for the intended application.
- B. All galvanized fence material shall be galvanized in accordance with Section 80-3, "Chain Link Fence," of the Caltrans Standard Specifications. All steel parts shall be hot-dipped galvanized prior to vinyl coating.

### **2.02 MATERIALS**

- A. Fence fabric shall be No. 9 gage galvanized steel wire, 2 inch mesh. The fabric shall have a knuckled finish on the top, and a twisted and barbed finish on the bottom edge. The fabric shall be black PVC coated.
- B. Fabric ties shall be galvanized steel wire of the same gage as fence fabric, spaced 14 inches apart on posts. Aluminum ties will not be permitted. A continuous No. 7 gage galvanized steel tension wire shall be interlaced with the fabric or attached to the fabric with clips along the extreme top and bottom of the fence. Fabric ties shall be PVC coated the same as the fence fabric.
- C. Posts shall be one-piece without circumferential welds, shall be black PVC coated, or have 7 mils dry film thickness of phenolic baked phosphate enamel capable of 250 hours of salt spray test, and shall meet the following:
  - 1. Line Posts shall be 2-1/2 inch Schedule 40 pipe, 3.65 lb./ft.
  - 2. End and Corner Posts shall be 2-7/8 inch Schedule 40 pipe, 5.79 lb./ft.
  - 3. Gate posts shall be 3-1/2 inch Schedule 40 pipe, 9.1 lb./ft.
- D. Post tops shall be galvanized pressed steel, malleable iron, or cast aluminum; designed to fit over the outside of the posts and to prevent entry of moisture into the tubular posts. Post tops shall be black PVC coated.
- E. Top rail and braces shall be 1-5/8 inch Schedule 40 pipe, 1.4 lb./ft., and shall be coated the same as posts.
- F. Rail couplings shall be sleeve type, 6 inches long.
- G. Barbed wire shall be 2-strand, No. 12-1/2 gage zinc-coated steel or iron wire with 4-point, 12-gage barbs spaced not more than 5 inches apart and shall be PVC-coated the same as for fence fabric. Outriggers shall be black PVC coated.

- H. Truss Rod and turn buckle shall be in conformance with Section 80-3, "Chain Link Fence," of the Caltrans Standard Specifications. Bracing shall be the same as the top rail, with 3/8 inch diameter galvanized steel rod truss and tightener.
- I. Fence stretcher bars shall be 1/4 inch by 3/4 inch galvanized steel bars, and steel bands for fastening stretcher bars to the posts shall be 1/8 inch by 3/4 inch. Both shall be black PVC coated.
- J. Nuts, bolts and screws shall be of steel, hot-dipped galvanized after fabrication, minimum size 3/8 inch diameter. All nuts bolts and screws shall be coated with 7 mils dry film thickness of phenolic baked phosphate enamel capable of 250 hours of salt spray test.
- K. Fence swing gate frames shall be constructed of 1-7/8 inch outer diameter galvanized steel tubing, 2.09 lb./ft., and shall be fabricated by welding with all welds ground smooth prior to hot-dip galvanizing. Gates shall be hinged to swing 180 degrees from closed to open, complete with frames, latches, stops, and hinges. Each gate leaf shall be provided with at least one diagonal brace, free from sag or twist. Frames shall be galvanized and PVC-coated after fabrication. Galvanized malleable iron fittings for latching the gate shall be provided. Swing gates shall be hung by at least 2 steel or malleable iron hinges not less than 3 inches in width. Joints between frame member shall be made by welding or by means of heavy fittings, and shall be rigid and watertight. Hinges shall be heavy pattern with large bearing surfaces and shall not twist or turn under the action of the gate. Fabric shall match the fabric used in the fence. Each pair of gates shall be provided with a heavy drop rod latch assembly with a locking device for a padlock. Gates shall be installed so that they cannot be removed without disassembly of the hardware. Hardware attachment bolts shall be peened so that removal will be difficult. PVC coatings shall be as specified for the various fence elements.

## **PART 3 EXECUTION**

### **3.01 INSTALLATION**

- A. All earth, brush, or other obstructions which interfere with the proper alignment of construction of fences and gates shall be removed and disposed of at the expense of the Contractor.
- B. Fence line posts shall be spaced at not more than 10-foot intervals, measured from center to center of the posts and measured generally parallel to the ground slope. Line posts shall be set plumb and shall be centered in 12-inch diameter concrete footings extending 39 inches into the ground.
- C. Fence end posts and corner posts shall be set plumb, and shall be centered in 12 inch diameter concrete footings extending 39 inches into the ground.
- D. Gate posts shall be provided with a concrete footing in accordance with the manufacturer's printed recommendation.

- E. Concrete shall be a 5-sack mix and shall be properly mixed before placing. Concrete for footings shall be placed immediately after mixing in a manner such that there will be no concentration of the large aggregates. The concrete shall be consolidated by tamping or vibrating in an approved manner. Concrete for footings may be placed without forms, providing the ground is firm enough to permit excavation to neat line dimensions. Prior to placing the concrete, the earth around the hole shall be thoroughly moistened. The concrete shall completely fill the hole and top surfaces of the concrete shall be crowned and sloped away from the post to shed water and shall have a neat appearance. Not less than 7 days shall elapse after placing the concrete footings before the fence fabric is fastened to the posts.
- F. Top rails and bottom tension wires shall be installed before the fabric. Top rails shall be securely connected to gate and terminal posts. Tension wires shall be installed approximately 6 inches above grade and shall be attached to each post and securely anchored at terminal and gate posts.
- G. Where a horizontal fence alignment angle is 15 degrees or more, corner posts shall be installed in lieu of line posts.
- H. Bracing shall be provided at all end, gate, and corner posts, the latter in both directions. Horizontal brace rails shall be set 6 inches below top of fence fabric running from the corner, end, or gate post to first line post. Diagonal tension members shall connect tautly between posts below horizontal braces.
- I. Fence corner posts shall be installed in lieu of line posts at intervals not exceeding 500 feet and shall be braced horizontally in both directions.
- J. The fabric shall be fastened on the side of the posts as shown or as designated by the District. The fabric shall be stretched and securely fastened to the posts, and between the posts the fabric shall be fastened to the top and bottom tension wires and the truss rod. The truss rod shall be stretched tight with turnbuckles at the end and corner posts.
- K. The fabric shall be fastened to the end, corner, and gate posts with stretcher bars and stretcher bar bands spaced at approximately 14 inches on line posts and at approximately 18 inches on tension wires.
- L. Any PVC-coating damaged during construction of the fencing shall be repaired as recommended by the fencing manufacturer
- M. Outriggers and barb wire strands shall be installed upon completion of the chain link fencing. All barb wire strands shall be strung and taught as chain link fabric. All outriggers shall be oriented perpendicular to the fence line and pointing away from the project site.

Related drawings: DWD 14

END OF SECTION

## SECTION 03304

### CONCRETE AND REINFORCING STEEL FOR THRUST BLOCKS

#### PART 1 GENERAL

##### 1.01 SCOPE OF WORK

- A. Furnish all labor, materials, equipment and incidentals required and install all concrete work as shown on the Drawings and as specified herein for thrust blocks and other support items as required by the District.

##### 1.02 SUBMITTALS

- A. Submit to the District shop drawings and product data. Submittals shall include at least the following:
  - 1. Concrete mix for each formulation of concrete proposed for use including constituent quantities per cubic yard, water cementitious material ratio, type and manufacturer of cement, and admixtures.
  - 2. Technical data on all materials and components.
  - 3. Safety Data Sheets (SDS) for all concrete admixtures and curing agents.
- B. Test Reports
  - 1. Sieve analysis of fine and coarse aggregates.
  - 2. Concrete mix for each formulation of concrete proposed for use including constituent quantities per cubic yard, water cementitious material ratio, type and manufacturer of cement, and admixtures.
    - a. Standard deviation data for each proposed concrete mix based on statistical records. Provide data on 28, 14, and 7 day compressive strength.

##### 1.03 REFERENCE STANDARDS

- A. Referenced standards shall be the most recent version or edition.
- B. American Society for Testing and Materials (ASTM)
  - 1. ASTM A615 – Standard Specification for Deformed and Plain Carbon-Steel Bars for Concrete Reinforcement
  - 2. ASTM A706 – Standard Specification for Deformed and Plain Low-Alloy Steel Bars for Concrete Reinforcement

3. ASTM C31 – Standard Practice for Making and Curing Concrete Test Specimens in the Field
  4. ASTM C33 – Standard Specification for Concrete Aggregates
  5. ASTM C94 – Standard Specification for Ready-Mixed Concrete
  6. ASTM C143 – Standard Test Method for Slump of Hydraulic-Cement Concrete
  7. ASTM C150 – Standard Specification for Portland Cement
  8. ASTM C173 – Standard Test Method for Air Content of Freshly Mixed Concrete by the Volumetric Method
  9. ASTM C231 – Standard Test Method for Air Content of Freshly Mixed Concrete by the Pressure Method
  10. ASTM C260 – Standard Specification for Air-Entraining Admixtures for Concrete
  11. ASTM C494 – Standard Specification for Chemical Admixtures for Concrete
- C. American Concrete Institute (ACI).
1. ACI 211.1 – Standard Practice for Selecting Proportions for Normal, Heavyweight and Mass Concrete
- D. Concrete Reinforcing Steel Institute (CRSI)
1. MSP – Manual of Standard Practice

## **PART 2 PRODUCTS**

### **2.01 MATERIALS**

- A. Cement shall be domestic portland cement conforming to ASTM C150. The allowable types of cement for each concrete class are shown in Table 1. Air entraining cements shall not be used.
- B. Fine aggregate shall be washed inert natural sand conforming to the requirements of ASTM C33.
- C. Coarse aggregate shall be a well-graded crushed stone or washed gravel conforming to the requirements of ASTM C33, size 57. Limits of Deleterious Substances and Physical Property Requirements shall be as recommended for severe weathering regions.



- D. Water shall be potable, clean and free from injurious amounts of oils, acids, alkalis, organic matter, or other deleterious substances.
- E. Reinforcing steel bars shall be deformed steel conforming to ASTM A706. ASTM A615 Grade 60 may be used for ASTM A706 provided the following requirements are satisfied:
  - 1. The actual yield strength of the reinforcing steel based on mill tests shall not exceed the specified yield strength by more than 18,000 psi. Retests shall not exceed this value by more than an additional 3000 psi.
  - 2. The ratio of the actual ultimate tensile strength to the actual tensile yield strength of the reinforcement shall not be less than 1.25.
  - 3. The carbon equivalency (CE) of A615 bars shall be 0.55 or less.
- F. Tie wires for reinforcing steel shall be 16 gauge or heavier, black annealed wire.

## **2.02 MIXES**

- A. Development of mix designs and testing shall be by an independent testing laboratory acceptable to the District engaged by the Contractor.
- B. Select proportions of ingredients to meet the design strength and materials limits specified in Table 1 and to produce concrete having proper placability, durability, strength, appearance and other required properties. Proportion ingredients to produce a homogenous mixture which will readily work into corners and angles of forms and around reinforcement without permitting materials to segregate or allowing excessive free water to collect on the surface.
- C. The design of each mix shall be based on standard deviation data of prior mixes with essentially the same proportions of the same constituents or, if not available, be developed by independent testing laboratory acceptable to the District engaged by and at the expense of the Contractor. Acceptance of mixes based on standard deviation shall be based on the modification factors for standard deviation tests contained in ACI 318. Acceptance of mixes based on laboratory tests shall be based on strengths greater than the required design strengths specified in ACI 318. The water content of the concrete mixes to be used, as determined from the curve, shall correspond to strengths 16 percent greater than the required design strength. The resulting mix shall not conflict with the limiting values for maximum water cementitious material ratio and net minimum cementitious content as specified in Table 1.

TABLE 1									
Class Range	Description	Design Strength <sup>(1)</sup>	Cement ASTM C150	Number of Sacks	Cement Content (lbs) <sup>(2)</sup>	Fly Ash (%)	W/C <sup>(3)</sup>	WR <sup>(4)</sup>	Slump (inches)
A	Structural Concrete	4,000	Type I or Type II	6 sacks	564	15-20	0.94 max	yes	2-4
B	Thrust Blocks, All Other Concrete	3,000	Type I or Type II	5 sacks	470	15-20	0.54 max	yes	3-5

All concrete classes have 3.5 to 5 percent air entrainment, except for concrete slabs which shall be less than 3 percent. Fine aggregate shall be in accordance with ASTM C33. Coarse aggregate shall be in accordance with ASTM C33, size number 57.

**NOTES:**

- (1) Minimum compressive strength in lbs/cu in at 28 days.
- (2) Minimum cement content in lbs/cu yd.
- (3) W/C is Water Cementitious Material ratio.
- (4) WR is Water Reducing Admixture.

D. Compression Tests: If prior mix test data is not available, provide testing of the proposed concrete mix or mixes to demonstrate compliance with the compression strength requirements in conformity with the provisions of ACI 318.

**2.03 THRUST BLOCKS**

A. Thrust blocks shall be Class B (5 sacks cement per cubic yard) concrete.

**PART 3 EXECUTION**

**3.01 REINFORCING STEEL**

- A. Reinforcing steel shall be accurately fabricated to the dimensions shown. Bars shall be bent around a revolving collar having a diameter of not less than that recommended in ACI 318. All bars shall be bent cold.
- B. Except as otherwise indicated on the Drawings, the minimum concrete cover of reinforcement shall be as follows:
  - 1. Concrete cast against and permanently exposed to earth: 3 inches.
  - 2. Concrete exposed to soil, water, and/or weather: 2 inches.
- C. Unless otherwise shown, splices in reinforcing steel shall be tension lap splices in compliance with Chapter 21 of ACI 318 entitled "Special Provisions for Seismic Design". All bar splices shall be staggered wherever possible. When splicing bars of different diameters, the length of lap is based on the larger bar.
- D. In no case shall any reinforcing steel be covered with concrete until the amount, condition, and position of the reinforcements have been checked by the District and permission is given to proceed with the concreting.

### **3.02 INSPECTION AND COORDINATION**

- A. The batching, mixing, transporting, placing and curing of concrete shall be subject to the inspection of the District at all times. The Contractor shall advise the District of their readiness to proceed at least 48 hours prior to each concrete placement. The District will inspect the preparations for concreting including the preparation of previously placed concrete, the reinforcing and the alignment, cleanliness and tightness of formwork. No placement shall be made without the inspection and acceptance of the District.

### **3.03 CONCRETE APPEARANCE**

- A. Concrete mix showing either poor cohesion or poor coating of the coarse aggregate with paste shall be remixed. If this does not correct the condition, the concrete shall be rejected.
- B. Concrete for the work shall provide a homogeneous structure which, when hardened, will have the required strength, durability and appearance.

### **3.04 PLACING AND COMPACTING**

- A. No concrete shall be placed until forms, condition of subgrade and method of placement have been approved by the District. Before depositing concrete, all debris, foreign matter, dirt and water shall be removed from the forms. The contact surface between concrete previously placed and new concrete shall be cleaned and brushed with cement paste. Concrete except as indicated shall not be placed in water or submerged within 24 hours after placing, nor shall running water be permitted to flow over the surface of fresh concrete within 4 days after its placing.
- B. Deposit concrete as near its final position as possible to avoid segregation due to rehandling or flowing. Pumping of concrete will be permitted when an approved design mix and aggregate sizes, suitable for pumping, are used. Do not deposit concrete which has partially hardened or has been contaminated by foreign materials.
- C. High frequency mechanical vibrators shall be used to the extent necessary to obtain proper consolidation of the concrete, but not to move or transport concrete in the forms. Care shall be taken to avoid segregation of aggregates by excess vibration. Vibration shall continue until the frequency returns to normal, trapped air ceases to rise and the surface appears liquefied, flattened and glistening. Concrete adjacent to forms and around pipe stubs shall be carefully spaded or rodded.

### **3.05 THRUST BLOCKS**

- A. Thrust blocks shall be cast-in-place at all bends, behind each tee or each cross which is valved in such a manner that it can act as a tee, at reducers, and at the bury of fire hydrants. The thrust block shall extend from the fitting to undisturbed soil, shall be kept clear of the joints, and shall be of such bearing area as to assure adequate resistance to the force to be encountered. Installation shall ensure T-bolts on the fittings are free from concrete and accessible. Thrust block poured against blind flanges or blowoffs shall be done in such a fashion as to allow access to the flange bolts.

### **3.06 CURING AND PROTECTION**

- A. Protect all concrete work against injury from the elements and defacements of any nature during construction operations.
- B. Finished surfaces and slabs shall be protected from the direct rays of the sun to prevent checking and crazing.
- C. Concrete placed during hot weather, shall be batched, delivered, placed, cured and protected in compliance with the recommendations of ACI 305R. The temperature of the concrete shall be such that it will cause no difficulties from loss of slump, flash set or cold joints. Immediately cover plastic concrete with sheet material during hot weather.

### **3.07 FIELD TESTS**

- A. Field control cylinder specimens will be taken by the District during the progress of the work, in compliance with ASTM C31. When the required 28 day compressive strength is not met, the District may require the removal and replacement of concrete represented by the test cylinders at no additional cost to the District.
- B. Contractor shall cooperate in the making of tests by allowing free access to the work for the selection of samples, providing an insulated closed curing box for specimens, affording protection to the specimens against injury or loss through their operations and furnishing material and labor required for the purpose of taking concrete cylinder samples.
- C. Slump tests will be made in the field by the District in conformity with ASTM C143.
- D. Tests for air content shall be made in compliance with either the pressure method complying with ASTM C231 or by the volumetric method complying with ASTM C173.

E. Shrinkage

1. Field test specimens shall be handled and tested by the District as specified herein under "Concrete Mix Design - Shrinkage Tests". A set of test cylinders shall be taken from the first batch of concrete and any initial batch thereafter in which the source of concrete ingredients has changed.
2. The maximum concrete shrinkage of specimens cast in the field shall not exceed the trial batch maximum shrinkage requirement by more than 25 percent.
3. If the required shrinkage limitation is not met during construction, the Contractor shall take any or all of the following actions to achieve the specified shrinkage requirements. These actions may include changing the source of aggregates, cement and/or admixtures; reducing water content; washing of aggregate to reduce fines; increasing the number of construction joints; modifying the curing requirements; or other actions designed to minimize shrinkage or the effects of shrinkage.

**3.08 STRIPPING AND FINISHING CONCRETE**

- A. Forms shall not be stripped before the concrete has attained a strength of at least 30 percent of the ultimate design strength, except as otherwise specified.
- B. Care shall be exercised to prevent damaging edges or obliterating the lines of chamfers, rustications or corners when removing the forms or doing any other work adjacent thereto.
- C. All exposed concrete other than slabs shall be given a sacked finish.

Related drawings:      DWD 2  
                                 DWD 3  
                                 DWD 4  
                                 DWD 9  
                                 DWD 17

END OF SECTION

## SECTION 03600

### CEMENT MORTAR AND GROUT

#### PART 1 GENERAL

##### 1.01 SUMMARY OF SECTION

- A. Furnish all labor, materials, equipment and incidentals required and install grout complete as shown on the Drawings and as specified herein.
- B. Perform all sampling and furnish all testing of materials and products by an independent testing laboratory acceptable to the Engineer but engaged by and at the expense of the Contractor.

##### 1.02 SUBMITTALS

- A. Submit to the Engineer, in accordance with Section 01300, shop drawings and product data showing materials of construction and details of installation for:
  - 1. Commercially manufactured nonshrink cementitious grout. The submittal shall include catalog cuts, technical data, storage requirements, product life, working time after mixing, temperature considerations, conformity to required ASTM standards and Material Safety Data Sheets.
  - 2. Commercially manufactured nonshrink epoxy grout. The submittal shall include catalog cuts, technical data, storage requirements, product life, working time after mixing, temperature considerations, conformity to required ASTM standards and Material Safety Data Sheets.
- B. Samples
  - 1. Samples of commercially manufactured grout products when requested by the Engineer.
  - 2. Aggregates for use in concrete grout when requested by the Engineer.
- C. Laboratory Test Reports
  - 1. Submit laboratory test data as required under Section 03304 for concrete to be used as concrete grout.

### **1.03 REFERENCE STANDARDS**

- A. Referenced standards shall be the most recent version or edition.
- B. American Society for Testing and Materials (ASTM)
  - 1. ASTM C531 – Standard Test Method for Linear Shrinkage and Coefficient of Thermal Expansion of Chemical-Resistant Mortars, Grouts, Monolithic Surfacing, and Polymer Concretes
  - 2. ASTM C827 – Standard Test Method for Change in Height at Early Ages of Cylindrical Specimens from Cementitious Mixtures
  - 3. ASTM C1107 – Standard Specification for Packaged Dry, Hydraulic-Cement Grout (Nonshrink)

### **1.04 QUALITY ASSURANCE**

- A. Qualifications
  - 1. Grout manufacturer shall have a minimum of 10 years experience in the production and use of the type of grout proposed for the work.

### **1.05 DELIVERY, STORAGE AND HANDLING**

- A. Store materials in full compliance with the manufacturer's recommendations. Total storage time from date of manufacture to date of installation shall be limited to 12 months or the manufacturer's recommended storage time, whichever is less.
- B. Material which becomes damp or otherwise unacceptable shall be immediately removed from the site and replaced with acceptable material.

## **PART 2 PRODUCTS**

### **2.01 MATERIALS**

- A. Certify that mortar and grout constituents in contact and/or may be in contact with water used for potable purposes, including the air space around these areas, are NSF/ANSI 61 compliant, with certifications from an independent ANSI/Environmental Laboratory Accreditation Program - accredited testing laboratory acceptable to the Engineer.
- B. Nonshrink Cementitious Grout (Nonshrink Grout)
  - 1. Nonshrink grouts shall meet or exceed the requirements of ASTM C1107 Grades B or C and CRD-C 621. Grouts shall be portland cement based, contain a pre-proportioned blend of selected aggregates and shrinkage compensating agents and shall require only the addition of water. Nonshrink grouts shall not contain expansive cement or metallic particles.

The grouts shall exhibit no shrinkage when tested in conformity with ASTM C827.

- a. General purpose nonshrink grout shall conform to the standards stated above and shall be SikaGrout 212 by Sika Corp.; Set Grout by Master Builders, Inc.; Gilco Construction Grout by Gifford Hill & Co.; Euco NS by The Euclid Chemical Co.; NBEC Grout by U. S. Grout Corp. or equal.
- b. Flowable (Precision) nonshrink grout shall conform to the standards stated above and shall be Masterflow 928 by Master Builders, Inc.; Hi-Flow Grout by the Euclid Chemical Co.; SikaGrout 212 by Sika Corp.; Supreme Grout by Gifford Hill & Co.; Five Star Grout by U. S. Grout Corp. or equal.

C. Nonshrink Epoxy Grout

1. Nonshrink epoxy-based grout shall be a pre-proportioned, three component, 100 percent solids system consisting of epoxy resin, hardener, and blended aggregate. It shall have a compressive strength of 14,000 psi in 7 days when tested in conformity with ASTM D695 and have a maximum thermal expansion of  $30 \times 10^{-6}$  when tested in conformity with ASTM C531. The grout shall be Ceilcote 648 CP by Master Builders, Inc.; Five Star Epoxy Grout by U.S. Grout Corp.; Sikadur 42 Grout-Pak by Sika Corp.; High Strength Epoxy Grout by the Euclid Chemical Co. or equal.

D. Cement Grout

1. Cement grouts shall be a mixture of one part Portland cement conforming to ASTM C150, Types I, II, or III and 1 to 2 parts sand conforming to ASTM C33 with sufficient water to place the grout. The water content shall be sufficient to impart workability to the grout but not to the degree that it will allow the grout to flow.

E. Cement Mortar

1. All cement mortar shall consist of 1 part Type II Portland Cement and 1-1/2 parts fine aggregate mixed dry. Sufficient water shall be added and thoroughly mixed to produce a plastic, workable, and cohesive mixture.

## **PART 3 EXECUTION**

### **3.01 PREPARATION**

- A. Grout shall be placed over cured concrete which has attained its full design strength unless otherwise approved by the Engineer.



- B. Concrete surfaces to receive grout shall be clean and sound; free of ice, frost, dirt, grease, oil, curing compounds, laitance and paints and free of all loose material or foreign matter which may affect the bond or performance of the grout.
- C. Roughen concrete surfaces by chipping, sandblasting, or other mechanical means to ensure bond of the grout to the concrete. Remove loose or broken concrete. Irregular voids or projecting coarse aggregate need not be removed if they are sound, free of laitance and firmly embedded into the parent concrete.
  - 1. Air compressors used to clean surfaces in contact with grout shall be the oil-less type or equipped with an oil trap in the air line to prevent oil from being blown onto the surface.
- D. Remove all loose rust, oil or other deleterious substances from metal embedments or bottom of baseplates prior to the installation of the grout.
- E. Concrete surfaces shall be washed clean and then kept moist for at least 24 hours prior to the placement of cementitious or cement grout. Saturation may be achieved by covering the concrete with saturated burlap bags, use of a soaker hose, flooding the surface, or other method acceptable to the Engineer. Upon completion of the 24 hour period, visible water shall be removed from the surface prior to grouting. The use of an adhesive bonding agent in lieu of surface saturation shall only be used when approved by the Engineer for each specific location of grout installation.
- F. Epoxy-based grouts do not require the saturation of the concrete substrate. Surfaces in contact with epoxy grout shall be completely dry before grouting.

### **3.02 INSTALLATION - GENERAL**

- A. Mix, apply and cure products in strict compliance with the manufacturer's recommendations and this Section.
- B. Install grout in a manner which will preserve the isolation between the elements on either side of the joint where grout is placed in the vicinity of a control joint.
- C. Reflect all existing underlying expansion, control and construction joints through the grout.

### **3.03 INSTALLATION – CEMENT GROUTS AND NONSHRINK GROUTS**

- A. Mix in accordance with manufacturer's recommendations. Do not add cement, sand, pea gravel or admixtures without prior approval by the Engineer.
- B. Avoid mixing by hand. Mixing in a mortar mixer (with moving blades) is recommended. Pre-wet the mixer and empty any excess water. Add pre-measured amount of water for mixing, followed by the grout. Begin with the minimum amount of water recommended by the manufacturer and then add the minimum additional water required to obtain workability. Do not exceed the manufacturer's maximum recommended water content.

- C. Placements greater than 3 inches in depth shall include the addition of clean, washed pea gravel to the grout mix when approved by the manufacturer. Comply with the manufacturer's recommendations for the size and amount of aggregate to be added.
- D. Place grout into the designated areas in a manner which will avoid segregation or entrapment of air. Do not vibrate grout to release air or to consolidate the material. Placement should proceed in a manner which will ensure the filling of all spaces and provide full contact between the grout and adjoining surfaces. Provide grout holes as necessary.
- E. Place grout rapidly and continuously to avoid cold joints. Do not place cement grouts in layers. Do not add additional water to the mix (retemper) after initial stiffening.
- F. Begin curing immediately after form removal, cutback, and finishing. Keep grout moist and within its recommended placement temperature range for at least 24 hours after placement or longer if recommended by the manufacturer. Saturate the grout surface by use of wet burlap, soaker hoses, ponding or other approved means. Provide sunshades as necessary. If drying winds inhibit the ability of a given curing method to keep grout moist, erect wind breaks until wind is no longer a problem or curing is finished.

#### **3.04 INSTALLATION - NONSHRINK EPOXY GROUTS**

- A. Mix in accordance with the procedures recommended by the manufacturer. Do not vary the ratio of components or add solvent to change the consistency of the grout mix. Do not overmix. Mix full batches only to maintain proper proportions of resin, hardener and aggregate.
- B. Place grout into the designated areas in a manner which will avoid trapping air. Placement methods shall ensure the filling of all spaces and provide full contact between the grout and adjoining surfaces. Provide grout holes as necessary.
- C. Minimize "shoulder" length (extension of grout horizontally beyond base plate). In no case shall the shoulder length of the grout be greater than the grout thickness.
- D. Finish grout by puddling to cover all aggregate and provide a smooth finish. Break bubbles and smooth the top surface of the grout in conformity with the manufacturer's recommendations.
- E. Epoxy grouts are self-curing and do not require the application of water. Maintain the formed grout within its recommended placement temperature range for at least 24 hours after placing, or longer if recommended by the manufacturer.

### 3.05 INSTALLATION – CONCRETE GROUT

- A. Screed underlying concrete to the grade shown on the Drawings. Provide the surface with a broomed finish, aligned to drain. Protect and keep the surface clean until placement of concrete grout.
- B. Remove the debris and clean the surface by sweeping and vacuuming of all dirt and other foreign materials. Wash the tank slab using a strong jet of water. Flushing of debris into tank drain lines will not be permitted.
- C. Saturate the concrete surface for at least 24 hours prior to placement of the concrete grout. Saturation may be maintained by ponding, by the use of soaker hoses, or by other methods acceptable to the District. Remove excess water just prior to placement of the concrete grout. Place cement slurry immediately ahead of the concrete grout so that the slurry is moist when the grout is placed. Work the slurry over the surface with a broom until it is coated with approximately 1/16 to 1/8 inch thick cement past. (A bonding grout composed of 1 part Portland cement, 1-1/2 parts fine sand, an approved bonding admixture and water, mixed to achieve the consistency of thick paint, may be substituted for the cement slurry.)
- D. Place concrete grout to final grade using the scraper mechanism as a guide for surface elevation and to ensure high and low spots are eliminated. Unless specifically approved by the equipment manufacturer, mechanical scraper mechanisms shall not be used as a finishing machine or screed.

Related drawings: DWD 9

END OF SECTION

## SECTION 15100

### VALVES, HYDRANTS AND APPURTENANCES

#### PART 1 GENERAL

##### 1.01 SUMMARY OF SECTION

- A. Furnish all labor, supervision, materials, equipment and incidentals required and install complete and ready for operation all valves as shown on the Drawings and as specified herein.
- B. Specifications for the following valves and appurtenances are included in this section.
  - 1. Valve Actuators
  - 2. Gate Valves
  - 3. Butterfly Valves
  - 4. Ball Valves
  - 5. Insulating Fittings
  - 6. Fire Hydrants
  - 7. Air Release Valves
  - 8. Blowoffs
  - 9. Piping Specialties
    - a. Dielectric Connectors
    - b. Plugs and Caps
    - c. Miscellaneous Adaptors
    - d. Flexible Connectors
      - i. Flanged Coupling Adapters
      - ii. Mechanical Couplings
    - e. Harnessing and Restraints
    - f. Appurtenances and Miscellaneous Items
    - g. Valve Boxes

h. Tapping Tees, Saddles, and Sleeves

**1.02 SUBMITTALS**

- A. Submittals shall include the following:
  - 1. The manufacturer or supplier.
  - 2. Drawings showing all important details of construction and dimensions.
  - 3. Descriptive literature, bulletins and/or catalogs of the equipment.
  - 4. The total weight of each item.
  - 5. A complete bill of materials.
  - 6. Additional submittal data, where noted with individual pieces of equipment.
- B. Test Reports
  - 1. Provide hydrostatic test data, per manufacturer's standard procedure or MSS-SP-61 for all valve types.
- C. Certificates
  - 1. Submit an affidavit of compliance with the specified standards, including certified results of required tests and certification of proper installation.

**1.03 REFERENCE STANDARDS**

- A. Referenced standards shall be the most recent version or edition.
- B. American Society for Testing and Materials (ASTM)
  - 1. ASTM A126 – Standard Specification for Gray Iron Castings for Valves, Flanges, and Pipe Fittings
  - 2. ASTM A276 – Standard Specification for Stainless Steel Bars and Shapes
- C. American Water Works Association (AWWA)
  - 1. ANSI/AWWA C111/A21.11 – Rubber-Gasket Joints for Ductile-Iron Pressure Pipe and Fittings
  - 2. AWWA C502 – Dry-Barrel Fire Hydrants
  - 3. ANSI/AWWA C504 – Rubber-Seated Butterfly Valves
  - 4. AWWA C542 – Electric Motor Actuators for Valves and Slide Gates

5. AWWA C550 – Protective Interior Coatings for Valves and Hydrants
  6. AWWA C800 – Underground Service Line Valves and Fittings
- D. American National Standards Institute (ANSI)
1. ANSI B2.1 – Specifications, Dimensions, Gauging for Taper and Straight Pipe Threads (except dry seals).
  2. ANSI/ASME B 16.1 – Cast Iron Pipe Flange and Flanged Fittings Class 25, 125, 250 and 800
  3. ANSI/ASME B 16.10 – Face-to-Face and End-to-End Dimensions of Valves
  4. ANSI/NSF 61 – Drinking Water System Components
- E. American Iron and Steel Institute (AISI)
- F. Manufacturer's Standardization Society of the Valve and Fittings Industry (MSS)
1. MSS-SP-61 – Pressure Testing of Steel Valves.
- G. National Electrical Manufacturers Association (NEMA)
- H. Underwriters Laboratories (UL)
- I. Factory Mutual Insurance (FM)

#### **1.04 QUALITY ASSURANCE**

- A. Qualifications
1. Valves and appurtenances shall be products of well established firms who are fully experienced, minimum 10 years, reputable and qualified in the manufacture of the particular equipment to be furnished.
  2. The equipment shall be designed, constructed and installed in accordance with the best practices and methods and shall comply with these Specifications as applicable.
  3. All units of the same type shall be the product of one manufacturer.
- B. Certifications
1. The manufacturers shall furnish an affidavit of compliance with Standards referred to herein as specified in paragraph 1.03C. Refer to Part 4 for testing required for certain items in addition to that required by referenced standards.

2. All products in contact with and potentially in contact with potable water shall be NSF 61 certified.
- C. Inspection of the units may also be made by the District or other representative of the District after delivery. The equipment shall be subject to rejection at any time due to failure to meet any of the Specification requirements, even though submittal data may have been accepted previously. Equipment rejected after delivery shall be marked for identification and shall be removed from the job site at once.

## **1.05 DELIVERY, STORAGE AND HANDLING**

### **A. Packing and Shipping**

1. Care shall be taken in loading, transporting and unloading to prevent injury to the valves, appurtenances, or coatings. Equipment shall not be dropped. All valves and appurtenances shall be examined before installation and no piece shall be installed which is found to be defective. Any damage to the coatings shall be repaired as acceptable to the Construction Manager.
2. Prior to shipping, the ends of all valves shall be acceptably covered to prevent entry of foreign material. Covers shall remain in place until after installation of connecting piping is completed.
  - a. All valves 3 inch and larger shall be shipped and stored on site until time of use with plastic, wood, or plywood covers on each valve end.
  - b. Valves smaller than 3 inch shall be shipped and stored as above except that heavy plastic or cardboard covers may be used on the openings.
  - c. Rising stems and exposed stem valves shall be coated with a protective oil film which shall be maintained until the valve is installed and put into use.
  - d. Any corrosion in evidence at the time of acceptance by the District shall be removed, or the valve shall be removed and replaced.
3. Insofar as is practical, the equipment specified herein, shall be factory assembled. The parts and assemblies that are shipped unassembled, shall be packaged and tagged in a manner that will protect the equipment from damage and facilitate the final assembly in the field.

- B. Weight, handling instructions, type of storage required, and instructions for protective maintenance during storage shall be included with each shipment to the project site.

## **1.06 MAINTENANCE**

- A. Special tools and the manufacturer's standard spare parts, if required for normal operation and maintenance, shall be supplied with the equipment.
- B. Provide all special tools required for normal maintenance. Tools shall be packaged in a steel case, clearly and indelibly marked on the exterior to indicate equipment for which tools are intended.
- C. Provide to the District a list of all spare and replacement parts with location where they are available.

## **PART 2 PRODUCTS**

### **2.01 MATERIALS AND EQUIPMENT - GENERAL**

- A. Valves and appurtenances shall be of the size shown on the Drawings or as noted and as far as possible equipment of the same type shall be identical and from one manufacturer.
- B. Valves and appurtenances shall have the name of the maker, nominal size, flow directional arrows, working pressure for which they are designed and standard referenced, cast in raised letters or indelibly marked upon some appropriate part of the body.
- C. Unless otherwise noted, items shall have a minimum working pressure of 150 psi or be of the same working pressure as the pipe they connect, whichever is higher and suitable for the pressures noted where they are installed.
- D. Joints, size and material - unless otherwise noted or required by the District:
  - 1. Except where noted, all joints referred to herein shall be of the same type, nominal diameter, material and with a minimum rating equal to the pipe or fittings they are connected to.
  - 2. Valves and appurtenances shall be of the same nominal diameter as the pipe or fittings they are connected to.
- E. Provide all special adapters as required to ensure compatibility between valves, appurtenances and adjacent pipe.
- F. Valves and actuators shall be designed for submerged service where water may completely submerge the valve and operator. All other units shall be as a minimum weather tight.
- G. Valve nut extensions shall be Schedule 80 steel. The length (in inches) of the extension shall be arc welded on the top of the circular plate.
- H. Valves shall be wrapped in polyethylene. All steel bolts and nuts shall be coated with bitumastic.



## 2.02 VALVE ACTUATORS

- A. Unless otherwise noted, valves shall be manually actuated. The lever type operators may be supplied on quarter-turn type valves, 2 inches and smaller, if recommended by the valve manufacturer. Buried valves and those with operating nuts shall have a non-rising stem with an AWWA 2 inch nut.
- B. All actuators shall be capable of moving the valve from the full open to full close position and in reverse and holding the valve at any position part way between full open or closed.
- C. Each operating device shall have cast on it the word "OPEN" and an arrow indicating the direction of operation.
- D. Gear Actuators
  - 1. Unless otherwise noted, gear actuators shall be provided for the following: all valves of larger than 8 inch nominal diameter; all buried valves with operating shaft mounted horizontally (butterfly, plug, etc.); where specified and/or indicated on the Drawings; where manual operator effort is greater than 80 ft-lbs rim pull.
  - 2. Gear actuators shall be of the traveling nut type with output shaft perpendicular to valve shaft, having a removable hand wheel mounted on the output shaft. Unless noted, they shall conform to AWWA C504, except with butterfly valves which need not be certified.
  - 3. Actuators shall be capable of being removed from the valve without dismantling the valve or removing the valve from the line.
  - 4. Gearing shall be machine-cut steel designed for smooth operation. Bearings shall be enclosed and permanently lubricated, with bronze bearing bushings provided to take all thrusts and seals and to contain lubricants. Housings shall be sealed to exclude moisture and dirt, allow the reduction mechanisms to operate in lubricant and be of the same material as the valve body.
  - 5. Manual operator input effort to the handwheel shall be a maximum of 40 ft-lbs for operating the valve from full open to full close, under any conditions. Gear actuators shall indicate valve position and have adjustable stops. Maximum handwheel size shall be 24 inch diameter.
- E. All position indication and direction of opening arrows shall be embossed, stamped, engraved, etched or raised decals.
- F. Unless otherwise noted, all valves larger than 3 inch nominal diameter shall be provided with position indicators at the point of operation.

## 2.03 GATE VALVES

- A. Gate valves shall be used for pipe diameters 12 inches or smaller.
- B. Gate valves 4 inches through 12 inches shall conform to AWWA C515, and shall be resilient seated with fully encapsulated disk with nonrising stem, and have O ring stuffing boxes. Stuffing boxes shall be bolted and constructed so as to aid valve repair. Valves shall open counterclockwise and be fitted with 2 inch square operating nuts.
- C. Valve ends shall be flanged, push-on, or mechanical joint, as required by the adjoining pipe material. Gate valves installed on PVC plastic pipelines shall have push-on or flange by push-on ends. Valves with mechanical joint ends shall not be used with PVC plastic pipe except by special permission of the District.
- D. All gate valves 4 inches through 12 inches in size shall be Mueller A2361 with ductile iron body and with 304 stainless steel nuts and bolts for valve bonnet and stuffing box.

## 2.04 BUTTERFLY VALVES

- A. General: Butterfly valves up to 72 inches shall conform to ANSI/AWWA C504 subject to the following requirements. Valves shall be of the size shown. Flanged valves shall be a 150-pound or 250-pound class type valve drilled with a 125-pound bolt pattern and shall be short-bodied. Valve body shall be cast iron or ductile iron. Shaft seals shall be designed for use with standard split-V type packing, or other acceptable seal. The interior passage of butterfly valves shall not have any obstructions or stops. The rubber seat shall be EPDM and shall be positively clamped or bonded into the disc or body of the valve. Cartridge-type seats will not be allowed. All interior ferrous surfaces of valves shall be factory-applied epoxy lined in conformance with AWWA C550. Epoxy interior lining and disc of each valve shall be certified to be holiday free from the factory, with valve serial numbers indicated. Exterior of valves shall be epoxy coated, exclusive of the flange faces; holiday free certification is not required.
- B. Permanently self-lubricating body bushings shall be provided and shall be sized to withstand bearing loads. Stuffing box of liberal dimensions shall be provided at the operator end of the vane shaft. Packing shall be of the self-compensating type. A sealing element utilizing O-rings shall also be acceptable. Packing shall be held in place by a bolted corrosion resistant retainer plate or gland; retainer clips are not acceptable. Replacement of seals, for all size butterfly valves, shall not require removal of the valve from the line.
- C. The valve shaft shall be designed for both torsional and shearing stresses when the valve is operated under its greatest dynamic or seating torque. The extended operating nut shall be secured with a shear pin designed to shear at 300 foot-pounds of torque. No reductions of shaft diameter will be allowed except at the operator connection. Any reduction shall have a full radius fillet.

- D. Valves shall be flanged for in-line applications and flange by mechanical joint for tee or cross applications.
- E. Manual Operators: Operators shall conform to ANSI/AWWA C504, subject to the following requirements. Unless otherwise shown, all unburied manually-operated butterfly valves shall be equipped with a handwheel and position indicator. Buried valves shall be equipped with a 2-inch square operating nut with a nut actuator. All operators shall be side mounted.
- F. Body Stops: The use of a stop or lug cast integrally with or mechanically secured to the body for the purpose of limiting disc travel by means of direct contact or interference with the valve disc (in either the open or closed position) will not be acceptable.
- G. Flanges shall be finished to true plane surfaces within a tolerance limit of 0.005 inches. The finished face shall be normal to the longitudinal valve axis within a maximum angular variation tolerance of 0.002 inch per foot of flange diameter.
- H. Coatings and Linings: All butterfly valve coatings and linings shall be factory applied and holiday free. Manufacturer shall provide a Certificate of Compliance to this effect.
- I. Where mechanical joint ends are specified, either mechanical joint or push-on ends conforming to ANSI/AWWA C111/A21.11 will be acceptable.
- J. Manufacturers: Mueller Lineseal III Class 150B or Mueller Lineseal XP Class 250B, no equal, certified with serial number.

## **2.05 BALL VALVES**

- A. Ball valves shall be three-piece, for use on potable water piping. Maximum operating pressure shall be 150 psig. Actuator shall be manual, lever type.
- B. Materials shall be as follows:
  - 1. Body: Lead Free Brass, ASTM B30-12.
  - 2. Ball: Hard chrome plated brass ball.
  - 3. Stem: Lead Free Brass, ASTM B30-12.
  - 4. Seats: Durafill.
  - 5. Seals: TFE.
  - 6. Bolting: Type 316 stainless steel.
- C. Shall be as manufactured by Watts Series B-6000; Or equal.

## **2.06 INSULATING FITTINGS**

- A. Fittings shall be of type to provide control of electrolysis and equal to "Dielectric" as manufactured by Mueller or equal.

## **2.07 FIRE HYDRANTS**

- A. Fire hydrants shall be wet-barrel type, and shall be Clow 960 (with 1x4½" & 2x2½" connections) or as approved by the Contra Costa County Fire Protection District. The Contra Costa County Fire Protection District shall have final authority in specifying fire hydrant manufacturer, model, outlet configuration, and color.
- B. All fire hydrants shall be mounted to a Clow LBI 400A check valve with break-off spool. The hydrant body shall be mounted to this spool with stainless steel bolts, sized as required.
- C. Ductile iron hydrant bury shall be by Sigma or South Bay.
- D. All fire hydrants shall be painted with two coats of Rust-oleum Rohper 1-GL 2PK V7400 Safety Yellow.

## **2.08 AIR RELEASE VALVES**

- A. Air release valves shall have 1 inch inlet connections. Working parts shall be brass, stainless steel, or other non-corroding material. Valve body and working parts shall be designed for a working pressure of 150 psi. The orifice shall be sized for a working pressure of 80 psi. Floats shall be stainless steel.
- B. Air release valves shall be Crispin Universal UL10.1. Air release valve enclosures shall be Christy N36 with extension. Enclosure lid shall be Placer Waterworks catalog #PW/AE3618-M, with 1"x4" stainless steel name plate engraved with "Diablo Water District Potable Water". Angle valve for ARV – Mueller B-24258. Screens for ARVs shall be Christy 1" FPT #10 or DWD approved equal.

## **2.09 BLOWOFFS**

- A. A 2 inch blowoff assembly shall be installed at the termination of each water main 12 inches and smaller in size, except that a hydrant shall be installed where possible. The blowoff outlet shall be installed at the invert of the end cap.
- B. A 4 inch blowoff assembly shall be installed at the termination of each water main 16 inches and larger in size, except that a hydrant shall be installed where possible. The blowoff outlet shall be installed at the invert of the end cap where possible.
- C. Blowoff piping and valves shall not rest on the trench walls, bottom, or blocking prior to pouring thrust blocks.

- D. Valves for blowoffs shall be Mueller B-24286.

## 2.10 PIPING SPECIALTIES

### A. Dielectric Connectors

1. Dielectric pipe fittings/insulators and unions shall be used to prevent galvanic action wherever valves or piping of dissimilar metals connect. This shall be particularly the case for copper, brass and bronze piping connecting to cast iron or steel piping systems.
2. Dielectric unions shall be used for 2 inch and smaller connections. Steel union nuts shall meet ASTM A575 requirements. The steel or ductile iron connection end shall have a steel body and shall have accurately machined taper tapped pipe threads in accordance with ANSI B2.1. The copper connection end shall be a copper solder joint that meets requirements of ASTM B88. Dielectric unions shall be rated for at least 250 psi at 210 degrees F.
3. Dielectric flange unions shall be used for connections 2-1/2 inches and larger. Cast iron flanges shall meet ASTM A126; the copper solder end shall meet ASTM B62 and the pipe thread shall meet ANSI B2.1. Dielectric flange unions shall be rated for at least 175 psi at 210 degrees F.
4. Dielectric unions and flange unions shall be as manufactured by Epcos Inc., Cleveland, OH or equal.
5. Flange insulating kits shall be as acceptable to the Engineer, as manufactured by PSI or equal.
6. Insulated sleeve couplings and flange adaptors shall be similar to those units as specified elsewhere.

### B. Plugs and Caps

1. Provide standard plug or cap as required for testing; plugs and caps shall be suitable for permanent service.
2. Plug or cap or otherwise cover all piping work in progress.

### C. Miscellaneous Adapters

1. Between different types of pipe and/or fittings special adapters may be required to provide proper connection. Some of these may be indicated on the Drawings or specified with individual types of pipe or equipment. However, it is the Contractor's responsibility to ensure proper connection between various types of pipe, to structures and between pipe and valves, gates, fittings and other appurtenances. The Contractor shall provide all adapters as required, whether specifically noted or not.

2. As required, these adapters shall be suitable for direct bury, with proper dielectric insulation and as a minimum, if metallic (not stainless steel or galvanized), with two coats of Coal Tar Epoxy.

D. Flexible Connectors

1. Flanged Coupling Adapters for plain end pipe at fittings, valves and equipment shall be Dresser Style 127 or 128, similar models by Hymax; Baker or equal. Nuts, bolts and other hardware shall be Type 304 stainless steel as described in Specification Section 15100.
2. Mechanical Couplings shall be rated for a minimum working pressure of 150 psi. The barrel shall be a minimum 10 inches long. Couplings shall be cleaned and shop primed with manufacturer's standard rust inhibitive primer. Mechanical couplings shall be Smith-Blair, Romac, JCM, Hymax or Apac only, with stainless steel nuts, bolts, and threaded rods.

E. Harnessing and Restraints

1. Where harnessed couplings or adapters are noted, they shall conform to AWWA Manual M11 except as modified by the Drawings or this Specification.
2. Unless otherwise noted, size and material for tie rods, clamps, plates and hex nuts shall be as shown on the Drawings, or, if not shown on the Drawings, shall be as required in AWWA Manual M11. Manufactured restraining clamp assemblies shall be as manufactured by Stellar Corporation, Columbus, OH or fabricated equal.
3. Restrained joints (such as welded, locking mechanical joints) shall be of the type specified with the individual type of pipe. If not specified, restrained (locking) mechanical joint pipe shall be of the manufacturers standard design utilizing a locking device (ring or ears) integrally cast with the pipe.
4. For up through 18-in diameter ductile iron pipe only, the following may be used as an alternative to other restraint system:
  - a. The optional mechanical joint restrains shall be incorporated in the design of a follower gland. The gland shall be manufactured of ductile iron conforming to ASTM A536. Dimensions of the gland shall be such that it can be used with the standardized mechanical joint bell and tee-head bolts as specified with the pipe.
  - b. The restraint mechanism shall consist of numerous individually activated gripping surfaces to maximize restraint capability. The gripping surfaces shall be wedges designed to spread the bearing surfaces on the pipe. Twist-off nuts, sized same as tee-head bolts, shall be used to ensure proper actuating of restraining devices. When the nut is sheared off, standard hex nut shall remain.

- c. The mechanical joint restraint device for ductile iron pipe shall have a working pressure of at least 250 psi with a minimum safety factor of 2:1.
- d. The mechanical joint restraint devices shall be of the type listed below or equal.
- e. For Ductile Iron Pipe: EBAA Iron, Inc. Megalug 1100 series.
- f. For PVC: EBAA Iron, Inc. Megalug 2000 series.

F. Appurtenances and Miscellaneous Items

- 1. All gaskets, glands, bolts, nuts and other required hardware shall be provided for connection of piping and appurtenances. Bolts and nuts shall be, 304 stainless steel, with hexagon nut (unless otherwise noted). Bolts shall be marked 'F-593C' or 'F-593D' only. Heads with two slash marks are not to be used. T-bolts shall be used on mechanical joint fittings. All other hardware shall be of the size, type and number as required and recommended by the piping or appurtenance manufacturer and as specified herein. T-bolts shall be as supplied by the manufacturer.
- 2. All gaskets for flanges shall be full face and suitable for 200 degrees F operating temperature, and the fluids carried. Gaskets shall be Garlock Multi-Swell 3760-U, only. Gaskets containing asbestos shall not be permitted. Bolt-ups for flanges shall be 304 stainless steel.
- 3. Plugs, caps and similar accessories shall be of the same material as the pipe and of the locking type, unless otherwise noted.
- 4. Unions shall be of the same material as the pipe, except for dielectric connections.
- 5. Special protective tape shall be 10 mil tape.

G. Valve Boxes

- 1. Valve boxes shall be of suitable rolled steel or concrete construction and not less than 8 inches in diameter. Suitable cast iron traffic frames and covers shall be provided. Covers shall have cast thereon the words "WATER", or as appropriate for the installation. All parts of the traffic frames and covers shall be coated by dipping in bituminous varnish or coal tar. Rolled steel valve boxes shall be completely coated with coal tar enamel before installation. Valve boxes shall be Christy G5 or G12 as required.

## H. Tapping Tees, Saddles, and Sleeves

1. Tapping sleeves up to 24" shall be JCM 432 and 30" sleeves shall be JCM 452. Tapping sleeves over 30" shall be per DWD. All hardware for tapping tees shall be Type 304 stainless steel. In size on size installations, undersize the diameter of the tap by ½-inch. Flanges on stainless steel tees shall be stainless steel. A ¾-inch NPT test plug shall be provided.

## **PART 3      INSTALLATION**

### **3.01    INSTALLATION - GENERAL**

- A. All valves and appurtenances shall be installed per these Specifications, the manufacturer's instructions and approved shop drawings in the locations shown, true to alignment and rigidly supported. Any damage to the above items shall be repaired to the satisfaction of the District before they are installed.
- B. All materials shall be carefully inspected for defects in construction and materials. All debris and foreign material shall be cleaned out of openings, etc. All valve flange covers shall remain in place until connected piping is in place. All operating mechanisms shall be operated to check their proper functioning and all nuts and bolts checked for tightness. Valves and other equipment which do not operate easily, or are otherwise defective, shall be repaired or replaced.
- C. Unless otherwise noted, joints for valves and appurtenances shall be made up utilizing the same procedures as specified under the applicable type connecting pipe joint and all valves and other items shall be installed in the proper position as recommended by the manufacturer. Contractor shall be responsible for verifying manufacturers' torquing requirements for all valves.

### **3.02    INSTALLATION OF MANUAL OPERATIONAL DEVICES**

- A. Unless otherwise noted, all operational devices shall be installed with the units of the factory, as shown on the Drawings or as acceptable to the District to allow accessibility to operate and maintain the item and to prevent interference with other piping, valves and appurtenances.
- B. Valves shall be set plumb, supported against settlement and properly fitted to the adjacent sections of main. All valves shall be operated prior to installation in accordance with the manufacturer's recommendations. Valve interior shall be clean and wet prior to operation.
- C. For manually operated valves 3-inch in diameter and smaller, valve operators and indicators shall be rotated to display toward normal operation locations.
- D. Floor boxes, valve boxes, extension stems and low floor stands shall be installed vertically centered over the operating nut, with couplings as required and the elevation of the box top shall be adjusted to conform with the elevation of the finished floor surface or grade at the completion of the Contract. Boxes and stem



guides shall be adequately supported during concrete pouring to maintain vertical alignment. Valves boxes must not bear on the valve or pipe so that surface traffic loads are not transferred onto pipe.

- E. All hydrants shall stand plumb. Hydrants with pumper nozzles shall have hose nozzles parallel with, and the pumper nozzle perpendicular to, the curb line. Hydrants having hose nozzles 90 degrees apart shall be set so that the line bisecting the angle between the nozzles is perpendicular to the curb line. All hydrants shall be installed with an LB 400 check valve with breakoff spool per manufacturer's recommendations.
- F. Immediately before installation of a hydrant, the following operations shall be performed: (a) the hydrant shall be thoroughly inspected; (b) the hydrant interior shall be thoroughly cleaned; (c) the hydrant shall be opened and closed as many times as may be necessary to determine if all parts are in working order, with valves seating properly; and (d) the packing gland checked to determine if the packing is in place and the gland nut properly tightened.
- G. Air release valves shall be installed to not create a cross connection.
- H. Installation of Pipeline Appurtenances
  - 1. All pipeline appurtenances shall be installed as required and in accordance with the manufacturer's recommendations, as acceptable to the Engineer.
  - 2. Gages, meters and similar in-line items shall be isolated from testing pressures in excess of the rated pressure of the assembly.
  - 3. Use Teflon tape on all screwed fittings.
- I. Installation of Tapping Tees
  - 1. After installation, poly bag tapping tees.

### **3.03 CLEANING**

- A. All items including valve interiors shall be cleaned prior to installation, testing, disinfection, and final acceptance. Disinfection shall be as specified in 02675.

**PART 4 INSPECTION AND TESTING**

**4.01 INSPECTION, TESTING AND CORRECTION OF DEFICIENCIES**

- A. Take care not to over pressure valves or appurtenances during pipe testing. If any unit proves to be defective, it shall be replaced or repaired to the satisfaction of the District.
- B. Tapping tees shall be tested with air at 90 psi for 60 minutes.

Related drawings:    DWD 8                    DWD 19  
                              DWD 9                    DWD 21  
                              DWD 15                  DWD 22  
                              DWD 16  
                              DWD 17  
                              DWD 18

END OF SECTION

## SECTION 15400

### SERVICES AND METER INSTALLATIONS

#### PART 1 GENERAL

##### 1.01 SCOPE OF WORK

- A. This Section specifies the basic piping and service meter materials of each service, including valves. Specific uses and applications are specified in other related Sections.
- B. Furnish all labor, materials, equipment, services and incidentals required and install as shown on the Drawings and as specified herein.
  - 1. Service Piping
  - 2. Meters
  - 3. Meter Boxes
  - 4. Corporation Stops
  - 5. Double Check Valve
  - 6. Reduced Pressure Backflow Preventer
  - 7. Double Check Detector Valves
  - 8. Fire Protection

##### 1.02 SUBMITTALS

- A. Submit, in accordance with this Section, shop drawings and technical literature covering details of all service-meter systems being furnished under this Section prior to fabrication, assembly or shipment.
- B. For units that will be shipped exposed, provide a description of the protective packaging that will be used during transit
- C. All submittals shall contain a statement that Sections 15400 and 15100 have been read and complied with. The certification statement shall be made by all of the following that are applicable; the Contractor, sub-contractor and the vendor. The statement shall be an individual statement for each party involved, and shall be included with every submittal and resubmittal.

### **1.03 REFERENCE STANDARDS**

- A. Referenced standards shall be the most current edition.
- B. American Society for Testing and Materials
  - 1. ASTM B88 – Standard Specification for Seamless Copper Water Tube

### **1.04 QUALITY ASSURANCE**

- A. Inspection by the District's representative or failure to inspect shall not relieve the Contractor of responsibility to provide materials and perform the work in accordance with the documents.
- B. The piping manufacturer shall furnish an affidavit of compliance certifying that all materials used and work performed shall comply with the specified requirements. The Contractor shall provide copies of mill test confirming the type of material used in the various components.

### **1.05 COORDINATION**

- A. The Contractor shall assume full responsibility for coordination of the water service systems, including; scheduling, and verification that all structures, piping and the mounting of equipment are compatible.

## **PART 2 PRODUCTS**

### **2.01 SERVICE PIPING**

- A. Service lines sizes up to 2 inch shall be Type K annealed (soft) copper tubing, polyethylene coated Mueller Streamline and shall conform to ASTM B88. Polyethylene piping shall be used in soil with a corrosion rating of 1 or 2 as required by the District. Service lines above 1 inch shall be Type K annealed (soft) copper tubing in blue poly-wrap.
- B. Double strap service saddles (clamps) shall be used on all service connections as shown on the standard drawings. However, wide band saddles may be used on PVC plastic pipe. Services saddles shall be bronze when used with PVC pipe, and full circle stainless steel with full circle insulating pad, when used with ductile iron or steel pipe. Outlet thread shall be AWWA Standard (cc) thread only. Service saddles shall be Mueller.

## 2.02 METERS

- A. Flow meters in sizes 5/8" through 1" shall be Sensus SR11 Low Lead Water Meter (cubic feet). 5/8" meters shall be embossed with 5/8" on the meter body, with 520M FlexNet MTX Unit.
- B. Flow meters in sizes 1-1/2" through 2" shall be compound meters of model: Sensus Omni C2 meter (cubic feet) with 520M FlexNet MTX Unit (single port per meter).
- C. Flow meters in sizes 3" through 4" shall be compound meters of model: Sensus Omni C2 Meter (cubic feet) with 520M FlexNet MTX Unit (single port per meter).

## 2.03 METER BOXES

- A. Meter boxes, extensions, and covers shall be commercial products. Boxes shall be large enough to allow easy maintenance, testing, and removal or backflow preventers, meters, and valves. Traffic covers may be required as described below under Installation.
  - 1. Meter boxes for 5/8" through 2" meter installations shall be Christy B-12, B-16, or N-30 depending on the service size and as indicated on the standard drawings. Meter boxes for meters less than 1-1/2 inch in size shall have Christy B12P001-F (Flex Net) lids. Lids must have drilled hole for FlexNet 520M Unit.
  - 2. Meter boxes for 3-inch meter installations shall be Christy B-40 with B40-61D galvanized lid.
  - 3. Meter boxes for 4-inch installations shall be Christy B-44 with B44-62D lid.
  - 4. Meter boxes in traffic areas shall be Christy B1730 with galvanized steel lid having drilled holes for the FlexNet 520M Unit.
- B. All angle meter stops shall be designed to allow padlocking in the "off" position. One and 1-1/2 inch and 2 inch angle stops shall be Mueller. Angle meter stops for 5/8 inch meters shall be 1 inch with a 1 inch by 3/4 inch reducing meter bushing. 1 inch angle meter stops shall be Mueller B-24258. 1-1/2 inch through 2 inch angle meter stops shall be Mueller B-24276.

## 2.04 CORPORATION STOPS

- A. All 1-1/2 inch and 2-inch corporation stops shall be of ball valve design. Corporation stops shall be of bronze or brass and shall be designed and manufactured in accordance with AWWA C800. Corporation stops shall be Mueller B-25008N with CC thread only.

## 2.05 BACKFLOW PREVENTION DEVICES

- A. In accordance with its Regulation No. 6, the District shall determine for each service whether a backflow prevention device is required.
- B. Double Check Valve
  - 1. Flow-through (passive purge) fire protection systems will be implemented on all new residential buildings unless prior approval is given by the District for the development to use backflow prevention devices, or similar devices, to protect the potable water main when residential fire protection systems are installed. Refer to DWD General Requirements Section 3.26 for passive purge requirements.
  - 2. If the District pre-approves the use of the double check valve backflow prevention device in new residential buildings, the following requirements will be implemented.
    - a. Double check valves for sizes  $\frac{3}{4}$ -inch through 2 inches shall be Febco LF850U.
    - b. Houses with fire sprinkler systems shall use a 1-inch flow meter with a 1-1/4-inch double check valve.
    - c. Installations shall be made adjacent to the meter in a separate utility box.
    - d.  $\frac{1}{4}$  inch MIP X  $\frac{1}{4}$  inch flare adapter to be installed by the Contractor.
- C. Reduced Pressure Backflow Preventer
  - 1. Shall be required on all irrigation systems, and in other locations as required by the District.
  - 2. Reduced pressure backflow preventers for sizes  $\frac{3}{4}$ -inch through 2-inches shall be Febco LF825YA RP with ball valves. For 5/8-inch lines, use  $\frac{3}{4}$ -inch reduced pressure backflow preventer. Unit shall be installed with brass fittings and without a setter. Install BPGI Guardshack two-piece protective enclosure around unit, hinged, stainless steel with forest green powder coating, or approved equal.
  - 3. Reduced pressure backflow preventers for sizes 2½-inch through 10-inches shall be Febco LF880V N-shape. Unit shall be installed with a setter. Install fence enclosure around unit. Install 4-inch guard posts around perimeter of unit if near traffic areas.

- D. Double Check Detector Valve
  - 1. Shall be required on all fire protection systems, and in other locations as required by the District.
  - 2. Double check detector valve assembly for sizes 2 1/2-inch through 10-inches shall be Febco LF876VST N-shape. Unit shall be installed with a setter. Install fence enclosure around unit. Install 4-inch guard posts around perimeter of unit if near traffic areas.
  - 3. To be supplied with Sensus SR11 Low Lead and FlexNet unit.

## **2.06 FIRE PROTECTION**

- A. All fire protection services shall have a gate valve at the connection to the source water main and the approved double detector check valve assembly, as determined by the District. A protective enclosure shall be installed. Furnish a freeze cover, as provided by Dale's Canvas in El Dorado Hills (916-941-6967), or an approved equal that meets the District's standards.

## **PART 3 EXECUTION**

### **3.01 INSTALLATION OF SERVICES**

- A. Water service line location shall be permanently marked with a "W" stamped into the top of the curb where the service line crosses beneath the curb.
- B. Service lines shall rest on undisturbed earth in the bottom of the trench with a 24-inch minimum cover (between) service line and gutter flow line.
- C. The standards described in Division 2 of this document concerning quality of backfill material, backfill operations, backfill placement, and compaction requirements shall also apply to the installation of service lines.
- D. One-inch copper lines shall be provided with a 6-inch minimum offset, "gooseneck," at the corporation stop.
- E. All plastic service piping if approved by the District shall be installed with insulated 12 gage copper wire spiraled around the service line and extended into the meter box. Plastic service piping shall be "snaked" in the trench as recommended by the material manufacturer.
- F. The Contractor, after submittals have been approved, shall physically display to the District's representative the exact type of saddle, corporation stop, service piping, angle meter stop, and appurtenances he intends to install prior to making any actual installation of these items.
  - 1. Contractor to check materials prior to asking for material inspection by District.

- G. PVC plastic pipe shall be tapped for service connections with PVC shell cutter only. Twist or hole drills shall not be used. All tapping shall be done with hand operated drilling machines throughout the corporation stop and saddle. Drilling machines shall be Mueller PL-2, Ford Model 77, or equal, with a controlled feed rate. Electric or air drills shall not be used to avoid cracking and stressing of the pipe.
- H. Soldering of copper tubing will not be allowed.

### **3.02 INSTALLATION OF METER BOXES**

- A. Meter boxes shall not be installed in vehicle traffic areas of driveways except where unavoidable.
- B. Use traffic rated boxes, hot dipped galvanized lids, and collar when in areas to receive traffic loads. Traffic rated lids to be drilled to accept 520M Flex Net unit.

### **3.03 FIELD TESTING**

- A. Provide all air and water necessary for testing the piping systems. Provide all connections for testing under this Section. Remove all debris resulting from testing.
- B. Provide all apparatus and all other supplies or materials which may be necessary for testing the systems and operating the apparatus during the period while tests of any kind are being made, or for carrying out the work of the Contract.
- C. The various piping systems shall be subjected to water or air tests as noted and shall hold tight at pressures stated without extra pumping or water addition for the time intervals stated.
- D. All copper services requiring cathodic protection anodes must be tested prior to acceptance.
- E. All additional tests, methods or materials that may be required by the local ordinances and not specifically specified herein, shall be made as directed by the District or the local inspection authority.
- F. Provide for all repeated tests as necessary to make systems tight as required.
- G. Test water piping as follows:
  - 1. Test all service water connections and piping along with the distribution piping. Testing will be performed to a water pressure of 150 psi at the lowest point in the system being tested. Maintain this pressure without additional pumping for 4 hours without leakage.



### 3.04 CLEANING

- A. At the completion of the work, clean all piping, fixtures, equipment, apparatus and exposed trim for same included in this Section and, where required, polish ready for use.
- B. Thoroughly disinfect the entire potable water distribution systems with a solution of not less than 50 ppm of available chlorine. Allow the disinfecting solution to remain in the system for a minimum period of 24 hours after which time, open all valves and faucets and flush the system with clean water until the residual chlorine content matches the line concentration. Another 24 hours shall be allowed to pass before the sample is taken.

Related drawings: DWD 8  
DWD 9  
DWD 10  
DWD 11  
DWD 12  
DWD 13

END OF SECTION

## SECTION 16640

### CORROSION CONTROL REQUIREMENTS

#### PART 1 GENERAL

##### 1.01 SUMMARY

- A. Section Includes: Soil corrosivity evaluation methods, corrosion control requirements for new water pipelines and laterals, and the furnishing of all labor, materials, services, and equipment for the installation and testing of corrosion control systems.

##### 1.02 REFERENCES

A. APHA/AWWA/WEF SM4500	Standard Methods for the Examination of Water and Wastewater. 2001 Supplement to the 20th Edition: Section 4500
B. ASTM B418	Standard Specification for Cast and Wrought Galvanic Zinc Anodes
C. ASTM D1125	Standard Test Methods for Electrical Conductivity and Resistivity of Water
D. ASTM D1498	Standard Practice for Oxidation-Reduction Potential of Water
E. ASTM D2976	Standard Test Method for pH of Peat Materials
F. ASTM D4327	Standard Test Method for (Chloride) Anions in Water by Suppressed Ion Chromatography
G. ASTM D4327	Standard Test Method for (Sulfate) Anions in Water by Suppressed Ion Chromatography
H. ASTM D4972	Standard Test Method for pH of Soils
I. ASTM G51	Standard Test Method for Measuring pH of Soil for Use in Corrosion Testing
J. ASTM G57	Standard Test Method for Field Measurement of Soil Resistivity Using the Wenner Four-Electrode Method
J. CALTRANS 417	Soils and Waters for Sulfate Content
K. CALTRANS 422	Testing Soils and Waters for Chloride Content
L. CALTRANS 643	Estimating the Service Life of Metal Culverts
M. NACE SP0169	Standard Specification for Control of External Corrosion on Underground or Submerged Metallic Piping Systems

### 1.03 SOIL CORROSIVITY INVESTIGATION

- A. General - In order to determine what corrosion control measures are required for a buried pipeline, a soil investigation shall be performed before the pipeline is installed. The following table, Table 1.03-A, indicates the soil investigation that must be performed for each pipeline project.

**Table 1.03-A  
SOIL INVESTIGATION REQUIREMENTS**

<b>PIPE TYPE</b>	<b>SOIL CORROSIVITY INVESTIGATION</b>
Steel and Ductile Iron	In-situ soil resistivities at 500 ft. intervals and soil chemical analysis at 1000 ft. intervals.
Mortar Coated and Concrete Cylinder	In-situ soil resistivities at 500 ft. intervals and soil chemical analysis at 1000 ft. intervals
Non-Metallic Pipe with Metallic Fittings	In-situ soil resistivities at 500 ft. intervals and soil chemical analysis at 1000 ft. intervals

#### B. Soil Resistivity Measurements

##### 1. Definition of Soil Resistivity

- a. Resistivity is the electrical resistance of a unit volume of a material, the reciprocal of conductivity. Resistivity measurements indicate the relative ability of a medium to carry electrical currents. When a metallic structure is immersed in a conductive medium, the ability of the medium to conduct current will influence the magnitude of galvanic and cathodic protection currents.

##### 2. Methods

- a. The two basic methods of performing soil resistivity shall be either the Wenner 4-Pin method (Standard Drawing DWD C1) or the Soil Box method (Standard Drawing DWD C3). Both tests shall be performed in accordance with ASTM G57 standard. At a minimum, in-situ resistivity measurements shall be conducted with pin spacings of 2.5 feet, 5.0 feet, 7.5 feet, 10 feet, and 15 feet. The soil resistivity measurements and their locations shall be tabulated.

##### 3. Recording

- a. The test results shall be tabulated and submitted to DWD for review. Typical data sheet is provided in Tables 1.03-B3A, 1.03-B3B and 1.03-B3C.

**Table 1.03-B3A  
DIABLO WATER DISTRICT  
In-Situ Soil Resistivities  
Wenner 4-Pin Method**

Pipeline Location: \_\_\_\_\_ Sheet \_\_\_\_\_ of \_\_\_\_\_

Pipe Size: \_\_\_\_\_ Date: \_\_\_\_\_

Depth to Bottom of Pipe: \_\_\_\_\_ By: \_\_\_\_\_

TEST NO.	SAMPLE DEPTH ('D' FT.)	LOCATION	PIN SPACING ('D' FT.) [D]	RESISTANCE (OHM) [R]	RESISTIVITY (OHM-CM) [D]x[R]x191.5	CORROSION RATING

Resistivity Range (ohm-cm)	Corrosion Rating
0 - 500	1
501 - 2,000	2
2,001 - 8,000	3
8,001 - 32,000	4
>32,000	5

**Table 1.03-B3B  
DIABLO WATER DISTRICT  
In-Situ Soil Resistivities  
Wenner 4-Pin Method**

Pipeline Location: \_\_\_\_\_

Sheet \_\_\_\_\_ of \_\_\_\_\_

Pipe Size: \_\_\_\_\_

Date: \_\_\_\_\_

Depth to Bottom of Pipe: \_\_\_\_\_

By: \_\_\_\_\_

TEST NO.	LOCATION	PIN SPACING ('D' Feet) [D]	RESISTANCE DATA FROM METER (Ohm) [R]					SOIL RESISTIVITY (ohm-cm) $\rho = [D] \times [R] \times 19.5$					BARNES LAYER ANALYSIS (ohm-cm) $= 191.5 \times (\text{depth}_b - \text{depth}_a) \times (1 / (1/[R_b] - 1/[R_a]))$				
			2.5	5	7.5	10	15	2.5	5	7.5	10	15	0-2.5'	2.5-5'	5-7.5'	7.5-10'	10-15'

Resistivity Range (ohm-cm)	Corrosion Rating
0 - 500	1
501 - 2,000	2
2,001 - 8,000	3
8,001 - 32,000	4
>32,000	5

**Table 1.03-B3C  
 DIABLO WATER DISTRICT  
 Soil Resistivities  
 Soil Box Method**

**Pipeline Location:** \_\_\_\_\_ **Sheet** \_\_\_\_\_ **of** \_\_\_\_\_

**Pipe Size:** \_\_\_\_\_ **Date:** \_\_\_\_\_

**Depth to Bottom of Pipe:** \_\_\_\_\_ **By:** \_\_\_\_\_

TEST NO.	LOCATION	SAMPLE DEPTH (FEET)	RESISTIVITY (OHM-CM)	CORROSION RATING

Resistivity Range (ohm-cm)	Corrosion Rating
0 - 500	1
501 – 2,000	2
2,001 – 8,000	3
8,001 – 32,000	4
>32,000	5

C. Soil Corrosion Rating

1. The corrosion control requirements for a particular pipeline, valve or fitting depends on the soil corrosion rating. Table 1.03-C1 provides the corrosion rating and corresponding corrosion classification based on soil resistivity.

**Table 1.03-C1  
CORROSION RATING AND CLASSIFICATION**

RESISTIVITY (OHM-CM)	CORROSION RATING	CORROSION CLASSIFICATION
0 - 500	1	Extremely Corrosive
501 - 2,000	2	Corrosive
2,001 - 8,000	3	Moderately Corrosive
8,001 - 32,000	4	Mildly Corrosive
> 32,000	5	Negligibly Corrosive

- D. Soil Chemical Analysis: Corrosion control requirements for mortar coated steel and concrete cylinder pipe depends on the pH, chlorides, and sulfates found in the soil in addition to the soil resistivity. Additional corrosion ratings for mortar coated steel and concrete cylinder pipe based on soil chemistry parameters are provided below.

1. Chlorides: If chlorides of 300 parts per million (ppm) or higher are found in the soil, it shall be given a corrosion rating of 1.
2. Sulfates: If water soluble sulfate in soil samples exceeds 2,000 ppm and/or sulfate in water samples exceeds 1,500 ppm, the soil shall be given a corrosion rating of 1.
3. pH: If soils with a pH of less than 5.0 are found, the soil shall be given a corrosion rating of 1.

E. Laboratory Evaluation

1. Soil samples shall be tested by an approved soils testing laboratory for pH, chlorides, resistivity (100% saturation), sulfates and sulfides using ASTM or CALTRANS test methods as detailed in Table 1.03-E1. The preparation of the soil sample for corrosion evaluation shall be in accordance with the applicable specification.

**Table 1.03-E1  
Soil Laboratory Analysis**

	ASTM Method	CALTRANS Method
Chlorides	D4327	422
pH	D2976/D4972/G51	643
Resistivity (Saturated)	D1125	-
Sulfate	D4327 (SM 4500)	417
Redox Potential	D1498	-

2. Recording

- a. The test results shall be tabulated and submitted to DWD for review. A typical data sheet is provided in Tables 1.03-E2A.

**Table 1.03-E2A  
DIABLO WATER DISTRICT  
Soil Chemical Analysis**

Laboratory Name: \_\_\_\_\_

Pipeline Location: \_\_\_\_\_ Sheet \_\_\_\_\_ of \_\_\_\_\_

Pipe Size: \_\_\_\_\_ Date: \_\_\_\_\_

Depth to Bottom of Pipe: \_\_\_\_\_ By: \_\_\_\_\_

TEST NO.	SAMPLE DEPTH (FEET)	LOCATION	RESISTIVITY [100% Saturation] (ohm-cm)	pH	SULFATES (ppm)	CHLORIDES (ppm)	REDOX POTENTIAL	RATING 1	
								Yes	No

Corrosion Rating 1 Equals:  
 Resistivity 0 to 500 ohm-cm  
 pH < 5.5  
 Sulfate ≥ 2000 ppm (soil sample)  
 ≥ 1500 ppm (water sample)  
 Chlorides ≥ 300 ppm



## 1.04 CORROSION CONTROL REQUIREMENTS

- A. General - The external corrosion control requirements for various types of pipe are based on the soils corrosion rating as provided in Table 103-C1.
- B. New Water Mains & Extensions:
  - 1. Steel, Ductile Iron, Mortar Coated Steel and Concrete Cylinder Pipe - Each new main extension, of any length, from an existing metallic main, shall be electrically isolated from the existing main via an isolation flange or joint. This requirement may be altered by DWD at their sole discretion. The requirements for corrosion control shall be as specified in Table 1.04-E3. If cathodic protection is required, it shall be designed by a Corrosion Engineer as specified in paragraph 1.05.
  - 2. Non-metallic Pipe - Extensions which are constructed out of non-metallic piping material, and which utilize metallic fittings shall be provided with corrosion control as specified in Table 1.04-E3 and paragraph 1.05-A.
- C. Test Station Spacing - Test stations shall be spaced at 1000 ft. maximum intervals for all major metallic transmission and distribution metallic pipelines as directed by DWD Engineer or Corrosion Engineer. In addition, test stations may be required at the starting point and ending point for each new pipeline or extensions to existing pipelines, at crossings with foreign metallic pipelines, at cased crossings and at buried insulating flanges.
- D. Copper Service Laterals - Copper service laterals shall be electrically isolated from metallic water mains via an isolation fitting placed at the corporation stop. If copper piping is used to connect the water meter to the building or residence, the copper lateral shall also be isolated at the water meter. For soil types rated as 1 or 2, polyethylene encasement and galvanic cathodic protection shall be implemented as shown in Table 1.04-E3.
- E. Non-Metallic Pipe with Metallic Fittings and Valves - Types of anodes and required anode sizes for various types of fittings based on soil resistivity are as presented in Tables 1.04-E1 and 1.04-E2. These tables contain the minimum weights for the bare anodes which does not include the weight of the anode backfill material.

**Table 1.04-E1  
Required Zinc Anode Sizes  
Soil Resistivity < 1000 ohm-cm**

Pipe Size (inches)	Valve (lb.)	Cross (lb.)	Tee (lb.)	Elbow (lb.)	Valve plus Fitting*	Fire Hydrant**	Fire Hydrant plus Tee and Valve (lb.)
4	5	5	5	5	5	5	12
6	5	5	5	5	5	12	12
8	5	5	5	5	12	12	12
10	5	5	5	5	12	12	18
12	5	5	5	5	12	12	18

\* Cross, Tee or Elbow

\*\* Includes Elbow plus Riser

**Table 1.04-E2  
Required Magnesium Anode Sizes  
Soil Resistivity > 1000 ohm-cm**

Pipe Size (inches)	Valve (lb.)	Cross (lb.)	Tee (lb.)	Elbow (lb.)	Valve plus Fitting*	Fire Hydrant**	Fire Hydrant plus Tee and Valve (lb.)
4	9	9	9	9	9	9	9
6	9	9	9	9	9	9	9
8	9	9	9	9	9	9	9
10	9	9	9	9	9	9	17
12	9	9	9	9	9	9	17

\* Cross, Tee or Elbow

\*\* Includes Elbow plus Riser

**Table 1.04-E3  
CORROSION CONTROL REQUIREMENTS**

PIPE MATERIAL	Soil Resistivity (ohm-cm)			
	0 - 500 Rating 1	501 - 2,000 Rating 2	2,001 - 8,000 Rating 3	Greater Than 8,000 Rating 4&5
Steel and Ductile Iron Pipe	1. Bonded Coating or Polybag 2. Joint Bonding 3. Test Stations 4. Cathodic Protection 5. Electrical Isolation 6. High Resistance Backfill	1. Bonded Coating or Polybag 2. Joint Bonding 3. Test Stations 4. Cathodic Protection 5. Electrical Isolation 6. High Resistance Backfill	1. Polybag Coating 2. Joint Bonding 3. Test Stations 4. Cathodic Protection 5. Electrical Isolation 6. High Resistance Backfill	1. Polybag Coating 2. Joint Bonding 3. Test Stations 4. Electrical Isolation 5. High Resistance Backfill
Mortar Coated Steel and Concrete Cylinder Pipe	1. Joint Bonding 2. Test Stations 3. Cathodic Protection 4. Electrical Isolation	1. Joint Bonding 2. Test Stations 3. Cathodic Protection 4. Electrical Isolation	1. Joint Bonding 2. Test Stations 3. Electrical Isolation	1. Joint Bonding 2. Test Stations 3. Electrical Isolation
Metallic Valves and Fittings	1. Fusion Bonded Epoxy Coating 2. Cathodic Protection 3. Bitumastic Bolts	1. Fusion Bonded Epoxy Coating 2. Cathodic Protection 3. Bitumastic Bolts	1. Standard Coating 2. Cathodic Protection 3. Bitumastic Bolts	1. Standard Coating 2. Bitumastic Bolts
Copper Piping	1. Isolation From Ferrous Piping 2. Polyethylene encasement* 3. Cathodic Protection	1. Isolation From Ferrous Piping 2. Polyethylene encasement* 3. Cathodic Protection	1. Isolate From Ferrous Piping 2. Polyethylene encasement*	1. Isolate From Ferrous Piping
Repair Clamps	1. Stainless Steel 2. Cathodic Protection	1. Stainless Steel 2. Cathodic Protection	1. Stainless Steel	1. Stainless Steel

\* An extruded bonded coating may be used in lieu of the polyethylene encasement.

## **1.05 DESIGN**

- A. Cathodic Protection System Design - Cathodic protection system designs for distribution and transmission pipelines will be performed and stamped by a qualified Corrosion Engineer. This person shall be responsible for the design, supervision, inspection and testing of the cathodic protection system. Corrosion Engineer refers to a person who is either a licensed Professional Corrosion Engineer in the state of California or certified as a "Cathodic Protection Specialist" by the National Association of Corrosion Engineers (NACE). The qualifications for the Corrosion Engineer shall be submitted to DWD for approval prior to commencement of the design work.

## **PART 2 PRODUCTS**

### **2.01 GENERAL**

- A. Materials and workmanship shall be in accordance with all applicable state and local codes. The use of a manufacturer's name and model or catalog number is only for the purpose of establishing the standard of quality and general configuration desired. Products of other manufacturers will be considered.

### **2.02 JOINT BOND WIRES**

- A. Joint bond wires shall be single-conductor, stranded copper wire with 600-volt HMWPE insulation. Supply all joint bonds complete with a formed copper sleeve on each end of the wire.
  1. Push-on, Mechanical, Ball or Flanged Joints--No.4 AWG wires, 18 inches long.
  2. Flexible Coupling Joints--No.4 AWG wires, 24 inches long, with two 12-inch long insulated No. 4 AWG wire pigtailed.
  3. Insulated Flexible Coupling Joints--No. 4 AWG wire, 18-inch long, with one 12-inch long No.4 AWG wire pigtail.
  4. Concrete Cylinder Pipe--Joint bonds shall be supplied by the manufacturer and shall include the following:
    - a. Shop manufactured rod-cable-rod bonding cable as shown in the details. Rods shall be welded to the bell-and-spigot on opposite sides of the pipe at the spring line of the pipe.
    - b. Bond wire size to be calculated for each joint. Total resistance of the bond or bonds at each joint shall not be greater than 120 percent of the linear resistance of a pipe section.
  5. No. 8 AWG/HMWPE cables may be used to bond joints when galvanic anode systems are utilized, and to bond metallic fittings on nonmetallic piping systems.

## 2.03 GALVANIC ANODES:

- A. High Potential Magnesium Alloy: (Soil resistivities > 1000 ohm-cm)  
Composition:

Aluminum	0.010% Max
Manganese	0.5 to 1.30%
Zinc	0
Silicon	0
Copper	0.02% Max
Nickel	0.001% Max
Iron	0.03% Max
Total Others	0.05% each or 0.3% Max Total
Magnesium	Remainder

- B. Zinc Anodes (ASTM B418, Type II): (Soil resistivities < 1000 ohm-cm)  
Composition:

Iron	0.0014% Max
Cadmium	0.003% Max
Aluminum	0.005% Max
Lead	0.003% Max
Copper	0.002% Max
Zinc	Remainder

- C. Furnish a laboratory analysis guaranteeing that all anodes supplied meet all the requirements of this Specification.
- D. Supply each anode with No. 12 AWG solid copper wire with THHN insulation, 10-feet long.
- E. Silver braze the wire to a galvanized steel rod or strap which is cast into the anode. Seal this connection completely with electrical potting compound. The anode connection shall be stronger than the wire.
- F. Anode Backfill Composition:

Ground Hydrated Gypsum	75 percent
Powdered Wyoming Bentonite	20 percent
Anhydrous Sodium Sulfate	5 percent

- G. Anode Backfill

1. Anode backfill shall have a grain size so that 100 percent is capable of passing through a 20-mesh screen and 50 percent will be retained by a 100-mesh screen. The backfill mixture shall be thoroughly mixed and firmly packaged around the galvanic anode within the cloth bag by means of adequate vibration. Provide anode packaged in a plastic or heavy paper bag of sufficient thickness to protect the anode, backfill, and cloth bag during normal shipping and handling.

## **2.04 CATHODIC PROTECTION TEST STATIONS**

- A. Flush mounted test boxes shall have a concrete body cast with a cast iron ring, with a minimum weight of 55 pounds and minimum dimensions of 8-inch inside diameter and 12-inch length. Brooks Type 1RT Traffic Box, or approved equal. Provide with a 12-pound cast iron lid with the words "CP-Test" cast into the lid.
- B. Terminal boxes shall be high-impact molded Lexan plastic, Model "Big Fink" as manufactured by Cott manufacturing Company or approved equal. The test box shall be provided with sufficient terminals for each cable. Provide terminal block with nickel-plated brass studs, washers, and lock washers.

## **2.05 TEST STATION WIRE**

- A. Wire shall be single conductor, No. 10 AWG stranded copper with 600-volt TW, THWN, or THHN insulation and single-conductor, No. 8 AWG stranded copper with 600-volt TW, THWN, or THHN insulation.

## **2.06 PERMANENT REFERENCE ELECTRODES**

- A. Prepackaged Reference Electrodes
  - 1. Prepackaged Copper-Copper Sulfate Reference Electrode
  - 2. Prepackaged Zinc Reference Electrode
    - a. Material: ASTM B418, Type II.
    - b. Dimensions: 1.4 inches by 1.4 inches by 9 inches.
- B. Wire: No. 12 AWG stranded copper wire with yellow, 600-volt TW, THWN, or THHN insulation. The wire shall be a minimum of 25 feet long and attached to the electrode core by the manufacturer's standard connection. Connection shall be stronger than the wire.
- C. Backfill: 50 percent gypsum, 50 percent bentonite, in a permeable cloth bag, or approved equivalent.
- D. Packaging: Provide electrode packaged in a plastic or heavy paper bag of sufficient thickness to protect the electrode, backfill, and cloth bag during normal shipping and handling.

## **2.07 SHUNTS**

- A. Anode metering shunts shall be 0.01 ohm, 6 amp capacity with 1% accuracy.

## **2.08 EXOTHERMIC WELD MATERIALS**

- A. Exothermic weld materials shall consist of wire sleeves, welders, and weld cartridges according to the weld manufacturer's recommendations for each wire size and pipe or fitting size and material. All welding materials and equipment shall be the product of a single manufacturer such as "Cadweld" by Erico Products, Inc., "Thermoweld" by Continental Industries, Inc., or approved equal. Each cable shall be fitted with a copper sleeve for accomplishing the weld. Interchanging materials of different manufacturers is not acceptable.

## **2.09 GROUND CLAMP**

- A. Ground clamp shall be sized to fit the copper tubing and wire size, made out of high copper alloy, and rated for direct burial.

## **2.10 EXOTHERMIC WELD CAPS**

- A. Coating material for cable-to-pipe connections shall be Handicaps as manufactured by Royston Products or Propoxy 20 epoxy putty as manufactured by the Hercules Chemical Company or approved equal.

## **2.11 WIRE CONNECTORS**

- A. One-piece, tin-plated crimp-on ring connector.

## **2.12 INSULATED JOINTS**

- A. Insulating joints shall be dielectric unions, flanges, or couplings. The complete assembly shall have an ANSI rating equal to or higher than that of the joint and pipeline. All materials shall be resistant to the intended exposure, operating temperatures, and products in the pipeline.
  1. Gaskets--1/8" thick full-faced neoprene faced phenolic.
  2. Insulating Sleeves--Full-length 1/32" thick Grade G-10 fiberglass epoxy.
  3. Insulating Washers--5/32" thick Grade G-10 fiberglass epoxy.
  4. Washers--Same material as bolts, 1/8-inch thick.

## **2.13 CASING INSULATORS**

- A. Casing insulators shall be molded high-density polyethylene with plastic runners and shall consist of bolted segments, complete with stainless steel bolts for assembly.

## **2.14 CASING SEALS**

- A. Casing seals shall be flexible molded rubber seals and shall be supplied complete with two stainless bands for sealing. Split seals are not acceptable.

## 2.15 WALL SEALS

- A. Wall seals shall be interlocking links of molded synthetic rubber. The links are to be connected together with stainless steel bolts. The wall seal shall be sized for the pipe size and type and the wall hole.

## 2.16 PIPE BACKFILL

- A. Imported backfill placed around the pipes shall be a good quality sand backfill with a minimum resistivity greater than 5,000 ohm-cm, a minimum pH greater than 6.0, a maximum chloride concentration less than 300 ppm and a maximum sulfate concentration less than 1,000 ppm.

## 2.17 COATINGS FOR BURIED INSULATING FLANGES

- A. Coat buried insulating flanges with Trenton Wax Tape#1 by The Trenton Corporation or approved equal.

## 2.18 CABLE WARNING TAPE

- A. Cable warning tape shall be 4 inches wide and shall be yellow with black lettering with the legend "CAUTION, CATHODIC PROTECTION CABLES BURIED BELOW" in 3 inches high lettering printed at a minimum of seven foot intervals along the entire buried length of the cable.

## PART 3 EXECUTION

### 3.01 GENERAL

- A. Installation of the specified corrosion control materials shall conform to the guidelines as set forth herein. Any changes in design or method of installation of any item as specified shall be reviewed and approved by DWD Engineer prior to installation.

### 3.02 PIPE JOINT BONDING

- A. Bond all buried non-welded, rubber gasket joints, mechanical joints and fusion-bonded epoxy coated flanges for continuity. Install one or two joint bond wire assemblies at each joint that requires bonding, in accordance with Table 1.04-E3, of this document and the following:

Pipe Size	No. Of Bond Wires Required
Smaller than 20-in diameter	1
20-inch diameter & larger	2

- B. The electrical connection of all wires to pipes and fittings shall be performed using the exothermic welding process.



### **3.03 EXOTHERMIC WELDS**

- A. Exothermic weld connections shall be installed in accordance with Standard Drawing DWD-C6. Coating materials shall be removed from the surface over an area just sufficient to allow proper searing of the graphite weld mold to the pipe surface. The coating shall be entirely removed in the area of the actual weld by using a sanding wheel or metal file. White metal shall be achieved free from resin films. After the weld is complete, strike the weld with a hammer using a moderate amount of force. Welds that dislodge from the pipe surface shall be replaced. Care shall be taken to prevent damage to the wires. All rough edges of the weld and slag shall be removed during this structural test. Spray primer on all bare metal. Cover connection and exposed structure surface with a plastic cap and bitumastic.

### **3.04 ANODE STORAGE AND HANDLING**

- A. Store all prepackaged anodes off the ground and keep them dry at all times. Protect them against weather, condensation, and mechanical damage. Immediately remove all wet or mechanically damaged prepackaged anodes from the site. Prepackaged anodes shall be handled with care to prevent loss of backfill material. Anodes shall not be lifted or installed by the lead wire.

### **3.05 GALVANIC ANODE INSTALLATION**

- A. Remove the plastic or heavy paper bag used for shipping. The cloth bag shall remain around the anode. Care shall be exercised during installation to prevent damage to the cloth bag and loss of backfill material. After placing anodes in the trench, native soil, free of rocks and other foreign objects shall be placed around the anode to a minimum cover of one foot above the anode. Anode shall then be flooded with 5 gallons of fresh water. The remainder to the trench shall then be backfilled with native soil. Install galvanic anodes 1 foot below the pipe invert and at a minimum distance of 3 feet from the pipeline, valve or fitting. Provide a minimum anode spacing of 5 feet from other unprotected pipelines. Install anodes at intervals determined by the cathodic protection design.

#### **B. Anode Location**

- 1. Location of anodes shall be determined by cathodic protection design.

#### **C. Valves and Fittings for Non-metallic Pipe**

- 1. Each buried ductile/cast iron and steel fitting, and valve used in conjunction with nonmetallic pipe shall be cathodically protected with zinc anodes (soil resistivity < 1000 ohm-cm) or magnesium anodes (soil resistivity  $\geq$  1000 ohm-cm). Where two or more metallic fittings are adjacent to each other, they can be bonded together for the purposes of cathodic protection as shown on the Standard Drawings.
- 2. Anode connections to ductile/cast iron and steel fittings and valves shall be made by the exothermic weld method. Any damage to the interior coating shall be repaired in accordance with the manufacturer's recommendations.

### **3.06 WIRES**

- A. Provide a minimum cover of 30 inches over all cables. Use care during installation to avoid punctures, cuts and similar damage to the insulation. Replace entire cable run where any damage to insulation occurs. Cable warning tape shall be placed a minimum of 6 inches above any buried cables.

### **3.07 TEST STATION INSTALLATION**

- A. Test stations shall be installed as shown on the Standard Drawings. A concrete collar shall be set flush with the top of curb or finish grade in paved areas and two inches above grade in landscaped areas. The terminal end of each cable shall be identified with permanent cable markers as shown in the Standard Drawings. The locations for the test stations shall be as specified in the cathodic protection design.
- B. Provide a minimum of 18 inches of slack for each cable in each test station. Sufficient slack shall be provided to allow removal of the terminal box from the test station without disconnecting any of the cables.

### **3.08 INSULATING FLANGED JOINTS**

- A. All insulating components of the insulating flanged gasket set shall be cleaned of all dirt, grease oil and other foreign materials immediately prior to assembly. Bolt holes in mating flanges shall be properly aligned at the time bolts and insulating sleeves are inserted to prevent damage to the insulation. After flanged bolts have been tightened, each insulating washer shall be inspected for cracks or other damage. All damaged washers shall be replaced. After assembly, resistance between each bolt and flange shall be measured with an approved ohmmeter and the minimum resistance shall be 50,000 ohms. Where the insulating joint is assembled in the shop and shipped as a unit, resistance shall be measured in the shop between the flanges and between each bolt and flange and shall meet the above requirements. All below grade insulating joints shall be coated as specified above.

### **3.09 COATING BURIED INSULATING FLANGED JOINTS**

- A. Surfaces shall be cleaned of all dirt, grease, oil and other foreign materials immediately prior to coating. Remove loose rust, paint and other foreign matter in accordance with SSPC SP2 or SP3. A prime coating shall be applied in a uniform coating over the entire surface to be wrapped. A liberal coating shall be applied to threads, cavities, shoulders, pits and other irregularities. A fill coating shall be molded and packed onto irregular surfaces such as flanges, valves or flexible couplings to create a smooth profile prior to wrapping. A wrap coating shall be spiral wrapped using a minimum of 55 percent overlap to ensure a double thickness of material. At the completion of each roll the overlaps shall be smoothed by hand in the direction of the spiral to ensure sealing of the overlap. A 2- inch overlap shall be maintained when overlapping one roll with the end of a new roll. Overlap shall occur on the top half of the pipeline. A guard coating shall be spiral over-wrapped using a 55 percent overlap to ensure a double coating.

### **3.10 CASING INSULATOR AND SEALS**

- A. At all locations where water system piping is cased with metal casing, casing insulators and end seals shall be installed. Type and spacing of insulators required shall be at manufacturer's written recommendations and depend on type and size of casing and carrier pipe.

### **3.11 CABLE WARNING TAPE**

- A. All buried anodes and cables that are not within 3 feet of the piping, shall have plastic warning tape installed a minimum of 12 inches above the top of the cables or anodes for the entire buried length of the cables or anode beds.

### **3.12 TESTING**

- A. The Contractor shall furnish all necessary equipment, material, and qualified personnel required to perform all tests described herein.
- B. Electrical Continuity Testing
  - 1. Conduct continuity testing on all buried joints that are required to be bonded both before backfilling and after backfilling.
  - 2. Before Backfilling
    - a. The Contractor shall test electrical continuity of completed joint bonds before backfilling using a digital low resistance meter.
  - 3. Test Procedure Before Backfilling
    - a. Measure the resistance of joint bonds with the low resistance ohmmeter in accordance with the manufacturer's written instructions. Use the helical hand spikes to contact the pipe on each side of the joint without touching the exothermic weld or the bond. The contact area shall be cleaned to bright metal by filing or grinding and be without any surface rusting or oxidation.
  - 4. Record Keeping Before Backfilling
    - a. Records shall be made of each bonded pipeline during the test and submitted to the Manager. These records shall include description and size of pipeline tested, date tested, joint type, number of joint bonds, joint bond resistance.
  - 5. Acceptable Resistance Before Backfilling
    - a. The continuity resistance will not be accepted if calculated to be greater than 120 percent of theoretical resistance of the bond cable. The resistance of the bond cables shall be obtained from the bond cable manufacturer. Any bonded joint which exceeds 120 percent of the theoretical resistance shall be replaced and retested for compliance.

6. After Backfilling

- a. The Contractor shall retest the continuity on all pipelines required to be bonded after the pipeline has been buried.

7. Test Procedure After Backfilling

- a. Test current shall be circulated through the pipeline using the No. 8 wires in the test stations. Wire size shall be determined by the Contractor and shall be sized for the test current (minimum of 25 amperes). The continuity resistance shall be calculated as an average per joint for the section being tested.

8. Record Keeping After Backfilling

- a. Records shall be made of each section of bonded pipe during the test and submitted to DWD. These records shall include description, location, and size of pipeline tested, starting location and direction of test, date of test, resistance of pipe per foot, length of pipe tested, measured resistance, calculated resistance, and percent of variance.

9. Acceptable Resistance After Backfilling

- a. The continuity resistance will not be accepted if calculated to be more than 120 percent of the theoretical resistance per joint. The resistance of the pipe per foot shall be obtained from the pipe manufacturer. The resistance of the joints shall be obtained from the bond cable manufacturer. If a section of pipe does not pass the continuity test, the Contractor shall locate the defective joint bond and repair it. After repairing, the continuity of that section will be retested.

C. Insulation Joints and Casings

1. The Contractor shall test each insulated joint and cased crossing. All damaged or defective insulation parts shall be replaced and retested. All electrical shorts to the casing shall be cleared and retested. Records shall be made of all insulated joints and cased crossing test and submitted to DWD for approval.

D. Test Stations

1. The Contractor shall test all test leads to ensure they were installed in accordance with the specifications. All defective test leads shall be repaired and/or replaced and retested. Records shall be made of all test stations tested and submitted to DWD for approval.

E. Cathodic Protection System

1. The Contractor shall test all cathodically protected pipelines to ensure that the protection levels are within the most recent NACE SP0169 standards. Records shall be made of all anode current output and pipe to-soil potential measurements performed and submitted to DWD for approval.

## F. Acceptance

1. All tests performed shall be reviewed and approved by DWD Engineer before the corrosion control work is accepted. DWD reserves the right to spot check any or all tests performed by the Contractor. All construction defects must be repaired and retested before the final acceptance is made. All unacceptable tests shall be retested by the Contractor at no additional cost to DWD.

Related drawings:

- DWD C1
- DWD C2
- DWD C3
- DWD C4
- DWD C5
- DWD C6
- DWD C7
- DWD C8
- DWD C9
- DWD C10
- DWD C11
- DWD C12
- DWD C13
- DWD C14
- DWD C15
- DWD C16
- DWD C17
- DWD C18
- DWD C19
- DWD C20
- DWD C21
- DWD C22
- DWD C23
- DWD C24
- DWD C25
- DWD C26
- DWD C27
- DWD C28
- DWD C29

END OF SECTION

## **6. Standard Drawings**

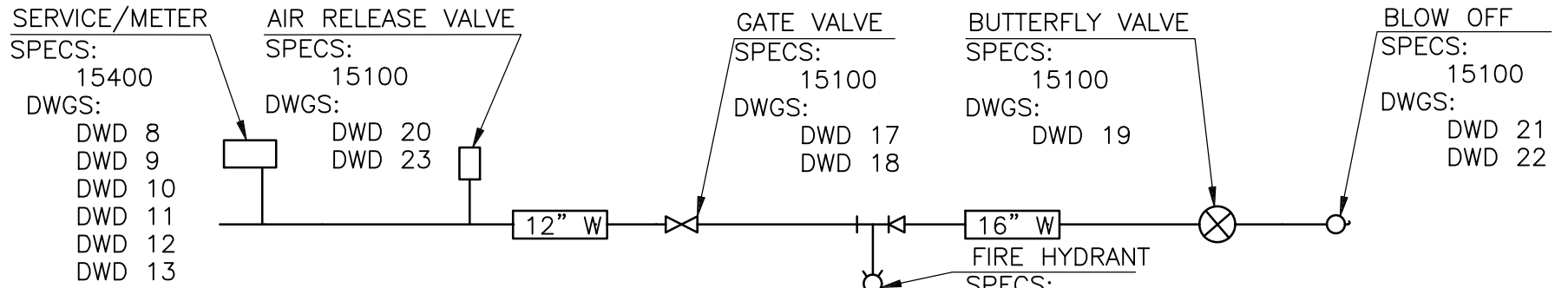

**PLAN**

NTS

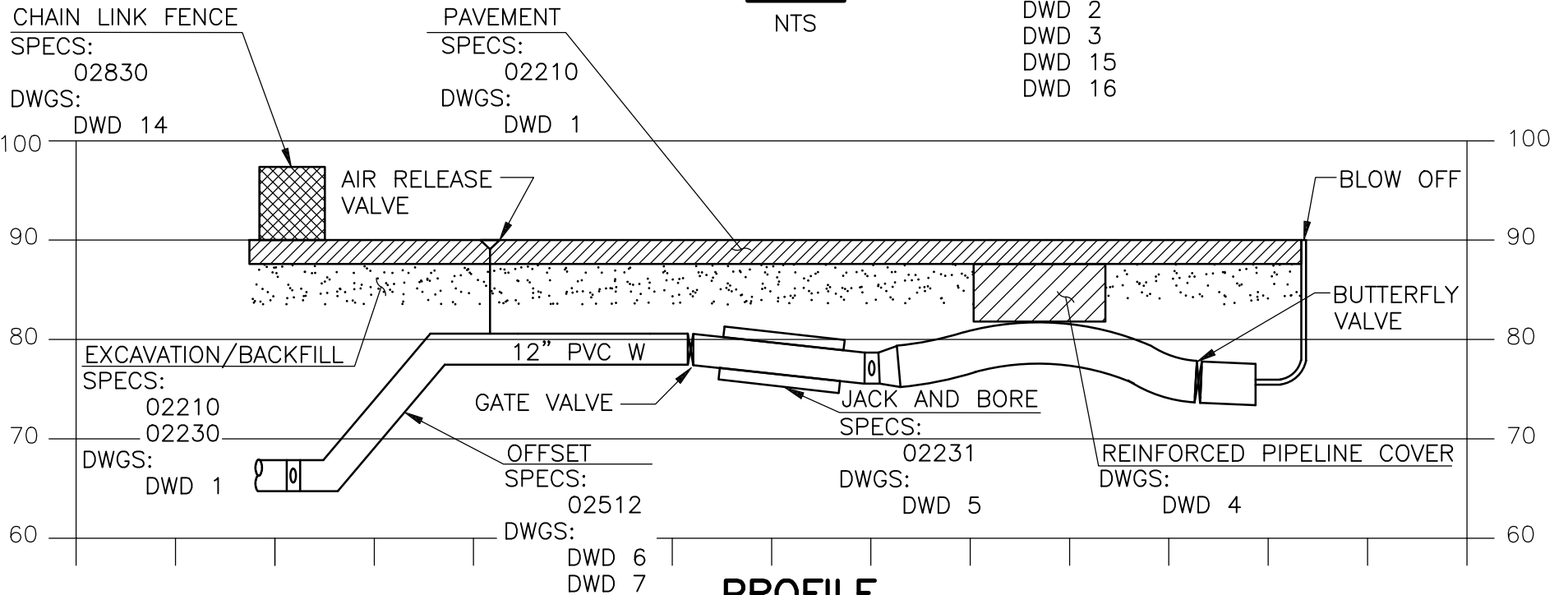

**PROFILE**

NTS

**DIABLO WATER DISTRICT**

STANDARD DRAWING  
**QUICK REFERENCE GUIDE**

DESIGNED WDB      DRAWN WKT      APPROVED WW      DATE OCTOBER, 2022      DWG. NO. **DWD 0**

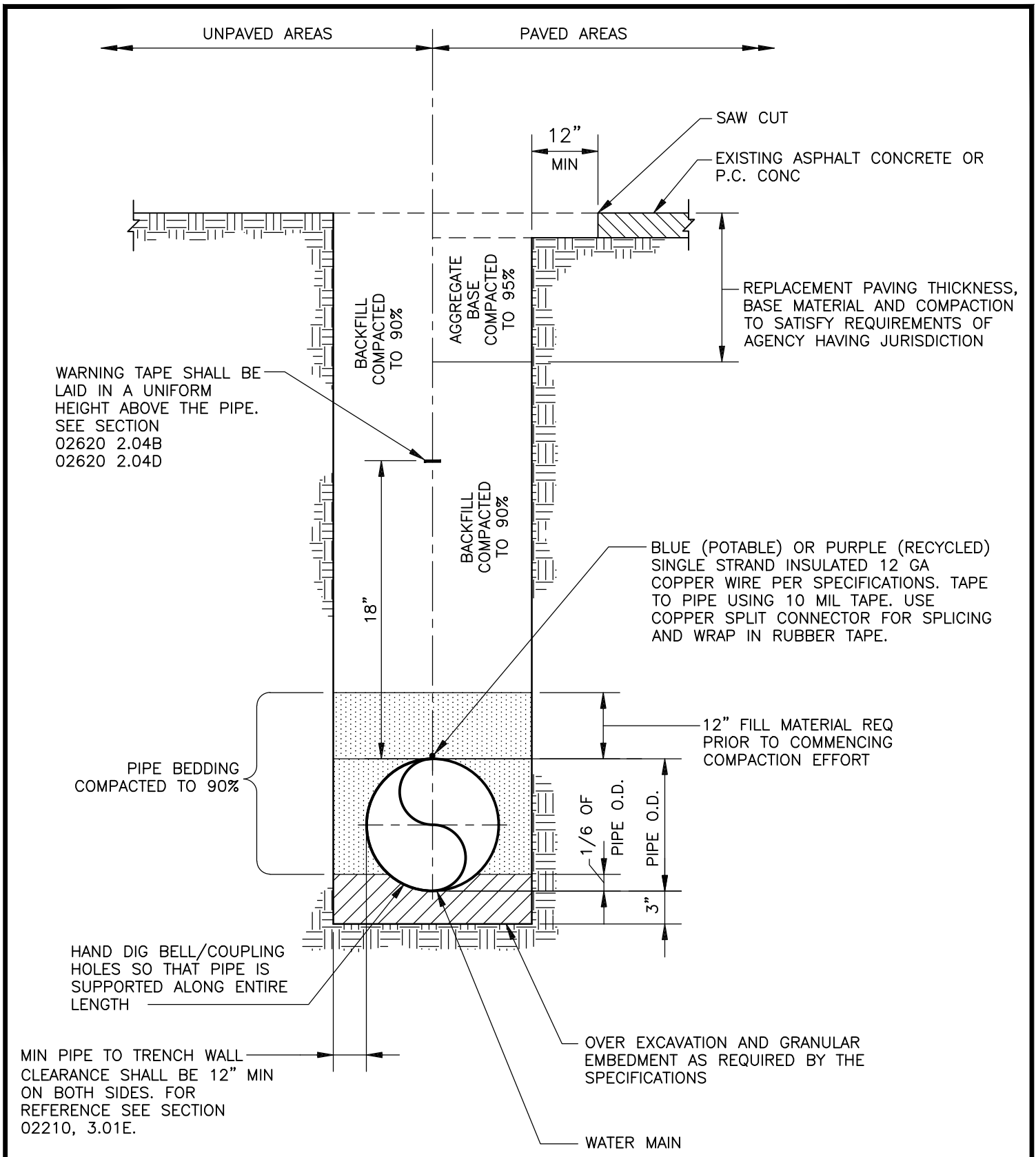

WARNING TAPE SHALL BE LAID IN A UNIFORM HEIGHT ABOVE THE PIPE. SEE SECTION 02620 2.04B 02620 2.04D

REPLACEMENT PAVING THICKNESS, BASE MATERIAL AND COMPACTION TO SATISFY REQUIREMENTS OF AGENCY HAVING JURISDICTION

BLUE (POTABLE) OR PURPLE (RECYCLED) SINGLE STRAND INSULATED 12 GA COPPER WIRE PER SPECIFICATIONS. TAPE TO PIPE USING 10 MIL TAPE. USE COPPER SPLIT CONNECTOR FOR SPLICING AND WRAP IN RUBBER TAPE.

12" FILL MATERIAL REQ PRIOR TO COMMENCING COMPACTION EFFORT

PIPE BEDDING COMPACTED TO 90%

HAND DIG BELL/COUPLING HOLES SO THAT PIPE IS SUPPORTED ALONG ENTIRE LENGTH

MIN PIPE TO TRENCH WALL CLEARANCE SHALL BE 12" MIN ON BOTH SIDES. FOR REFERENCE SEE SECTION 02210, 3.01E.

OVER EXCAVATION AND GRANULAR EMBEDMENT AS REQUIRED BY THE SPECIFICATIONS

WATER MAIN

NOTES:  
1. REFER TO SPEC SECTIONS 02210 & 02230.

<b>DIABLO WATER DISTRICT</b>		STANDARD DRAWING			
		<b>STANDARD TRENCH SECTION</b>			
DESIGNED <u>WDB</u>	DRAWN <u>WKT</u>	APPROVED <u>WW</u>	DATE <u>OCTOBER, 2022</u>	DWG. NO. <b>DWD 1</b>	



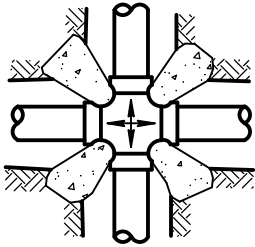

CROSS

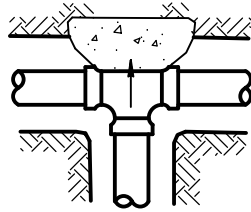

TEE

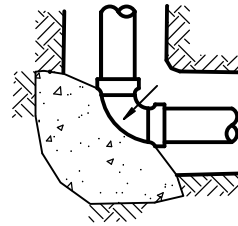

90° ELL

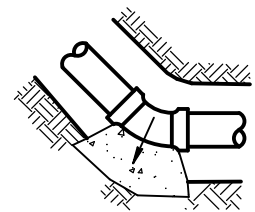

HORIZONTAL BEND

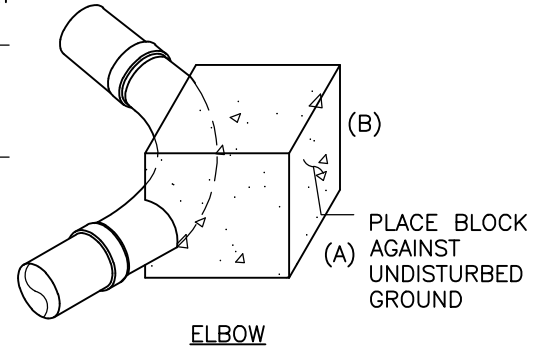
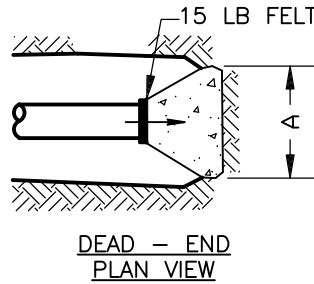
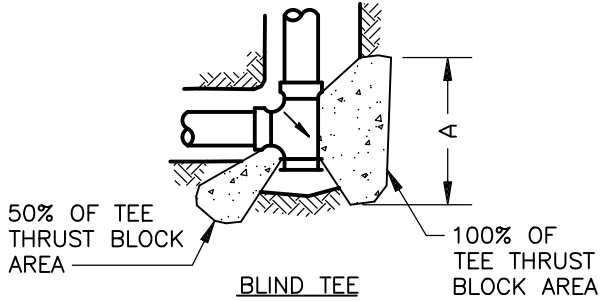

AREA (COMPUTED FROM TABLE)  
DIVIDED BY VERTICAL HEIGHT (B)  
EQUALS HORIZONTAL WIDTH (A)  
OF THRUST BLOCK

SHALL BE GREATER THAN  
THE LARGER OF EITHER  
A/2 OR B/2. 1' MIN.

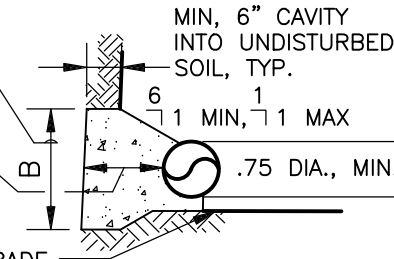

THRUST BLOCK AREA OF REQUIRED BEARING (SQ FT)  
BASED ON ALLOWABLE SOIL BEARING VALUE OF 2,000 PSF

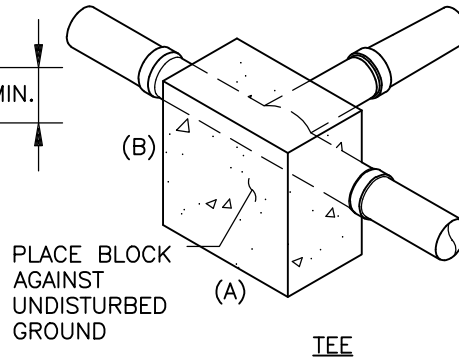

PIPE SIZE	DEAD END, TEE, BO OR PLUG	CROSS (EA BLOCK)	90° ELBOW	45° ELBOW & WYE	22.5° ELBOW
4"	1.5	1.0	2.0	1.5	1.0
6"	3.0	2.5	4.0	2.5	1.5
8"	5.0	2.5	7.0	4.0	2.0
10"	7.5	4.0	10.5	6.0	3.0
12"	10.5	5.5	15.0	8.0	4.5
14"	14.0	7.0	20.0	11.0	5.5
16"	18.0	9.0	25.5	14.0	7.0
18"	22.5	11.5	32.0	17.5	9.0
20"	27.5	14.0	39.0	21.0	11.0
24"	39.5	20.0	55.5	30.5	15.5

MULTIPLIERS FOR THRUST BLOCK AREAS	
ACTUAL SOIL BEARING VALUE	MULTIPLIER
1,000 PSF	2.0
1,500 PSF	1.33
2,000 PSF	1.0
2,500 PSF	0.8
3,000 PSF	0.67

EXAMPLE:  
ACTUAL SOIL BEARING VALUE = 1,000 PSF FOR 8"  
BLOW OFF  
REQUIRED AREA IS: (2.0)(5.0 SQ FT) = 10.0 SQ FT

NOTES:

1. THRUST BLOCKS SHALL BE CLASS B CONCRETE (5 SACK MIX)
2. MAXIMUM TEST PRESSURE = 150 PSI
3. THRUST BLOCK HORIZONTAL WIDTH (A) SHALL BE AT LEAST TWICE THE VERTICAL HEIGHT (B)
4. TOP OF THRUST BLOCK SHALL NOT BE PLACED WITHIN 2' OF FINISHED GRADE.
5. REFER TO SPEC SECTIONS 03100 AND 03304.

DIABLO WATER DISTRICT

STANDARD DRAWING  
CONCRETE THRUST BLOCKS

DESIGNED WDB

DRAWN WKT

APPROVED WW

DATE OCTOBER, 2022

DWG. NO. DWD 2

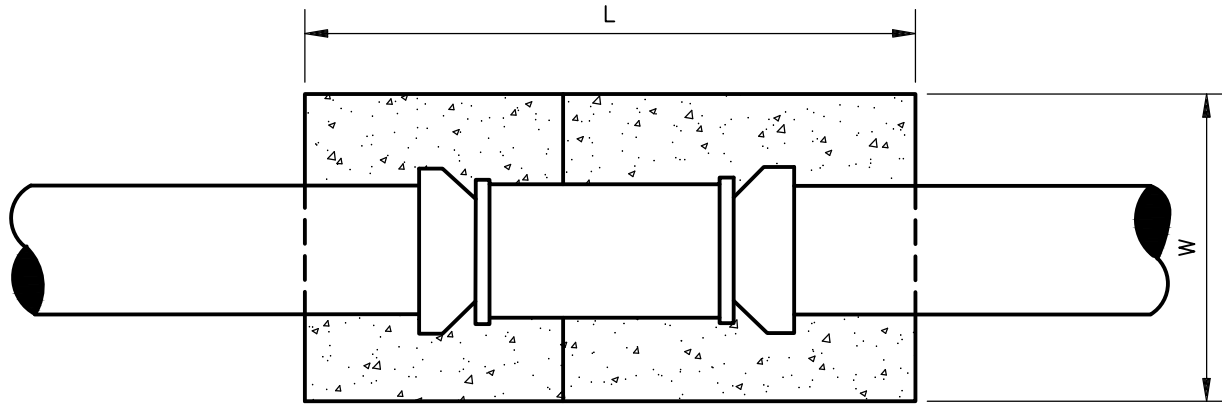

**PLAN**

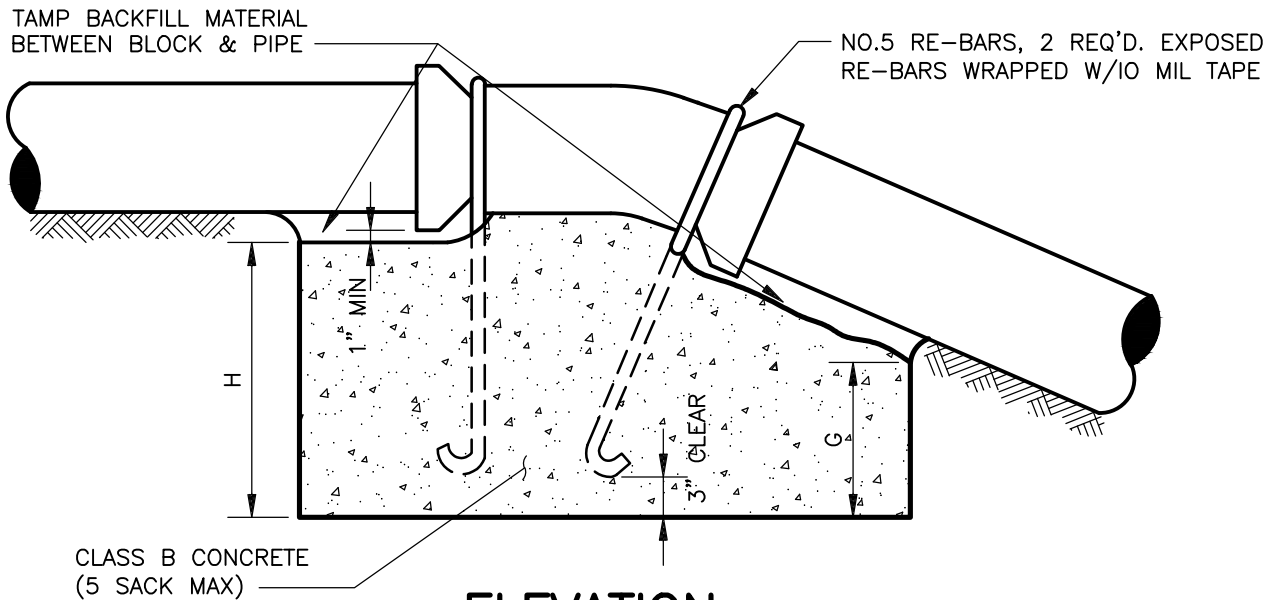

**ELEVATION**

**THRUST BLOCK DIMENSIONS ~ UPWARD THRUST**

PIPE SIZE	11-¼° BEND				22-½° BEND				45° BEND			
	L	W	H	G	L	W	H	G	L	W	H	G
4"	2'-0"	2'-0"	11"	9"	2'-0"	2'-0"	1'-2"	9"	3'-0"	2'-0"	2'-8"	1'-6"
6"	2'-0"	2'-0"	1'-3"	1'-0"	3'-0"	2'-0"	2'-8"	1'-0"	4'-0"	2'-6"	3'-11"	2'-6"
8"	3'-0"	2'-0"	2'-0"	1'-9"	4'-0"	2'-0"	3'-4"	2'-6"	5'-0"	3'-0"	5'-4"	3'-6"
10"	3'-6"	2'-6"	2'-2"	1'-9"	5'-0"	3'-0"	3'-6"	2'-6"	6'-0"	3'-0"	6'-8"	4'-6"
12"	4'-0"	3'-0"	2'-11"	2'-6"	6'-0"	3'-0"	3'-8"	2'-6"	7'-0"	3'-6"	8'-0"	5'-6"
14"	5'-0"	3'-4"	2'-6"	2'-0"	7'-6"	3'-5"	3'-5"	2'-8"	15'-10"	3'-6"	5'-4"	3'-10"
16"	6'-6"	3'-6"	2'-8"	2'-0"	9'-10"	3'-10"	3'-8"	2'-10"	15'-10"	3'-6"	5'-4"	3'-10"
18"	6'-10"	4'-0"	2'-11"	2'-4"	10'-10"	4'-0"	4'-4"	3'-4"	16'-4"	4'-0"	5'-10"	4'-4"
20"	7'-6"	4'-6"	3'-0"	2'-4"	11'-6"	4'-6"	4'-7"	3'-6"	17'-0"	4'-6"	6'-5"	4'-10"
24"	9'-4"	5'-0"	3'-5"	2'-6"	12'-0"	5'-0"	6'-2"	5'-0"	20'-0"	5'-0"	7'-6"	5'-6"

NOTES:  
1. REFER TO SPEC SECTION 03304.

DIABLO WATER DISTRICT

STANDARD DRAWING  
CONCRETE THRUST BLOCKS  
FOR VERTICAL BENDS

DESIGNED WDB DRAWN WKT APPROVED WW DATE OCTOBER, 2022 DWG. NO. **DWD 3**

WARNING TAPE,  
SEE SECTION  
02620 2.04B  
02620 2.04D

MIN 6" AC ABOVE SLAB

SAWCUT OR GRIND FULL DEPTH OF  
EXIST AC MIN 12" FROM EDGE OF  
SLAB FOR FINAL PAVING. REPLACE  
STREET SECTION FOR MIN 12"  
FROM EDGE OF SLAB

MIN 6" CL 2 AB OR PIPE  
BEDDING SAND, COMPACT TO  
MIN 95% REL COMPACTION

CL 2 AB OR PIPE BEDDING  
SAND, COMPACT TO MIN  
90% REL COMPACTION

MIN PIPE TO TRENCH WALL  
CLEARANCE SHALL BE 12" MIN  
ON BOTH SIDES

#5@12" OC CONT

MIN 10" THICK SLAB W/  
#6@12" OC W/ STD HOOKS EACH END (TOP)  
#6@6" OC W/OUT STD HOOKS (BOT)

3/2" CLEAR (TYP)

MIN 1'-0"  
(TYP)

DISTANCE VARIES, MIN 8"

EDGE OF PIPE TRENCH

OVER EXCAVATION AS DIRECTED BY ENGINEER, TO  
MIN 12". FILL W/ DRAIN ROCK OR CL 2 AB  
COMPACTED TO 90% MIN REL COMPACTION AND  
GEOFABRIC AS DIRECTED BY ENGINEER

NOTES:

1. CONCRETE REINFORCED PIPELINE COVER SECTION SHALL NOT BE SUBSTITUTED FOR INADEQUATE PIPELINE COVER WITHOUT DISTRICT APPROVAL.
2. CONCRETE SHALL BE CLASS B (5 SACK MIX)
3. REFER TO SPEC SECTIONS 02210, 02230, & 03304.

DIABLO WATER DISTRICT

STANDARD DRAWING

CONCRETE REINFORCED PIPELINE COVER SECTION

DESIGNED WDB

DRAWN WKT

APPROVED WW

DATE OCTOBER, 2022

DWG. NO. DWD 4

NOMINAL WATER PIPE SIZE	ACTUAL WATER PIPE OD	MIN WATER PIPE WALL THICKNESS	WATER PIPE CEMENT MORTAR LINING THICKNESS	WATER PIPE CEMENT MORTAR COATING THICKNESS	MIN CASING OD	MIN CASING WALL THICKNESS	PIPE INSULATOR WIDTH	NO. OF SKIDS PER PIPE INSULATOR
8"	8.625"	0.322"	3/8"	3/4"	16"	0.375"	8"	4
12"	14.00"	0.375"	3/8"	1"	24"	0.375"	12"	4
16"	18.00"	0.375"	1/2"	1"	30"	0.375"	12"	6
18"	20.00"	0.375"	1/2"	1"	30"	0.375"	12"	6

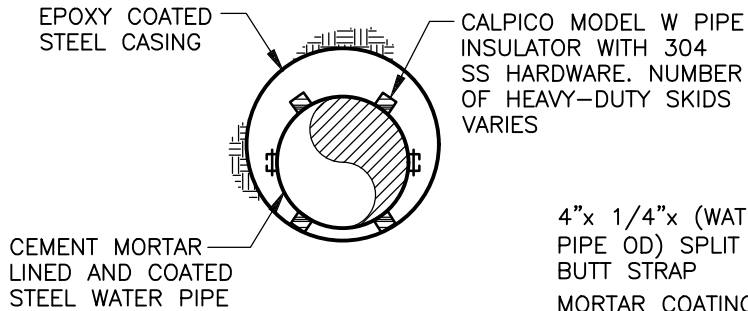

**SECTION 1**  
NTS

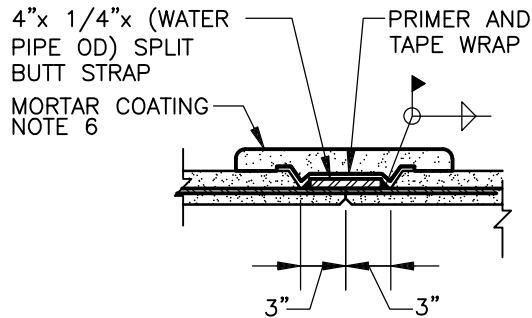

**SPLIT BUTT STRAP DETAIL**

NTS

**NOTES:**

- RAILROAD, CALTRANS, OR OTHER AGENCY REQUIREMENT MAY SUPERSEDE THESE DETAILS. NOTIFY DIABLO WATER DISTRICT SHOULD THIS BE THE CASE.
- ALL CASING JOINTS ARE TO BE WELDED WATERTIGHT. CONDUIT TO SLOPE SLIGHTLY IN ONE DIRECTION.
- WATER PIPE SHALL BE JOINED WITH SPLIT BUTT STRAPS.
- OPTIONAL AIR TEST. AFTER WATER PIPE IS INSTALLED WITHIN THE AIR CASING, THE CONTRACTOR HAS THE OPTION TO PERFORM A PRESSURIZED AIR TEST PRIOR TO THE REQUIRED HYDROSTATIC TEST. THE PRESSURE AND DURATION OF THE AIR TEST SHALL BE DETERMINED BY THE CONTRACTOR.
- NOTE TEST RESULTS FOR BLOWN SAND PER SECTION 16640.
- MORTAR COATING SHALL BE 2 PARTS SAND:1 PART CEMENT. MORTAR DIAPERS WILL NOT BE ALLOWED. REFER TO SPEC SECTIONS 02231 & 02512.

PACK ANNULAR SPACE WITH MORTAR TO SEAL CASING (TYP) BURKE NON FERROUS NON SHRINK GROUT, OR EQUAL, WITH PEA GRAVEL

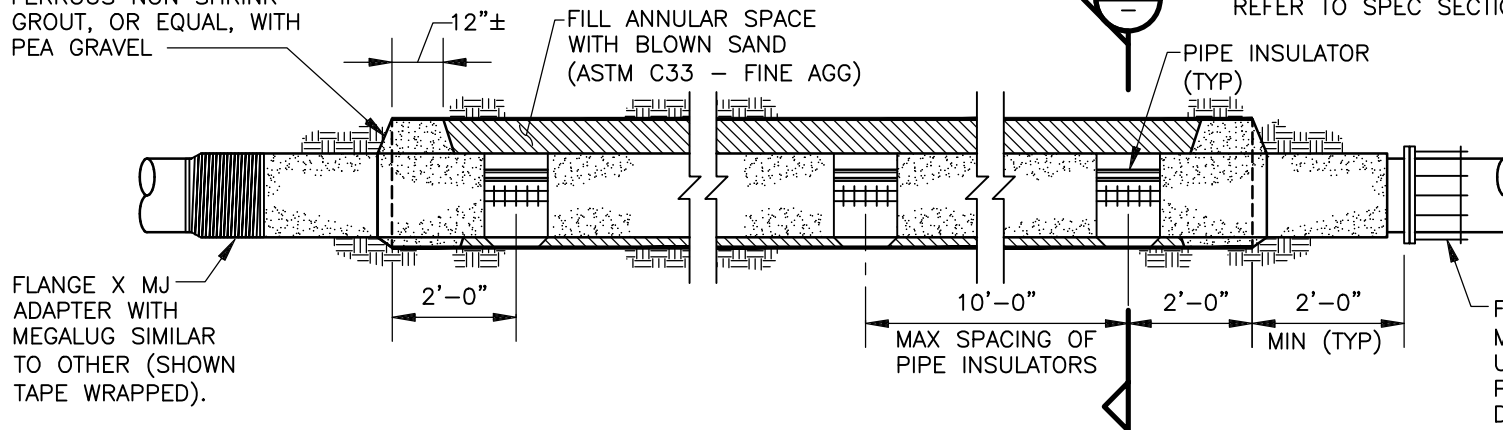

DIABLO WATER DISTRICT

STANDARD DRAWING  
PARTIAL BORE AND CASE REQUIREMENTS

DESIGNED WDB

DRAWN WKT

APPROVED WW

DATE OCTOBER, 2022

DWG. NO. DWD 5

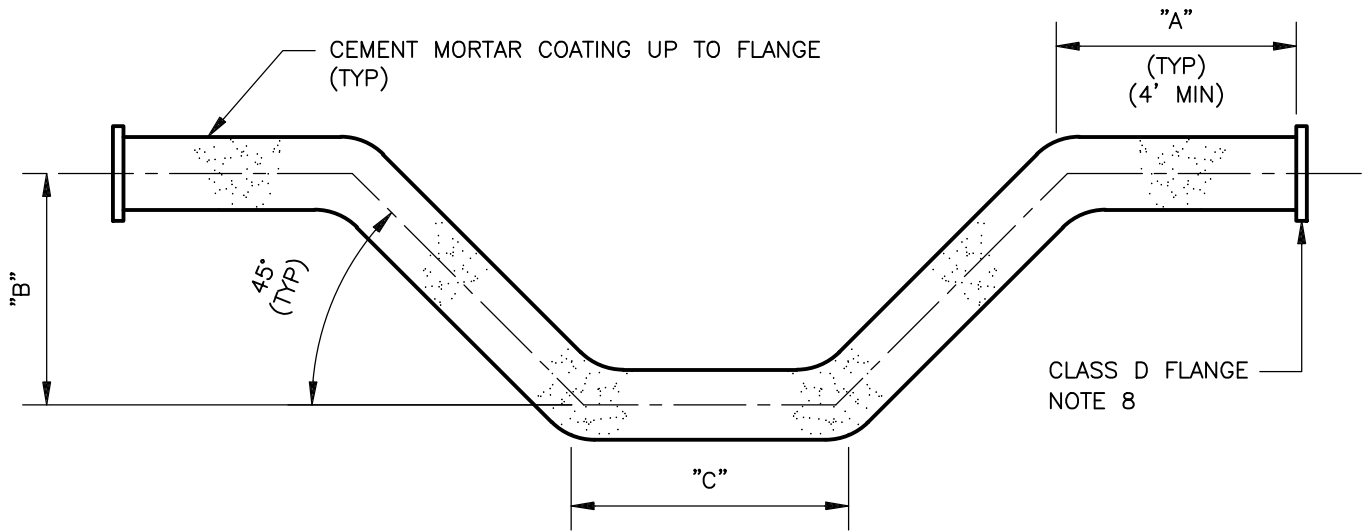

**NOTES:**

1. NOMINAL STEEL PIPE DIMENSIONS ON DRAWINGS REPRESENT THE MINIMUM PIPE INSIDE DIAMETER AFTER LINING.
2. STEEL PIPE SHALL CONFORM TO AWWA C200. LININGS AND COATINGS SHALL CONFORM TO AWWA C205. COATING ON FLANGED ENDS SHALL REACH EDGE OF FLANGE.
3. DOUBLE OFFSET TO BE FABRICATED BY WELDING USING FOUR 45° BUTT WELDING LONG RADIUS ELBOWS. MITRED ELBOWS CONFORMING TO AWWA C208 MAY BE USED ON 16" AND 18" OFFSETS.
4. "C" DIMENSIONS AS REQUIRED, 4'-0" MINIMUM LENGTH.
5. "A" AND "B" DIMENSIONS AS REQUIRED.
6. CEMENT MORTAR LINING SHALL BE SHOP APPLIED AND BE FINISHED SQUARE AND UNIFORM AT THE ENDS OF THE PIPE.
7. OFFSETS MAY BE FABRICATED IN PIECES TO AID INSTALLATION IN THE FIELD. SUCH PIECES TO BE JOINED WITH A WELDED 4" WIDE BY 0.25" THICK (MIN) STEEL BUTTSTRAP. BUTTSTRAP JOINTS TO BE COATED WITH TAPE AND BITUMEN BEFORE BACKFILLING. ALTERNATELY, PIECES MAY BE JOINED BY FLANGES. FLANGES TO BE COATED WITH BITUMEN & TAPE AFTER INSTALLATION.
8. FLANGE PATTERN TO MATCH CONNECTING FITTING. FLANGE TO PIPE WELD SHALL CONFORM TO AWWA C207. FLANGES SHALL BE EPOXY COATED.
9. REFER TO SPEC SECTIONS 02512 & 02675.
10. 1 1/2" COUPLING WITH CP BUSHING TO BE USED.

NOMINAL PIPE SIZE (MIN ID AFTER LINING)	STANDARD PIPE OD TO ACHIEVE REQD MIN ID	TYP PIPE ID AFTER LINING OF STANDARD PIPE SIZES	PIPE MINIMUM WALL THICKNESS	CEMENT MORTAR LINING THICKNESS	CEMENT MORTAR COATING THICKNESS	"A"
6"	8.625"	7.481"	0.322"	1/4"	3/4"	4'-0"
8"	10.75"	9.520"	0.365"	1/4"	3/4"	4'-0"
10"	12.75"	11.375"	0.375"	5/16"	3/4"	4'-0"
12"	14.0"	12.625"	0.375"	5/16"	3/4"	4'-0"
16"	18.0"	16.625"	0.375"	5/16"	3/4"	4'-0"
18"	20.0"	18.625"	0.375"	5/16"	3/4"	4'-0"
20"	22.0"	20.50"	0.375"	3/8"	3/4"	4'-0"
24"	26.0"	24.50"	0.375"	3/8"	3/4"	4'-0"

**DIABLO WATER DISTRICT**

STANDARD DRAWING  
**DOUBLE OFFSET STEEL PIPE, CEMENT MORTAR LINED AND COATED, 6" TO 24"**

DESIGNED WDB

DRAWN WKT

APPROVED WW

DATE OCTOBER, 2022

DWG. NO. **DWD 6**

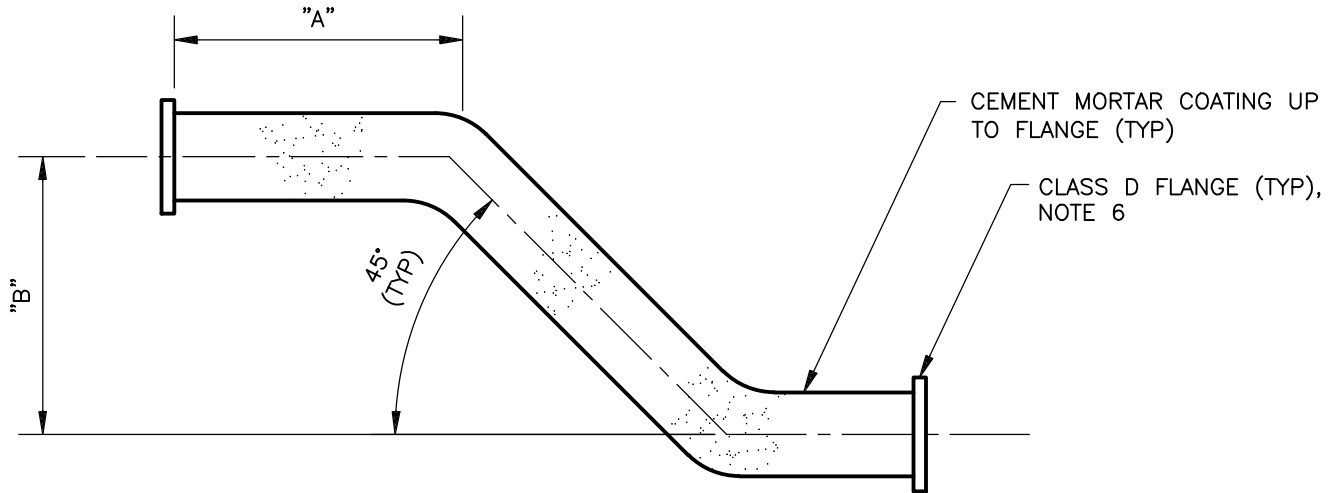

NOTES:

1. NOMINAL STEEL PIPE DIMENSIONS ON DRAWINGS REPRESENT THE MINIMUM PIPE INSIDE DIAMETER AFTER LINING.
2. STEEL PIPE SHALL CONFORM TO AWWA C200. LININGS AND COATINGS SHALL CONFORM TO AWWA C205.
3. SINGLE OFFSET TO BE FABRICATED BY WELDING USING TWO 45° BUTT WELDING LONG RADIUS ELBOWS. MITRED ELBOWS CONFORMING TO AWWA C208 MAY BE USED ON 16" AND 18" OFFSETS.
4. "B" DIMENSION AS REQUIRED.
5. CEMENT MORTAR LINING SHALL BE SHOP APPLIED AND BE FINISHED SQUARE AND UNIFORM AT THE ENDS OF THE PIPE.
6. FLANGE PATTERN TO MATCH CONNECTING FITTING. FLANGE TO PIPE WELD SIZE SHALL CONFORM TO AWWA C207. FLANGES SHALL BE EPOXY COATED.
7. REFER TO SPEC SECTIONS 02512 & 02675.

NOMINAL PIPE SIZE (MIN ID AFTER LINING)	STANDARD PIPE OD TO ACHIEVE REQD MIN ID	TYP PIPE ID AFTER LINING OF STANDARD PIPE SIZES	PIPE MINIMUM WALL THICKNESS	CEMENT MORTAR LINING THICKNESS	CEMENT MORTAR COATING THICKNESS	"A"
6"	8.625"	7.481"	0.322"	1/4"	3/4"	4'-0"
8"	10.75"	9.520"	0.365"	1/4"	3/4"	4'-0"
10"	12.75"	11.375"	0.375"	5/16"	3/4"	4'-0"
12"	14.0"	12.625"	0.375"	5/16"	3/4"	4'-0"
16"	18.0"	16.625"	0.375"	5/16"	3/4"	4'-0"
18"	20.0"	18.625"	0.375"	5/16"	3/4"	4'-0"
20"	22.0"	20.50"	0.375"	3/8"	3/4"	4'-0"
24"	26.0"	24.50"	0.375"	3/8"	3/4"	4'-0"

DIABLO WATER DISTRICT

STANDARD DRAWING  
**SINGLE OFFSET STEEL PIPE, CEMENT  
MORTAR LINED AND COATED, 6" TO 24"**

DESIGNED WDB

DRAWN WKT

APPROVED WW

DATE OCTOBER, 2022

DWG. NO. **DWD 7**

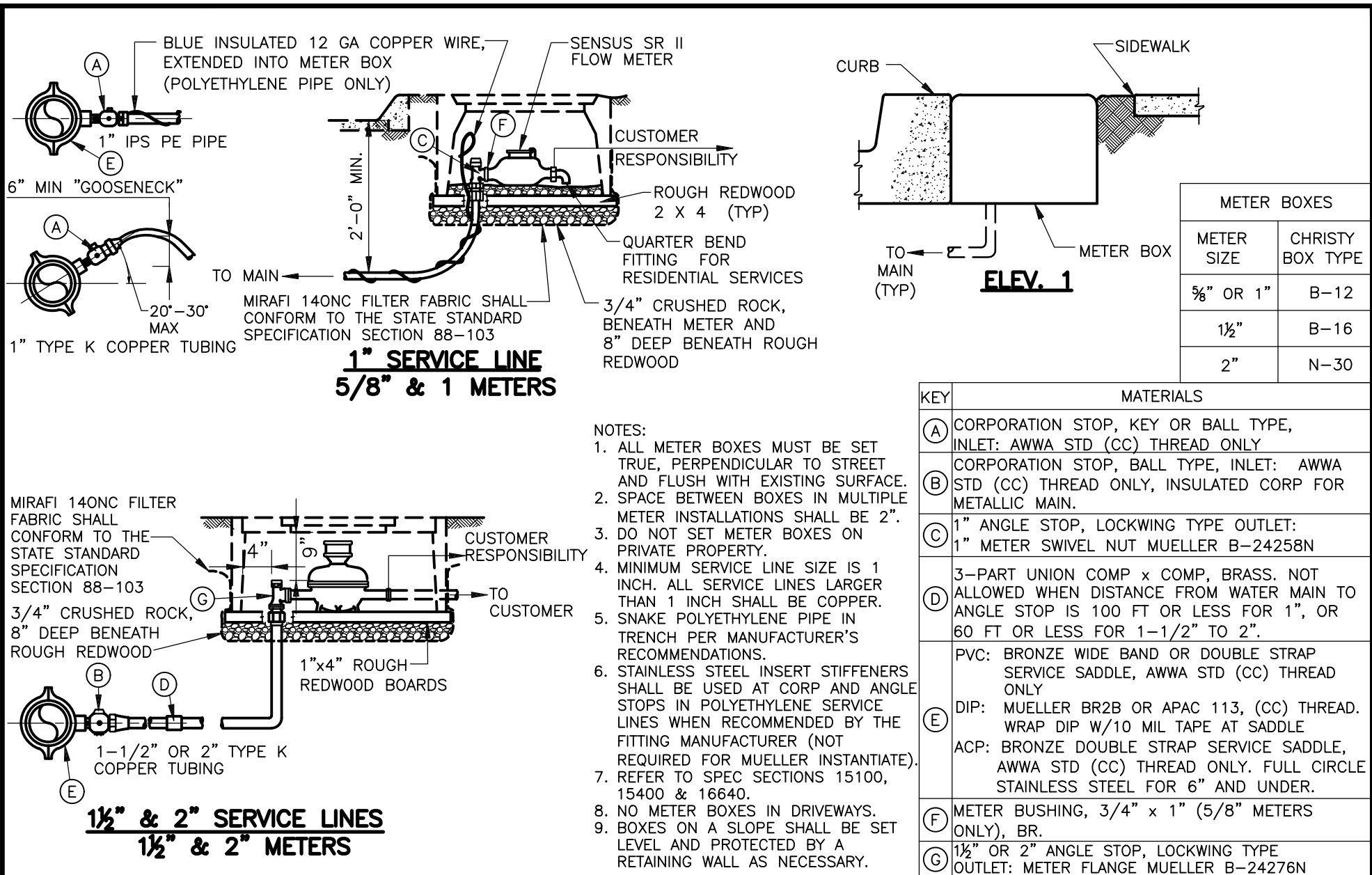

METER BOXES	
METER SIZE	CHRISTY BOX TYPE
5/8" OR 1"	B-12
1 1/2"	B-16
2"	N-30

KEY	MATERIALS
(A)	CORPORATION STOP, KEY OR BALL TYPE, INLET: AWWA STD (CC) THREAD ONLY
(B)	CORPORATION STOP, BALL TYPE, INLET: AWWA STD (CC) THREAD ONLY, INSULATED CORP FOR METALLIC MAIN.
(C)	1" ANGLE STOP, LOCKWING TYPE OUTLET: 1" METER SWIVEL NUT MUELLER B-24258N
(D)	3-PART UNION COMP x COMP, BRASS. NOT ALLOWED WHEN DISTANCE FROM WATER MAIN TO ANGLE STOP IS 100 FT OR LESS FOR 1", OR 60 FT OR LESS FOR 1-1/2" TO 2".
(E)	PVC: BRONZE WIDE BAND OR DOUBLE STRAP SERVICE SADDLE, AWWA STD (CC) THREAD ONLY DIP: MUELLER BR2B OR APAC 113, (CC) THREAD. WRAP DIP W/10 MIL TAPE AT SADDLE ACP: BRONZE DOUBLE STRAP SERVICE SADDLE, AWWA STD (CC) THREAD ONLY. FULL CIRCLE STAINLESS STEEL FOR 6" AND UNDER.
(F)	METER BUSHING, 3/4" x 1" (5/8" METERS ONLY), BR.
(G)	1 1/2" OR 2" ANGLE STOP, LOCKWING TYPE OUTLET: METER FLANGE MUELLER B-24276N

STANDARD DRAWING

**SERVICE AND METER BOX INSTALLATIONS, 5/8" TO 2"**

DIABLO WATER DISTRICT

DESIGNED WDB      DRAWN WKT      APPROVED WW      DATE OCTOBER, 2022      DWG. NO. DWD 8

CHRISTY B44 UTILITY BOX W/B44-62D GALV LID. USE POLYLITE LID IF NO TRAFFIC AS DIRECTED BY DWD.

4" ELBOW  
4" SERVICE  
THRUST BLOCK AS DIRECTED BY DIABLO WATER DISTRICT

4" SENSUS COMPOUND METER WITH STRAINER. CENTER IN BOX

**PLAN**  
NTS

SLOPE SLAB TO DRAIN

CUSTOMER'S PIPING

2" BYPASS

MAINTAINED BY DWD | MAINTAINED BY CUSTOMER

**NOTES:**

1. OMIT 2" BYPASS IF DIRECTED BY DWD.
2. REFER TO SPEC SECTIONS 02210, 03304, 03600, & 15400.

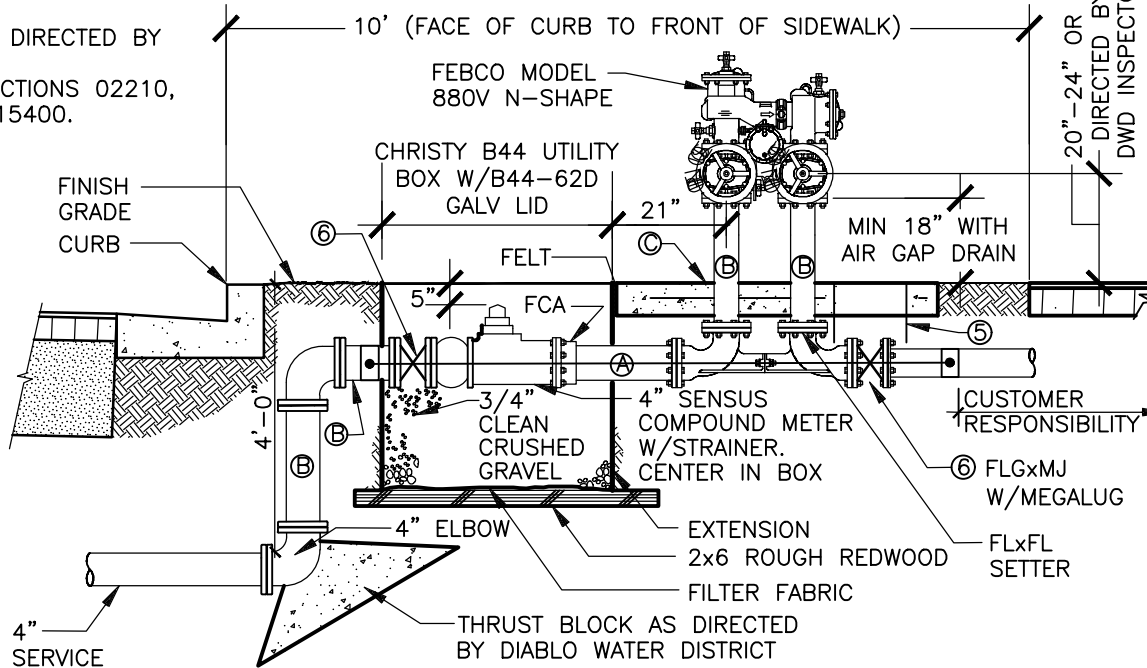

ITEM	DESCRIPTION
①	BRONZE MUELLER SADDLE WITH 2" OUTLET
②	2"-H-15014N MUELLER CC THREAD CORPORATION VALVE WITH F.I.P. THREADED OUTLET.
③	2"-H-15531N MUELLER QUARTER BEND COUPLING, COMPRESSION CONNECTION FOR CTS O.D. TUBING X M.I.P.
④	2" COPPER TUBING
⑤	G5 CHRISTY VALVE BOX
⑥	MUELLER 4" GATE VALVE
⑦	MUELLER 300 BALL CURB VALVE B-25209N-2" CTS IN B9 BOX.
A	4" - DIP FLxPE SPOOL LENGTH AS REQUIRED, C-104.
B	4" - DIP FLxFL SPOOL LENGTH AS REQUIRED, C-104.
C	6' WIDE - 4" THICK CONCRETE CENTERED W/#4 BARS @ 12" O.C. EACH WAY. ALL JOINTS FLANGED WITH 304 SS BOLTS.

\* INSTALLATION AS SHOWN IS FOR 4-INCH METER. REDUCE PIPES AND VALVES TO 3-INCH FOR 3-INCH METER INSTALLATION.

**SENSUS 4" COMPOUND METER INSTALLATION (NTS)**  
SHOWN W/ FEBCO MODEL LF880V N-SHAPE REDUCED PRESSURE ASSEMBLY

DIABLO WATER DISTRICT

STANDARD DRAWING  
**3" AND 4" COMPOUND METER INSTALLATION**

DESIGNED <u>WDB</u>	DRAWN <u>WKT</u>	APPROVED <u>WW</u>	DATE <u>OCTOBER, 2022</u>	DWG. NO. <u>DWD 9</u>
---------------------	------------------	--------------------	---------------------------	-----------------------



REDUCERS LOCATED  
HERE, IF NEEDED

4" SERVICE LINE

THRUST BLOCK AS  
DIRECTED BY DIABLO  
WATER DISTRICT

4" SENSUS COMPOUND  
METER WITH STRAINER.  
CENTER IN BOX (TYP)

CHRISTY B44 UTILITY BOX  
W/B44-62D GALV LID.  
USE POLYLITE LID IF NO TRAFFIC  
AS DIRECTED BY DWD. (TYP 3)

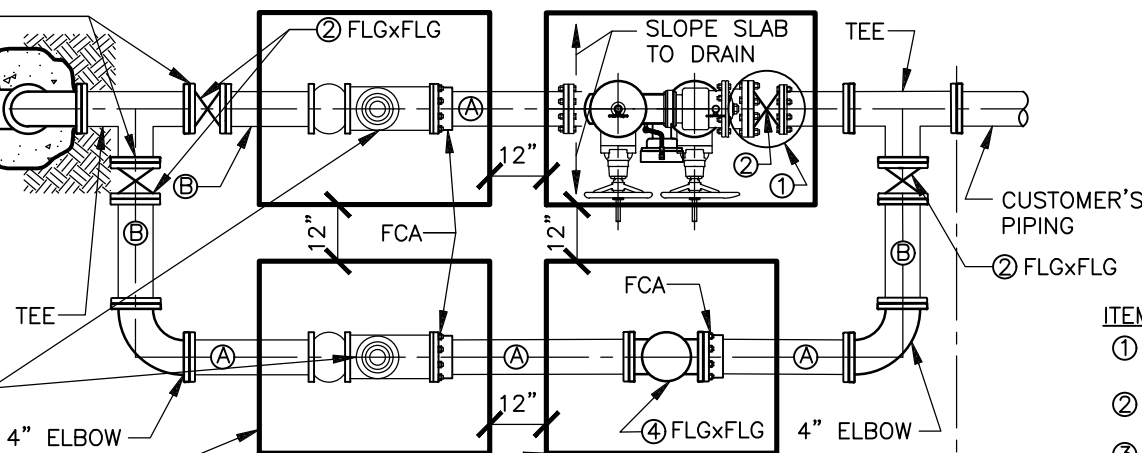

**PLAN**  
NTS

OWNED BY DWD | OWNED BY CUSTOMER

- | ITEM | DESCRIPTION   |
|------|---|
| ①    | G5 CHRISTY VALVE BOX.   |
| ②    | MUELLER 4" GATE VALVE.  |
| ③    | MUELLER 300 BALL CURB VALVE B-25209N-2" CTS.  |
| ④    | MUELLER 851A 4" CHECK VALVE W/ EPDM FLEXIBLE DISC.  |
| ⑤    | 4" FLG x 2" TAP FOR TEMPORARY WATER CONNECTION BY DWD.  |
| Ⓐ    | 4" - DIP FLxPE SPOOL LENGTH AS REQUIRED, AWWA C104.   |
| Ⓑ    | 4" - DIP FLxFL SPOOL LENGTH AS REQUIRED, AWWA C104.   |
| Ⓒ    | 6' WIDE - 4" THICK CONCRETE CENTERED W/#4 BARS @ 12" O.C. EACH WAY. ALL JOINTS FLANGED WITH 304 SS BOLTS. |

**NOTES:**  
1. REFER TO SPEC SECTIONS  
02210, 03304, 03600, &  
15400.

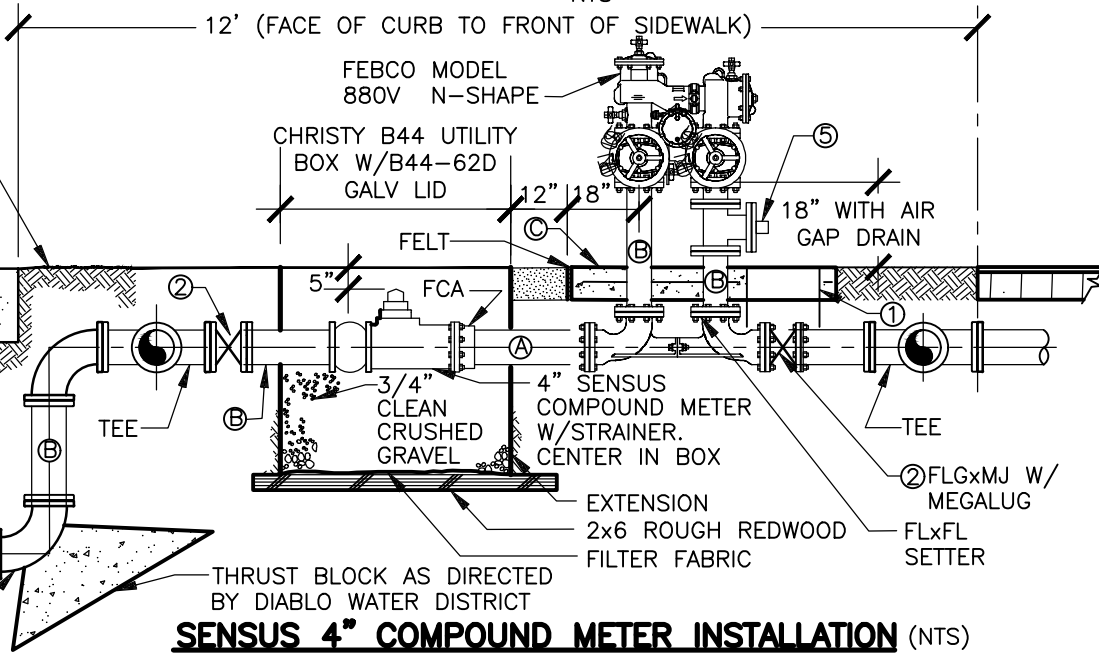

**SENSUS 4" COMPOUND METER INSTALLATION (NTS)**  
SHOWN W/ FEBCO MODEL LF880V N-SHAPE REDUCED PRESSURE ASSEMBLY

\* INSTALLATION AS SHOWN IS FOR 4-INCH METER. REDUCE PIPES AND VALVES TO 3-INCH FOR 3-INCH METER INSTALLATION.

**DIABLO WATER DISTRICT**

STANDARD DRAWING

**3" AND 4" COMPOUND METER INSTALLATION WITH BYPASS**

DESIGNED WDB | DRAWN KBR | APPROVED WW | DATE OCTOBER, 2022 | DWG. NO. DWD 9A

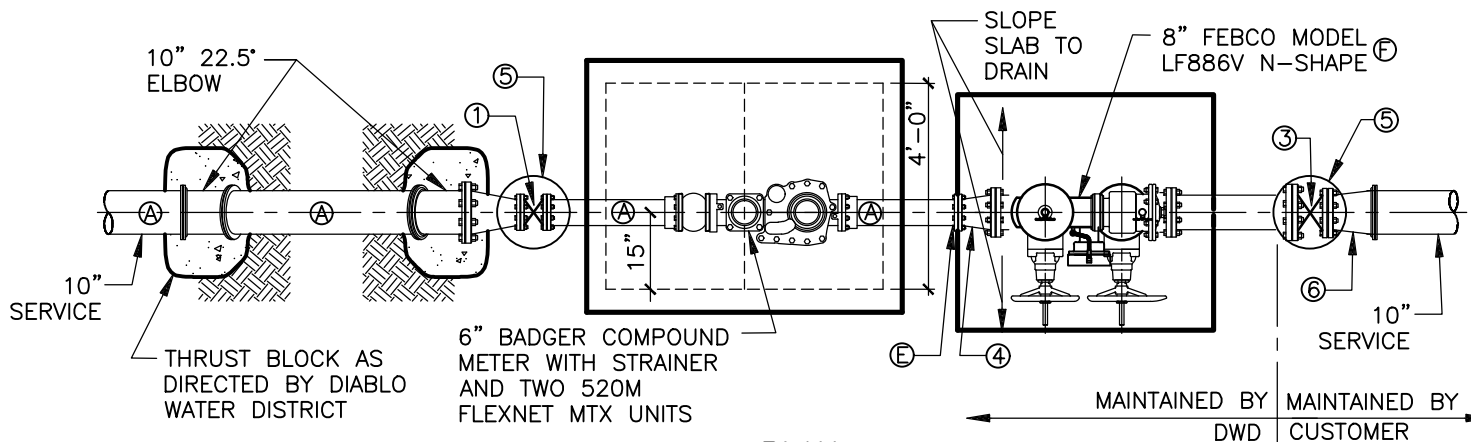

**PLAN**  
NTS

**NOTES:**  
1. REFER TO SPEC SECTIONS  
02210, 03304, 03600, &  
15400.

- | <u>ITEM</u> | <u>DESCRIPTION</u>  |
|-------------|---|
| ①           | MUELLER 6" GATE VALVE   |
| ②           | 10" X 6" REDUCER  |
| ③           | MUELLER 8" GATE VALVE   |
| ④           | 6" X 8" REDUCER   |
| ⑤           | G5 CHRISTY VALVE BOX  |
| ⑥           | 8" X 10" REDUCER  |
| ⑦           | ADJUSTABLE PIPE SUPPORT   |
| ⑧           | NON-TRAFFIC RATED DOUBLE LEAF GALV STEEL HATCH WITH SPRING ASSIST; LOCKABLE WITH RECESSED PADLOCK COVER.  |
| Ⓐ           | DIP FLxPE SPOOL LENGTH AS REQUIRED, W/ FCA, C-104.  |
| Ⓑ           | DIP FLxFL SPOOL LENGTH AS REQUIRED, C-104.  |
| Ⓒ           | 6' WIDE - 4" THICK CONCRETE CENTERED W/#4 BARS @ 12" O.C. EACH WAY. ALL JOINTS FLANGED WITH 304 SS BOLTS. |
| Ⓓ           | DIP PExPE SPOOL W/ MEGALUG RESTRAINTS LENGTH AS REQUIRED, C-104.  |
| Ⓔ           | A HORIZONTAL BEND CAN BE INSTALLED UPSTREAM OF THE REDUCER IF NEEDED TO ACCOMMODATE SURFACE LAYOUT.       |
| Ⓕ           | PROVIDE WITH SENSUS SR2 METER AND 520M FLEXNET MTX UNIT.  |

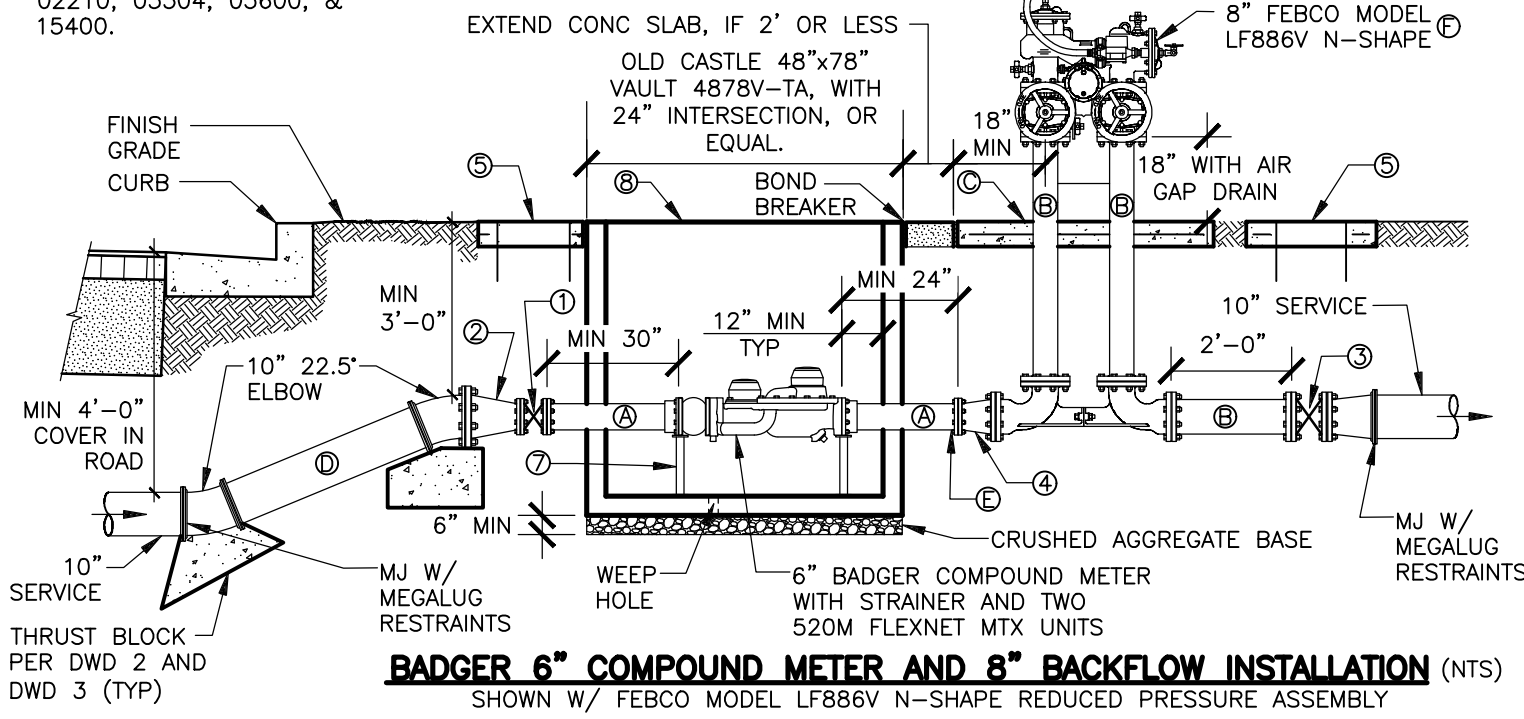

**BADGER 6" COMPOUND METER AND 8" BACKFLOW INSTALLATION** (NTS)  
SHOWN W/ FEBCO MODEL LF886V N-SHAPE REDUCED PRESSURE ASSEMBLY

<b>DIABLO WATER DISTRICT</b>	STANDARD DRAWING			
	<b>6" COMPOUND METER AND 8" BACKFLOW INSTALLATION</b>			

DESIGNED <u>WDB</u>	DRAWN <u>MAR</u>	APPROVED <u>WW</u>	DATE <u>OCTOBER, 2022</u>	DWG. NO. <u>DWD 9B</u>
---------------------	------------------	--------------------	---------------------------	------------------------

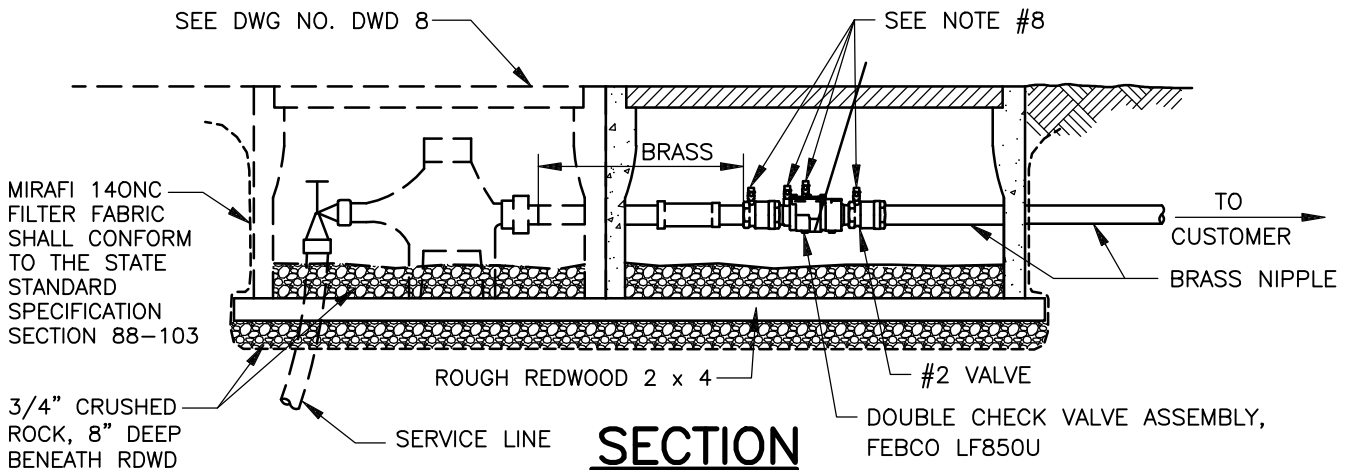
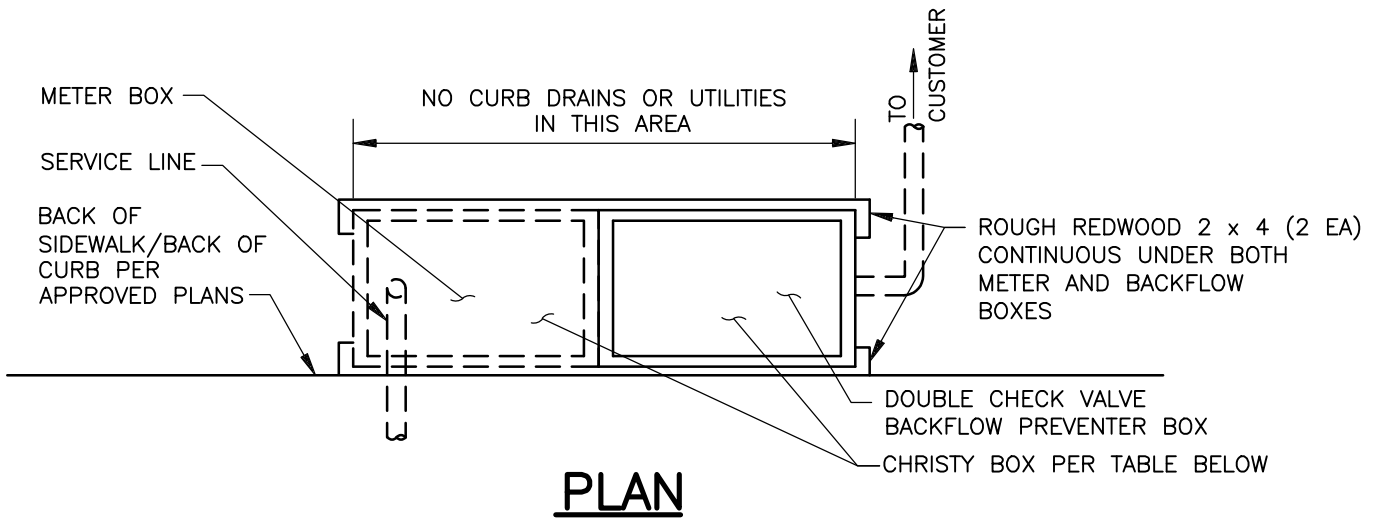

METER SIZE	5/8"	1"	1"*	1 1/2"	2"
BACKFLOW PREVENTER SIZE	1"	1"	1 1/4"	1 1/2"	2"
BOX MINIMUM INSIDE LENGTH	17"	17"	20"	20"	22"
CHRISTY BOX	B-12	B-12	B-16	B-16	B-30

NOTES:

\* REQUIRED WITH FIRE SPRINKLER SYSTEMS

- SOME MEANS OF PRESSURE RELIEF MUST BE PROVIDED BY THE CUSTOMER SO THAT EXCESSIVE PRESSURE WILL NOT DISRUPT CUSTOMER'S PIPING OR FIXTURES.
- ALL COMPONENTS SHALL BE BRASS.
- INSTALLATION MUST BE MADE ADJACENT TO METER.
- BACK FLOW PREVENTER BOX SHALL BE LOCATED OUTSIDE OF TRAFFIC AREAS IF FEASIBLE. IF IN TRAFFIC AREA, FURNISH WITH TRAFFIC COVER.
- WATER SERVICES SHALL BE INSTALLED AT LEAST 5 FEET FROM SEWER LATERALS.
- IF CONSUMER'S PIPING IS GALVANIZED IRON, THE UNION BETWEEN THE BACKFLOW PREVENTER AND THE CUSTOMER'S PIPING SHALL BE DIELECTRIC.
- HOUSES WITH FIRE SPRINKLERS SHOULD USE 1" METER WITH 1-1/4" BACKFLOW PREVENTER.
- REFER TO SPEC SECTION 15400.
- CONTRACTOR TO SUPPLY AND INSTALL 1/4" MIP X 1/4" FLARE ADAPTER TEST FITTINGS (TOTAL OF 4).
- WATER UTILITY BOXES SHALL ONLY CONTAIN DWD OWNED FACILITIES.
- SEE SUBMITTAL LOG FOR DETAIL ON METER LID SPECIFICATION.
- METER AND BACKFLOW EACH NEED BE CENTERED IN THEIR BOX.

DIABLO WATER DISTRICT

STANDARD DRAWING  
**DOUBLE CHECK VALVE  
 BACKFLOW PREVENTER INSTALLATION, 3/4" TO 2"**

DESIGNED WDB

DRAWN WKT

APPROVED WW

DATE OCTOBER, 2022

DWG. NO. **DWD 10**

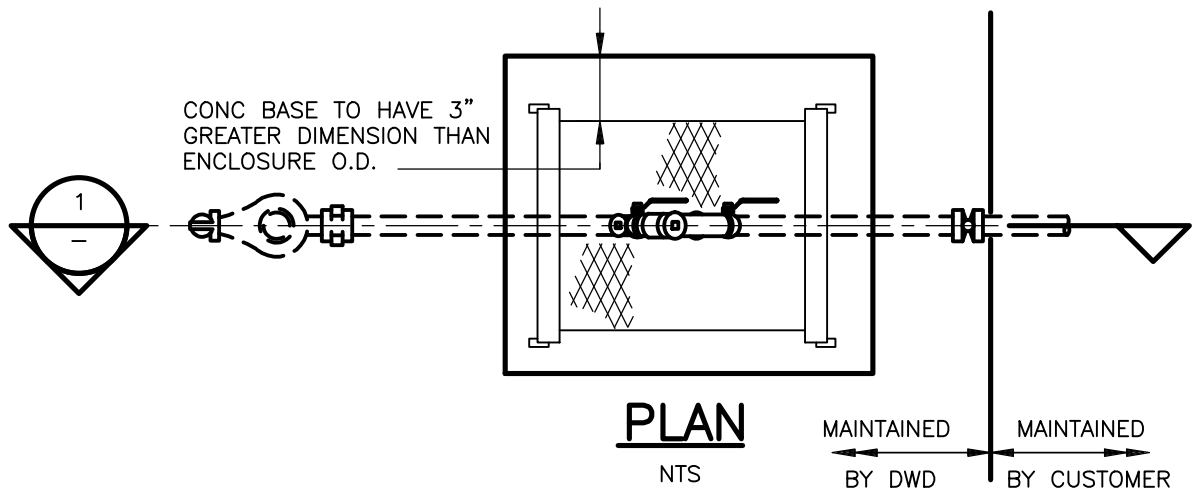

FEBCO FREEZE BAG,  
OR APPROVED EQUAL

3 1/2" CONC BASE ON 6" OF 3/4"  
COMPACTED DRAIN ROCK

PIPE/FITTINGS TO BE THD  
BRASS, SIZE TO MATCH RPBP

METER & METER BOX SEE  
DWG NO. DWD 8

FEBCO LF825YA RPBP  
WITH BALL VALVES, BR.  
SIZE TO MATCH METER  
(FOR 5/8" METER USE 1" RPBP)

NOTE 5

BPDI GUARDSHACK, HINGED  
PROTECTIVE ENCLOSURE WITH  
GATE SIZED PER DWD  
REQUIREMENTS. FOREST  
GREEN, STAINLESS STEEL,  
POWDER COATED

HASP (2)

PVC CLASS 200  
SLEEVES 2-TYP

HINGES (4)

CHRISTY G5  
VALVE BOX, OR  
APPROVED EQUAL

TO CUSTOMER

BRASS PIPE / FITTINGS

INSTALL BRASS BALL  
VALVE FOR  
CUSTOMER'S USE,  
MUELLER B20200 OR  
APPROVED EQUAL  
(SEE NOTE 3)

### SECTION

NTS

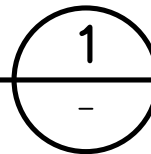

**NOTES:**

1. DO NOT SET REDUCED PRESSURE BACKFLOW PREVENTER (RPBP) ON PRIVATE PROPERTY.
2. IF RPBP IS LOCATED NEAR TRAFFIC AREAS, DWD WILL REQUIRE A MIN OF TWO 4" GALVANIZED STEEL GUARD POSTS TO BE 42" HIGH, EMBEDDED 36" BELOW GROUND IN CONCRETE, AND FILLED WITH CONCRETE.
3. FITTING SHOULD BE DIELECTRIC WHERE JOINING DISSIMILAR METALS.
4. PROTECTIVE ENCLOSURE SHALL BE FOREST GREEN 5. REFER TO SPEC SECTIONS 02210, 02620, 03304, & 15400 FOR FULL DESCRIPTION.
5. CONTRACTOR TO SUPPLY AND INSTALL (4) 1/4" MIP X 1/4" FLARE ADAPTER.

**DIABLO WATER DISTRICT**

STANDARD DRAWING  
**REDUCED PRESSURE  
BACKFLOW PREVENTER INSTALLATION, 3/4" TO 2"**

DESIGNED <u>WDB</u>	DRAWN <u>WKT</u>	APPROVED <u>WW</u>	DATE <u>OCTOBER, 2022</u>	DWG. NO. <b>DWD 11</b>
---------------------	------------------	--------------------	---------------------------	------------------------

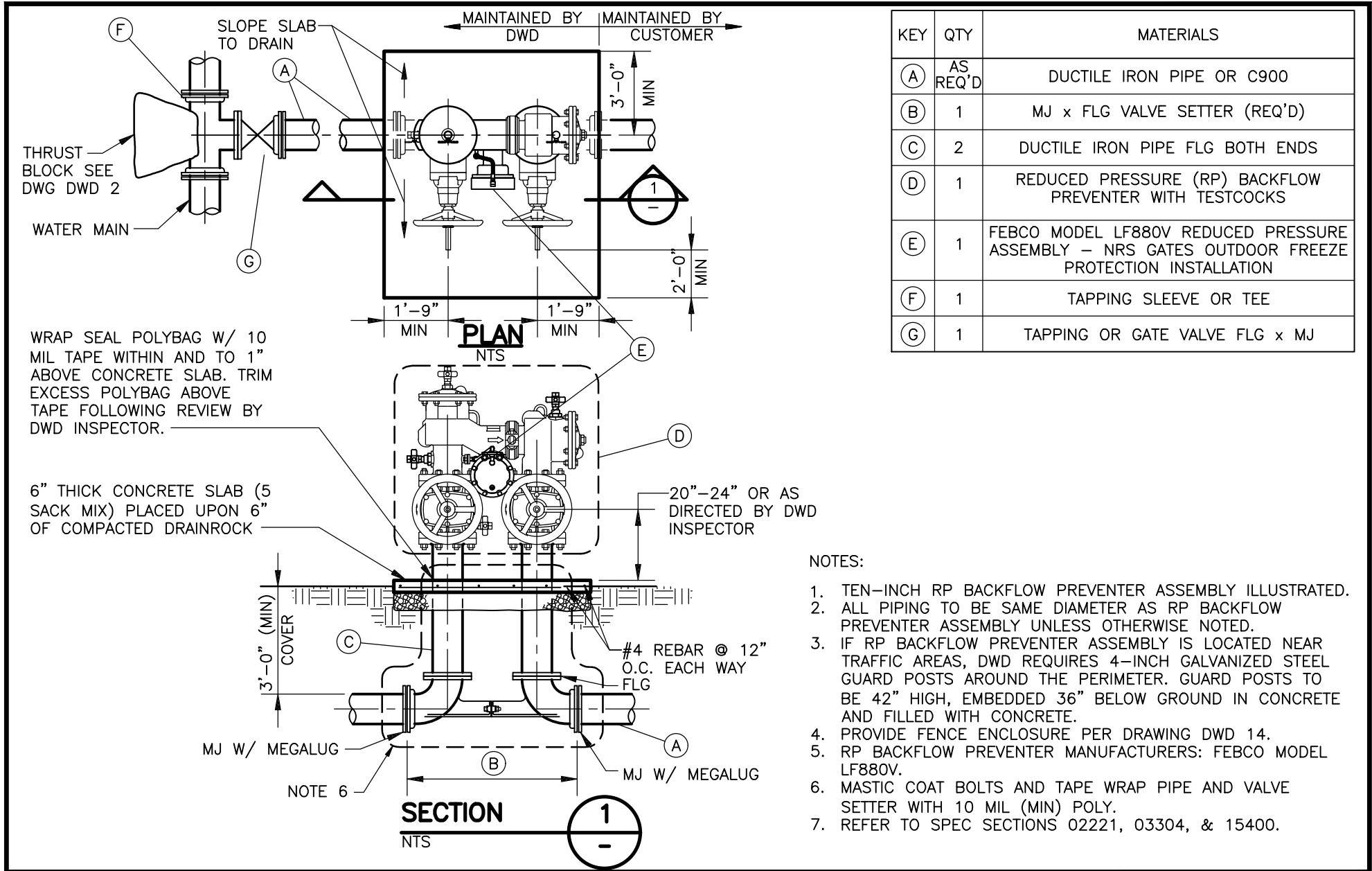

DIABLO WATER DISTRICT

STANDARD DRAWING  
**REDUCED PRESSURE BACKFLOW PREVENTER INSTALLATION,  
 2 1/2" TO 10"**

DESIGNED WDB

DRAWN WKT

APPROVED WW

DATE OCTOBER, 2022

DWG. NO. DWD 12

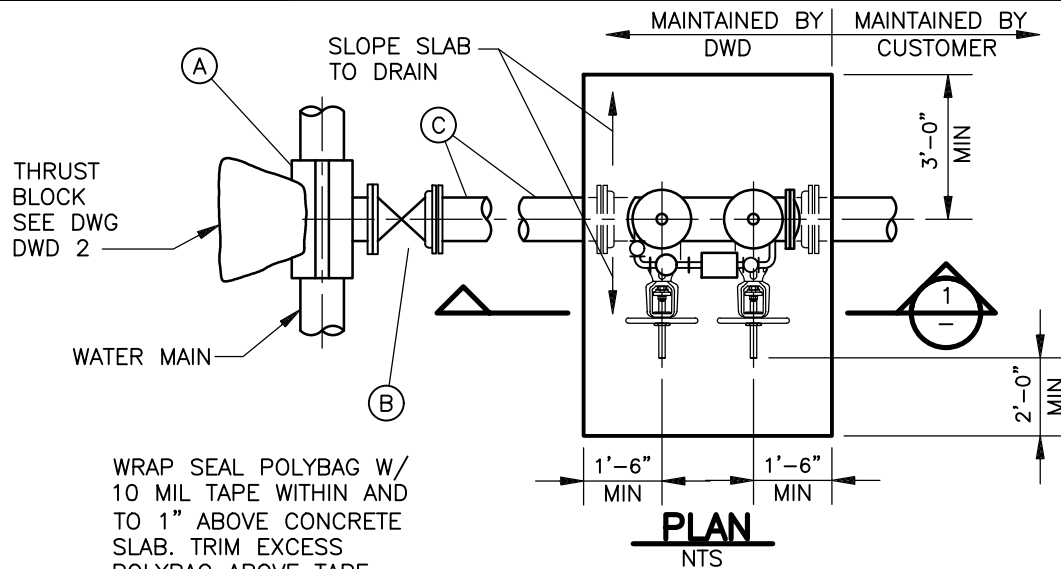

WRAP SEAL POLYBAG W/  
10 MIL TAPE WITHIN AND  
TO 1" ABOVE CONCRETE  
SLAB. TRIM EXCESS  
POLYBAG ABOVE TAPE  
FOLLOWING REVIEW BY  
DWD INSPECTOR.

6" THICK CONCRETE SLAB (5  
SACK MIX) PLACED UPON 6"  
OF COMPACTED DRAINROCK

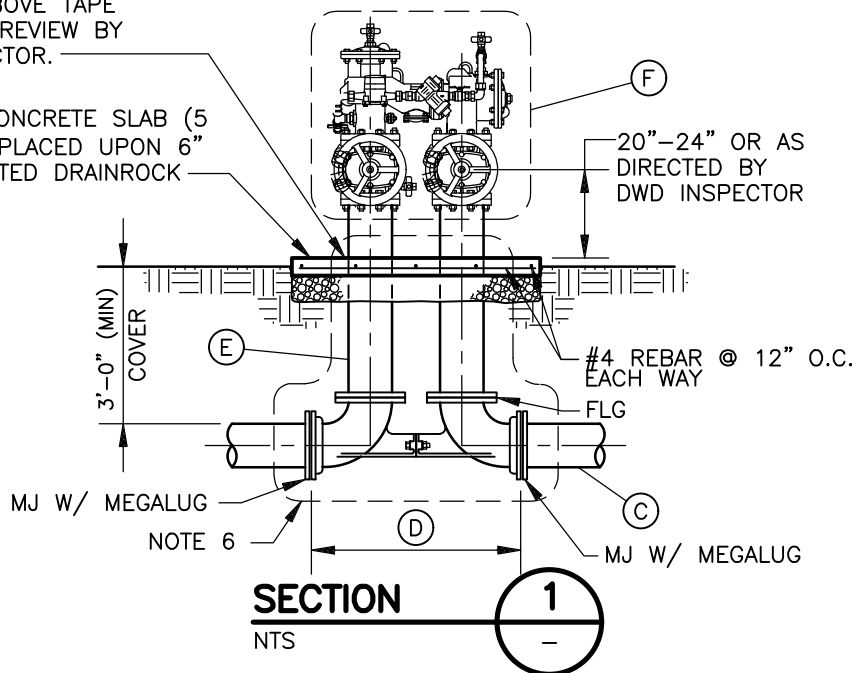

KEY	QTY	MATERIALS
(A)	1	TAPPING SLEEVE OR TEE
(B)	1	TAPPING OR GATE VALVE FLG x MJ
(C)	AS REQ'D	DUCTILE IRON PIPE OR C900
(D)	1	MJ x FLG VALVE SETTER (REQ'D)
(E)	2	DUCTILE IRON PIPE FLG BOTH ENDS
(F)	1	DOUBLE CHECK DETECTOR VALVE WITH TESTCOCKS

NOTES:

1. TEN-INCH DOUBLE CHECK DETECTOR ASSEMBLY ILLUSTRATED.
2. ALL PIPING TO BE SAME DIAMETER AS DETECTOR CHECK VALVES UNLESS OTHERWISE NOTED.
3. INSTALL FOUR BOLLARDS PER DWD 24 AROUND UNIT. LOCATIONS OF BOLLARDS PER DWD INSPECTOR.
4. PROVIDE FENCE ENCLOSURE PER DRAWING DWD-14.
5. DOUBLE CHECK DETECTOR VALVE MANUFACTURER: FEBCO MODEL LF876VST N-SHAPE.
6. MASTIC COAT BOLTS AND TAPE WRAP PIPE AND VALVE SETTER WITH 10 MIL (MIN) POLY.
7. SENSES SR 2 METER WITH 520M FLEXNET MTX UNIT.
8. REFER TO SPEC SECTIONS 02210, 03304, & 15400.
9. INSTALL FREEZE BAG ON COMPLETED VALVE INSTALLATION.

DIABLO WATER DISTRICT

STANDARD DRAWING  
DOUBLE CHECK DETECTOR ASSEMBLY INSTALLATION,  
2-1/2" TO 10"

DESIGNED WDB

DRAWN WKT

APPROVED WW

DATE OCTOBER, 2022

DWG. NO. DWD 13

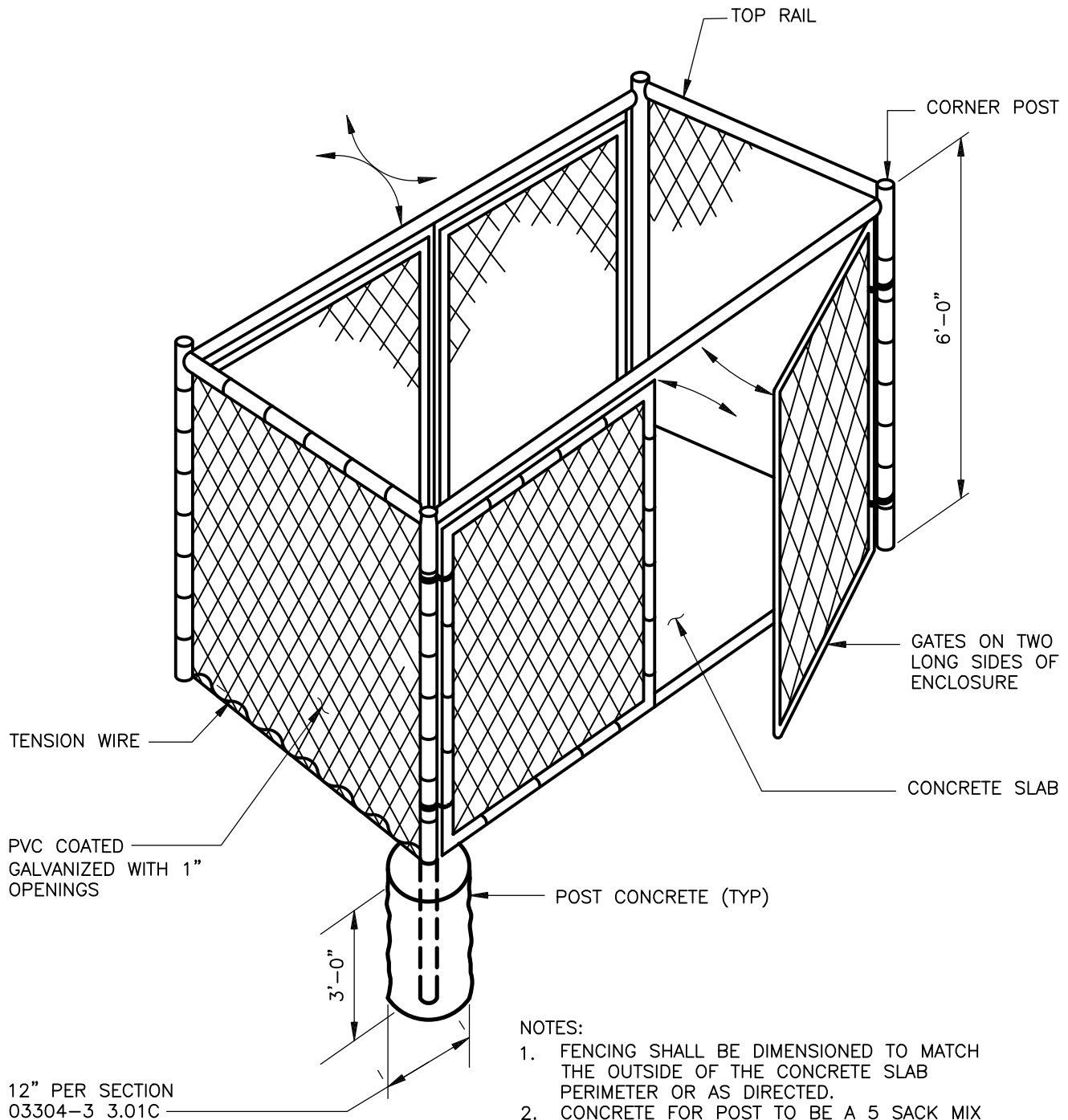

NOTES:

1. FENCING SHALL BE DIMENSIONED TO MATCH THE OUTSIDE OF THE CONCRETE SLAB PERIMETER OR AS DIRECTED.
2. CONCRETE FOR POST TO BE A 5 SACK MIX AND SHALL BE PROPERLY MIXED BEFORE PLACING. DRY CONCRETE MIX SHALL NOT BE PLACED INTO POST HOLES.
3. REFER TO SPEC SECTIONS 02830 & 03304.
4. MESH OPENING TO BE DETERMINED AS PER PROJECT REQUIREMENT.

DIABLO WATER DISTRICT

STANDARD DRAWING  
CHAIN LINK FENCE ENCLOSURE

DESIGNED WDB

DRAWN WKT

APPROVED WW

DATE OCTOBER, 2022

DWG. NO.

**DWD 14**

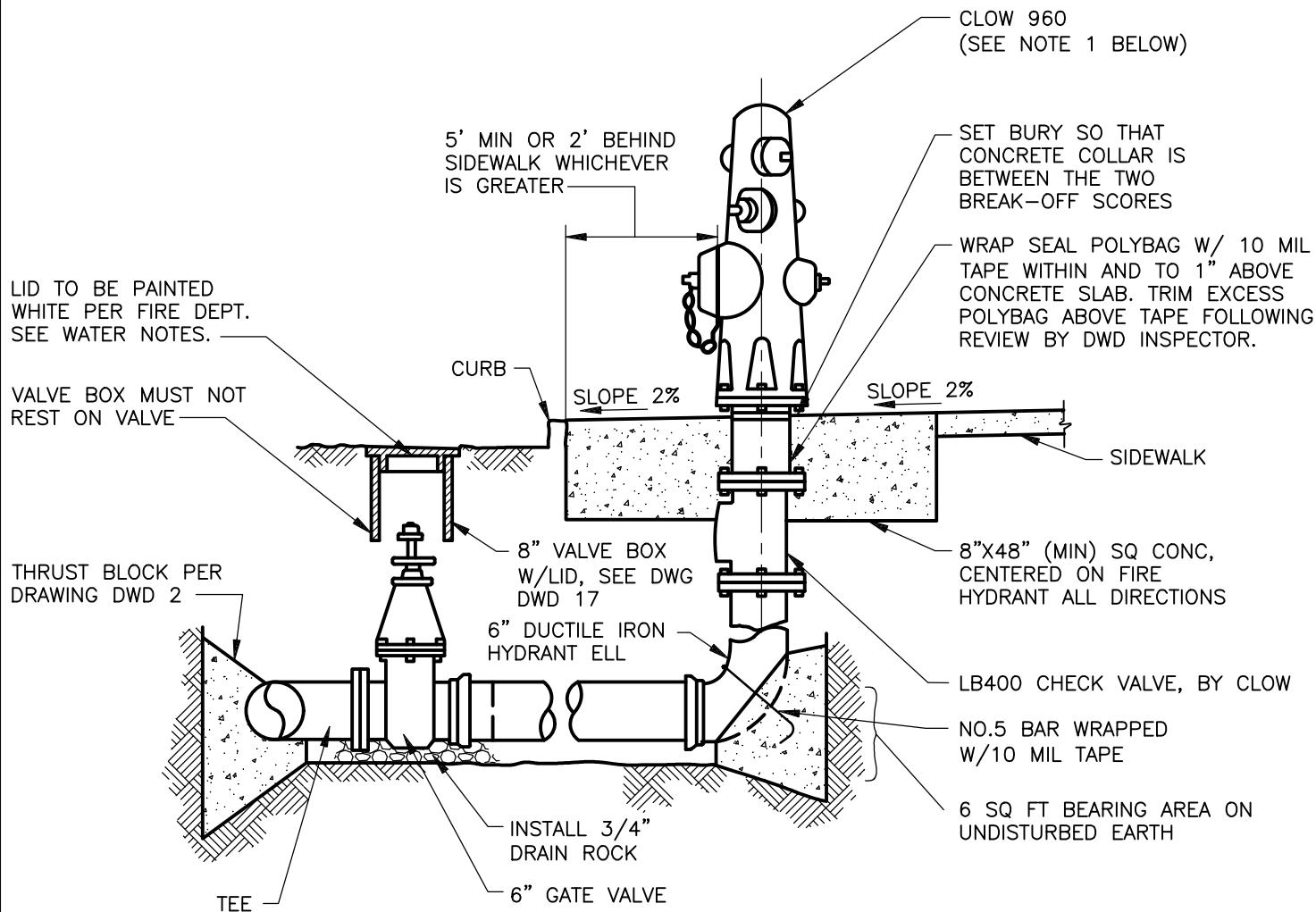

**NOTES:**

1. FIRE HYDRANT AND HYDRANT PIPING CONFIGURATION SHALL CONFORM TO THE REQUIREMENTS OF THE LOCAL FIRE PROTECTION DISTRICT HAVING JURISDICTION.
2. WHEN NO CURB IS PRESENT CONSULT DISTRICT FOR LOCATION OF HYDRANT.
3. USE MEGALUG RESTRAINT WHERE MJ FITTINGS ARE USED.
4. APPLY NSF 61- APPROVED LUBRICANT TO HYDRANT OUTLETS THREADS.
5. REFER TO SPEC SECTIONS 03304 & 15100.

ITEM	PVC PLASTIC MAIN	DUCTILE IRON MAIN
TEE	PUSH-ON x PUSH-ON x FLG	PUSH-ON x PUSH-ON x FLG MJ x MJ x FLG
6" VALVE JOINTS	FLG x PUSH-ON	FLG x PUSH-ON FLG x MJ
PIPE TO HYD ELL	6" PVC	6" DIP
HYD DI BURY	PUSH-ON	PUSH-ON OR MJ

**DIABLO WATER DISTRICT**

STANDARD DRAWING  
**FIRE HYDRANT INSTALLATION**

DESIGNED WDB

DRAWN WKT

APPROVED WW

DATE OCTOBER, 2022

DWG. NO.

**DWD 15**



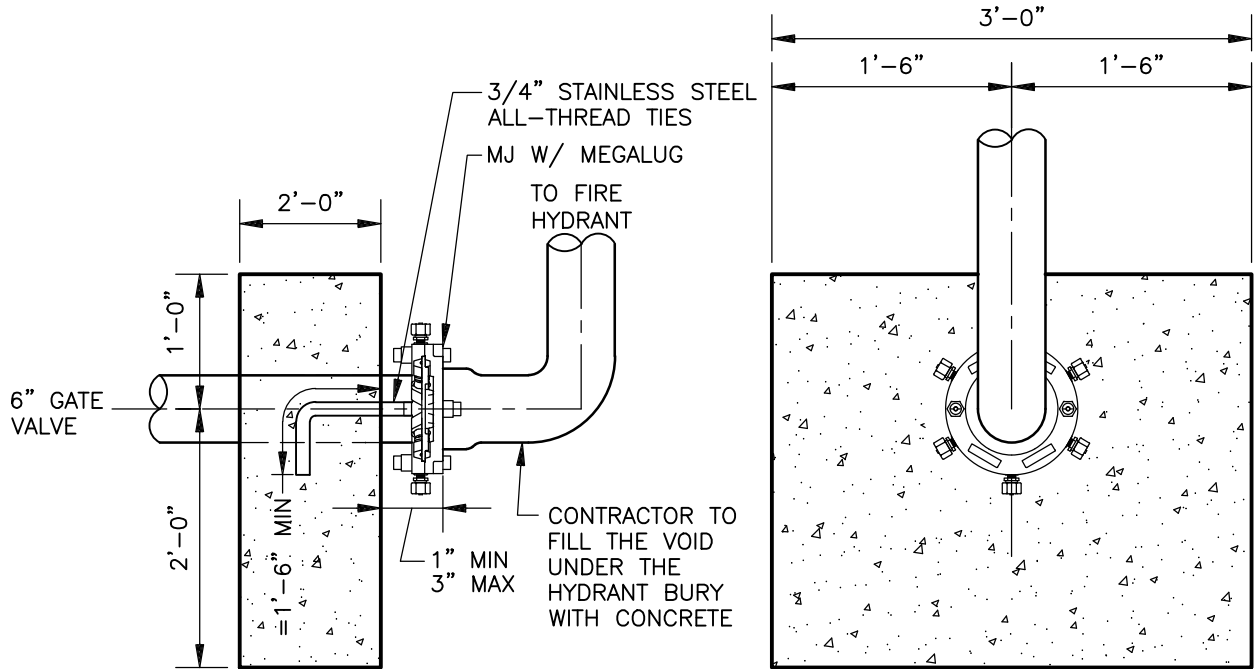

NOTE:  
 PIPING FROM MAIN TO FH WITHIN 6-FT OF EDGE OF SLOPES  
 SHALL BE DIP WITH ALL RESTRAINED JOINTS

DIABLO WATER DISTRICT

STANDARD DRAWING  
 REVERSE THRUST BLOCK AT  
 FIRE HYDRANT ON EMBANKMENT

DESIGNED WDB

DRAWN WKT

APPROVED WW

DATE OCTOBER, 2022

DWG. NO.

**DWD 16**

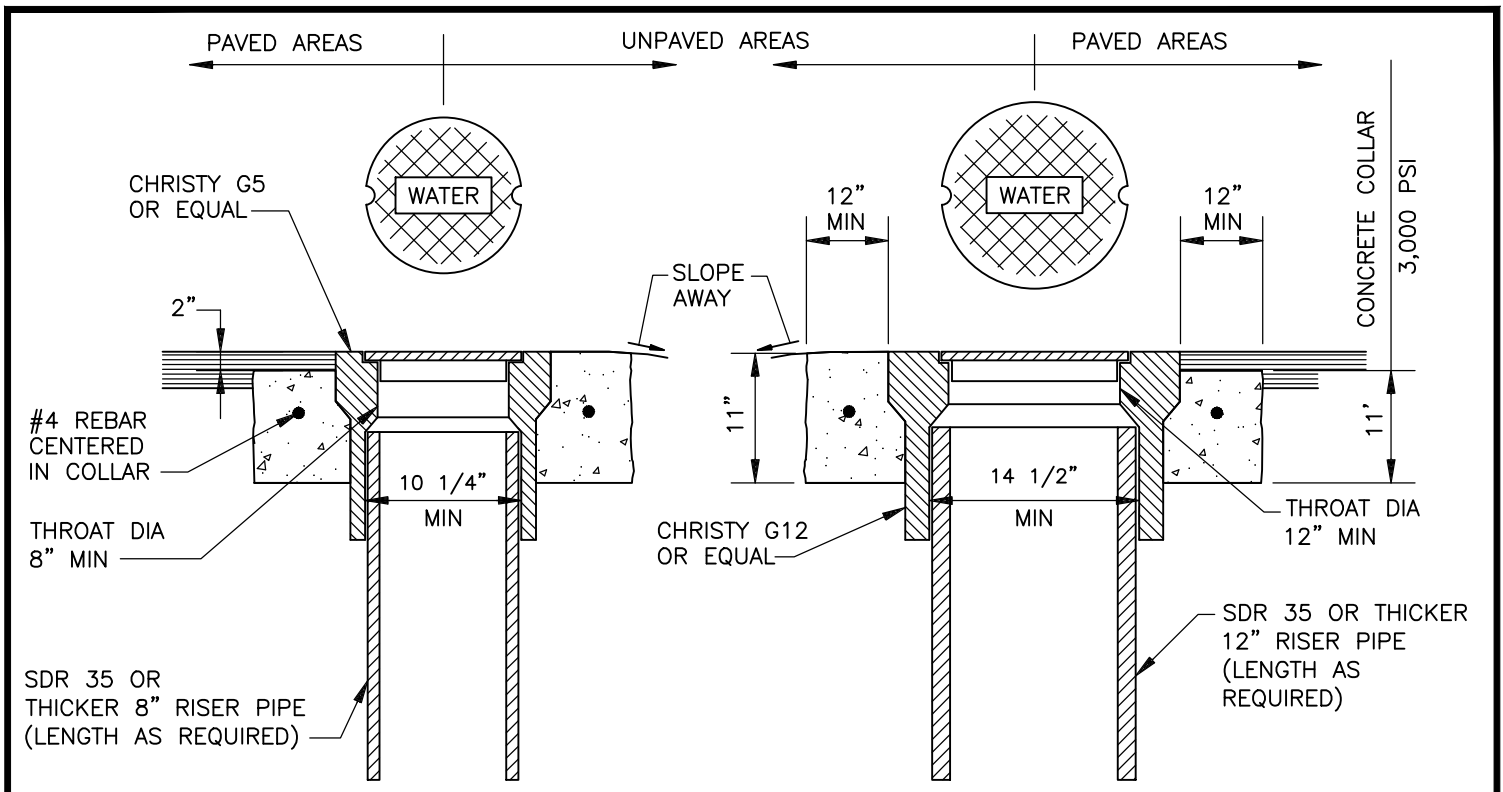

**8" VALVE BOX WITH CAST IRON TRAFFIC LID**

**12" VALVE BOX WITH CAST IRON TRAFFIC LID**

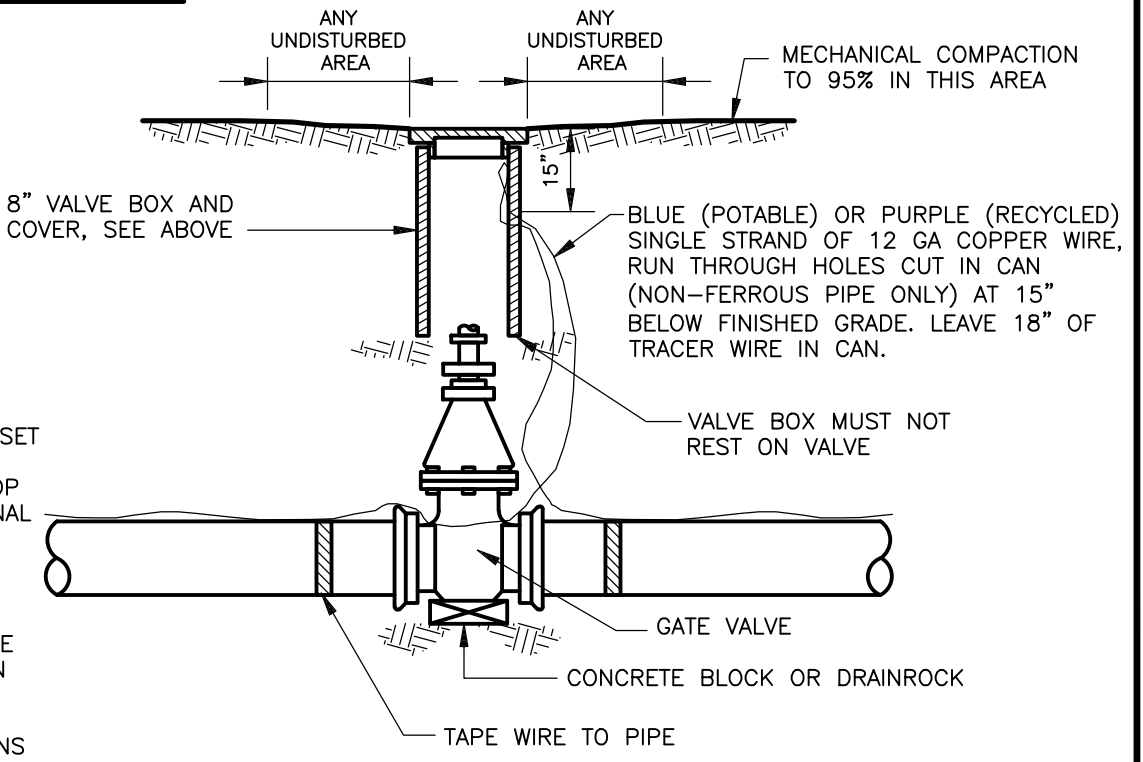

**4" TO 12" GATE VALVE**

**NOTES:**

1. VALVE CANS SHALL BE SET SUCH THAT THEIR TOP WILL BE FLUSH WITH TOP OF PAVEMENT AFTER FINAL PAVING IS COMPLETE.
2. VALVE OPERATING NUTS NOT WITHIN 24" OF FINISHED GRADE REQUIRE A VALVE NUT EXTENSION PER DRAWING DWD 18.
3. REFER TO SPEC SECTIONS 02230, 03304, 15100, & 16640.

<b>DIABLO WATER DISTRICT</b>		<b>STANDARD DRAWING VALVE BOXES, LIDS AND RISER INSTALLATION, 12" AND SMALLER</b>		
DESIGNED <u>WDB</u>	DRAWN <u>WKT</u>	APPROVED <u>WW</u>	DATE <u>OCTOBER, 2022</u>	DWG. NO. <b>DWD 17</b>

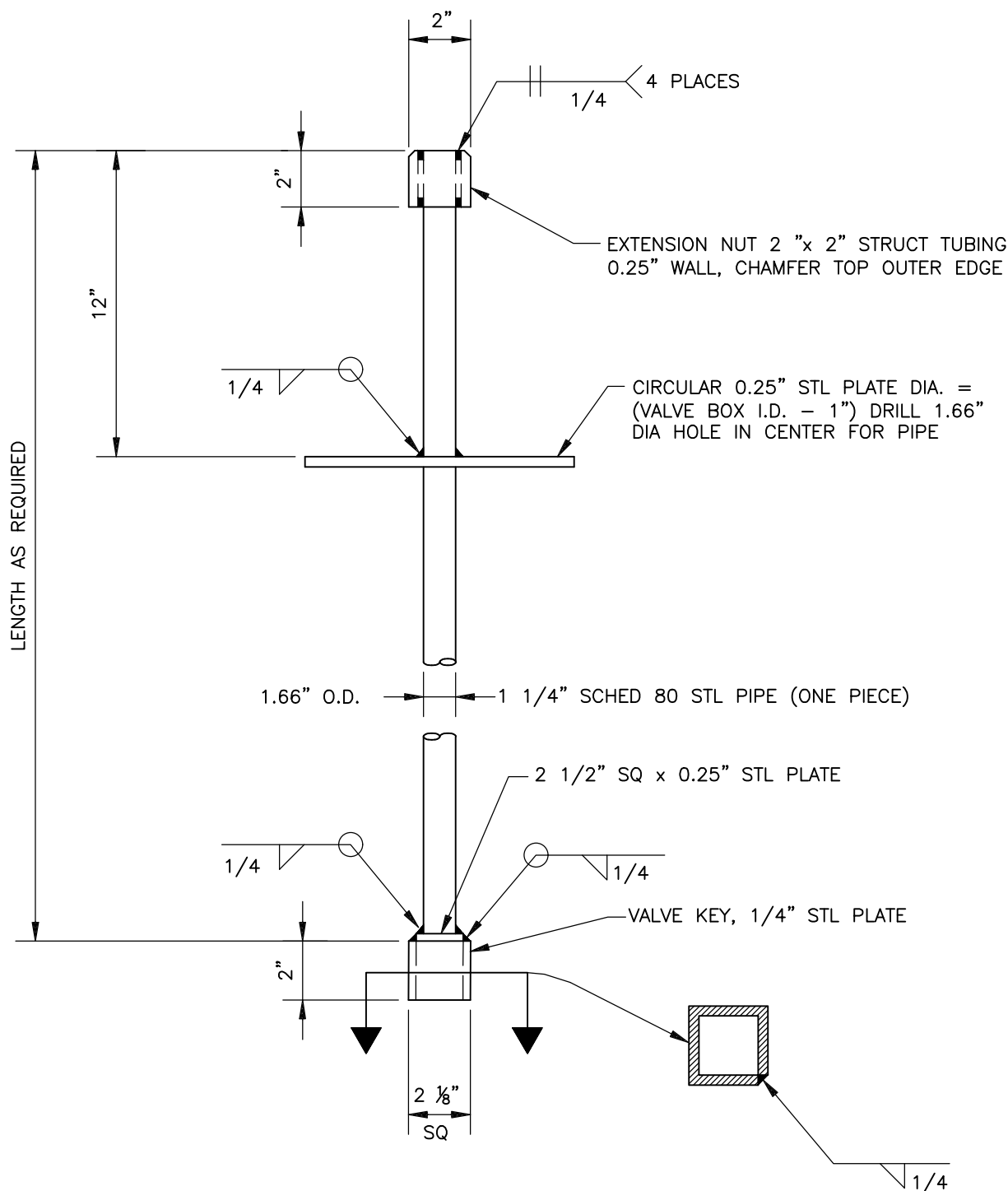

NOTES:

1. LENGTH OF EXTENSION IN INCHES SHALL BE INSCRIBED WITH AN ARC WELD BEAD (MIN 2" IN HEIGHT) ON TOP FACE OF CIRCULAR PLATE.
2. VALVE KEY SHALL FIT OVER STANDARD 2" VALVE OPERATING NUT.
3. EXTENSION NUT AND VALVE KEY TO BE ALIGNMENT WITH EACH OTHER.
4. REFER TO SPEC SECTION 15100.
5. POWDER COATED RED.

DIABLO WATER DISTRICT

STANDARD DRAWING  
VALVE NUT EXTENSION

DESIGNED _____ WDB	DRAWN _____ WKT	APPROVED _____ WW	DATE _____ OCTOBER, 2022	DWG. NO. <b>DWD 18</b>
--------------------	-----------------	-------------------	--------------------------	------------------------

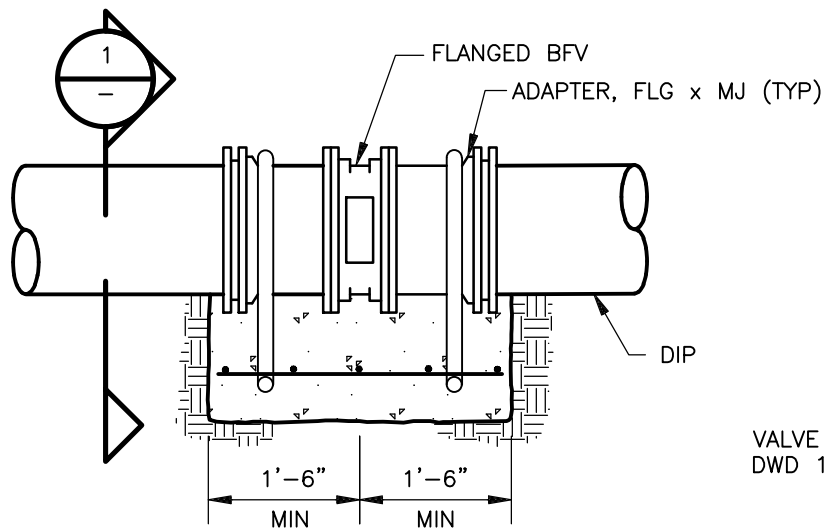

**IN-LINE BFV**

NTS

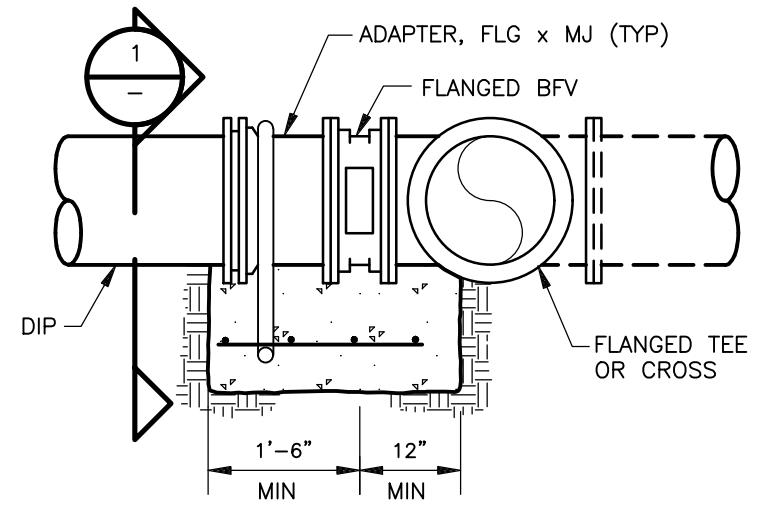

**BFV AT TEE OR CROSS**

NTS

NOTES:

1. ALL REBAR TO HAVE 3" MIN CONCRETE COVER.
2. CONCRETE TO BE PLACED AGAINST UNDISTURBED SOIL OR COMPACTED DRAINROCK.
3. #6 REBAR IS TO BE WRAPPED IN 3M SCOTCHRAP #50 MOULDING TAPE AND COATED WITH BITUMASTIC BEFORE INSTALLATION.
4. REFER TO SPEC SECTIONS 02610, 03304, & 15100.

VALVE BOX SEE DWG DWD 17

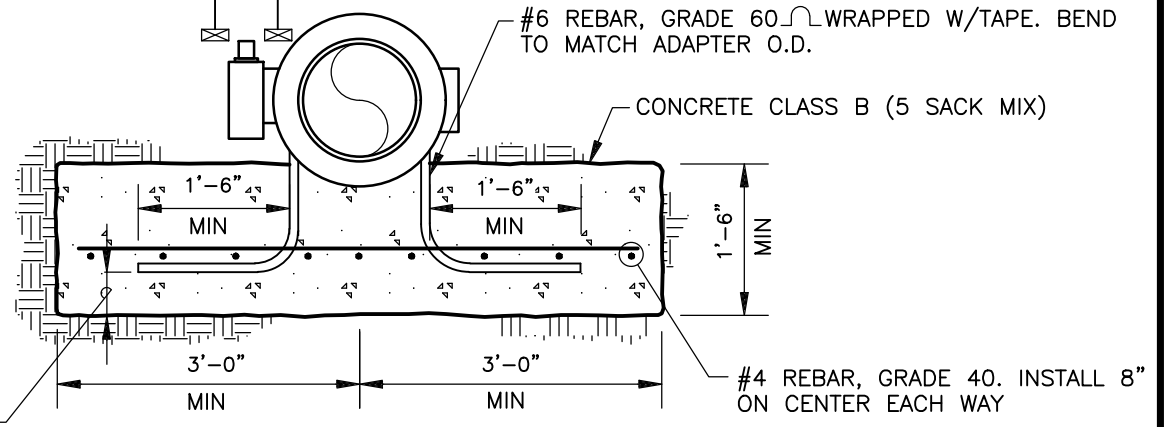

**SECTION**

NTS

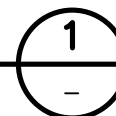

DIABLO WATER DISTRICT

STANDARD DRAWING

BUTTERFLY VALVE INSTALLATION, 16" TO 24"

DESIGNED WDB

DRAWN WKT

APPROVED WW

DATE OCTOBER, 2022

DWG. NO. DWD 19

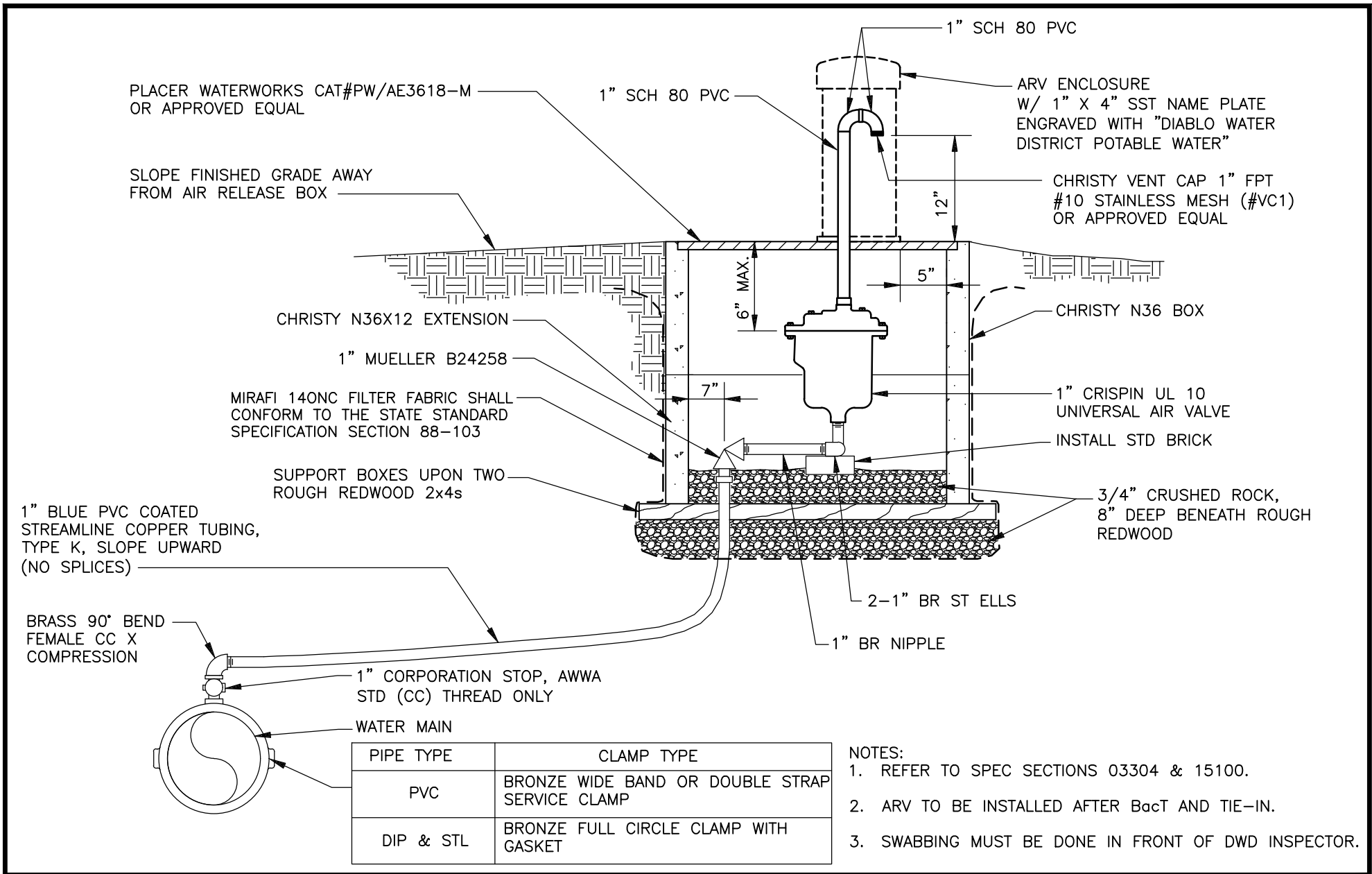

DIABLO WATER DISTRICT

STANDARD DRAWING

1" AIR RELEASE VALVE ASSEMBLY

DESIGNED WDB

DRAWN WKT

APPROVED WW

DATE OCTOBER, 2022

DWG. NO. DWD 20

12" DIA VALVE BOX AND COVER,  
SEE DWG DWD 17

2" PLASTIC CAP

LEAVE 12" OF WIRE IN  
CHRISTY BOX

2" NIPPLE BRASS,  
LENGTH TO PLACE TOP  
END WITHIN 2"-3" OF  
FINISHED GRADE

MUELLER H-14204N QUARTER  
BEND METER COUPLING, BRASS

2" MUELLER B-24286N 300  
BALL ANGLE METER VALVE,  
FIP X METER, OR APPROVED  
EQUAL

2" NIPPLE, BRASS

2" ELL 90°, BRASS

THRUST BLOCK AGAINST  
UNDISTURBED EARTH.  
SIZE TO CONFORM TO  
DRAWING DWD 2

2"x3" NIPPLE, BRASS

SINGLE STRAND OF 12 GA COATED  
COPPER WIRE RUN THROUGH HOLES  
CUT 1" BELOW BOTTOM OF CHRISTY  
BOX (NON FERROUS MAINS ONLY)

TAPE WIRE TO  
TOP OF PIPE

WATER MAIN

CAP W/2" TAP AT INVERT

NOTES:

1. REFER TO SPEC SECTIONS 02620, 03304, 15100, & 16640.

DIABLO WATER DISTRICT

STANDARD DRAWING

2" BLOWOFF ASSEMBLY

DESIGNED WDB

DRAWN E.P.M

APPROVED WW

DATE OCTOBER, 2022

DWG. NO.

DWD 21

12" VALVE BOX ASSEMBLY  
SEE DWG DWD 17

8" VALVE BOX ASSEMBLY  
SEE DWG DWD 17

4" GALV PLUG WITH 2" NUT  
THREAD, HAND TIGHT ONLY.  
TOP OF PLUG TO BE 6" TO 9"  
BELOW FINISHED GRADE

4" DIP WITH GALV  
COMPANION FLANGE,  
LENGTH AS REQUIRED

THRUST BLOCK PER  
DWG DWD 2

4" GATE VALVE, FLG.

MJ X FLANGE DIP  
ADAPTER

MJ W/ MEGALUG

WATER MAIN

FLANGED REDUCER

4" DIP SPOOL, MIN 8" LONG

4" LONG RADIUS 90° ELL, FLG

NOTES:

1. INSTALLATION AS SHOWN IS FOR 4" BLOWOFF. INCREASE PIPES AND VALVES FOR LARGER INSTALLATIONS.
2. PIPING ASSEMBLY SHALL BE WRAPPED IN POLYETHYLENE PRIOR TO PLACING CONCRETE.
3. REFER TO SPEC SECTIONS 02610, 03304, 15100, & 16640.

DIABLO WATER DISTRICT

STANDARD DRAWING

4", 6", & 8" BLOWOFF ASSEMBLY

DESIGNED WDB

DRAWN WKT

APPROVED WW

DATE OCTOBER, 2022

DWG. NO.

DWD 22

CONC METER BOXES, MIN ID OF 14"x23", WITH ONE PIECE CONC COVER. TRAFFIC COVER REQUIRED IF LOCATED IN TRAFFIC AREA. CUT OUT BOX AROUND PIPING AS REQ'D

SLOPE FINISHED GRADE AWAY FROM AIR RELEASE BOX

CHRISTY N-30 WITH EXTENSION

1" MUELLER B24258

SUPPORT BOXES UPON TWO ROUGH REDWOOD 2x4s

1" BLUE PVC COATED STREAMLINE COPPER TUBING, TYPE K, SLOPE UPWARD

BRASS 90° BEND FEMALE CC X COMPRESSION

1" CORPORATION STOP, AWWA STD (CC) THREAD ONLY

WATER MAIN

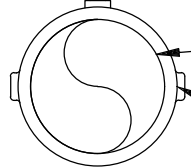

PIPE TYPE	CLAMP TYPE
PVC	BRONZE WIDE BAND OR DOUBLE STRAP SERVICE CLAMP
DIP & STL	BRONZE FULL CIRCLE CLAMP WITH GASKET

2" GALV NIPPLE (TYP)

GALV ST ELL, NIPPLE, & UNION. SIZE TO MATCH AIR RELEASE OUTLET, 1/2" MIN

1" AIR RELEASE VALVE

2" GALV ELL & ST ELL

NORTHTOWN HYTECH STAINLESS STL SCREEN & HOSE CLAMP OVER 2" GALV NIPPLE

12" MIN

2" GALV RED TEE

WRAPPED IN 10 MIL TAPE

2" GALV PIPE, MIN 24" LONG

CLASS B CONCRETE (5 SACK MIX)

2" GALV CAP

4" MIN

12" DIA MIN

2-1" BR ST ELLS

1" BR NIPPLE

3/4" CRUSHED ROCK,

NOTE:  
1. REFER TO SPEC SECTIONS 03304 & 15100.

DIABLO WATER DISTRICT

STANDARD DRAWING

ALTERNATE 1" AIR RELEASE VALVE ASSEMBLY

DESIGNED WDB

DRAWN WKT

APPROVED WW

DATE OCTOBER, 2022

DWG. NO. DWD 23



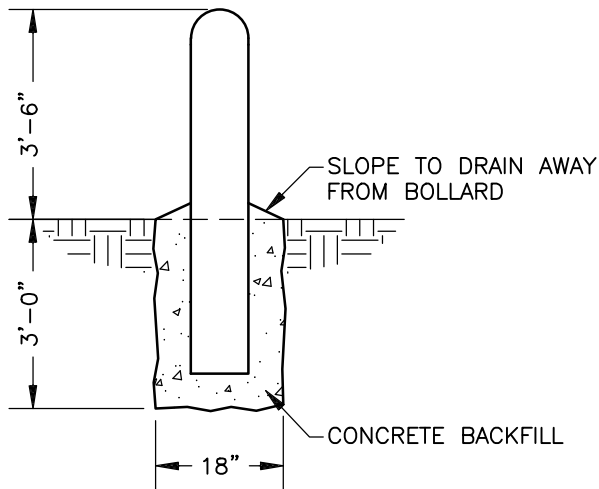
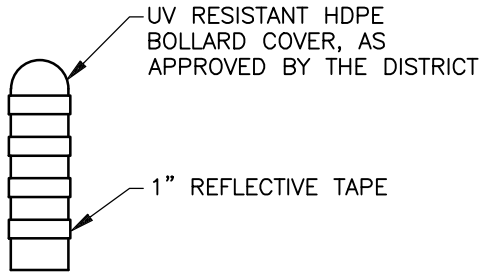

NOTES:

1. 4" G.I.P. FILLED WITH CONCRETE.
2. 1" WIDE SILVER AND RED REFLECTIVE TAPE @ 6" O.C.
3. CONSULT WITH DWD INSPECTOR PRIOR TO INSTALLATION.

**BOLLARD DETAILS**

NTS

DIABLO WATER DISTRICT

STANDARD DRAWING  
**BOLLARD INSTALLATION**

DESIGNED WDB

DRAWN WKT

APPROVED WW

DATE OCTOBER, 2022

DWG. NO. **DWD 24**

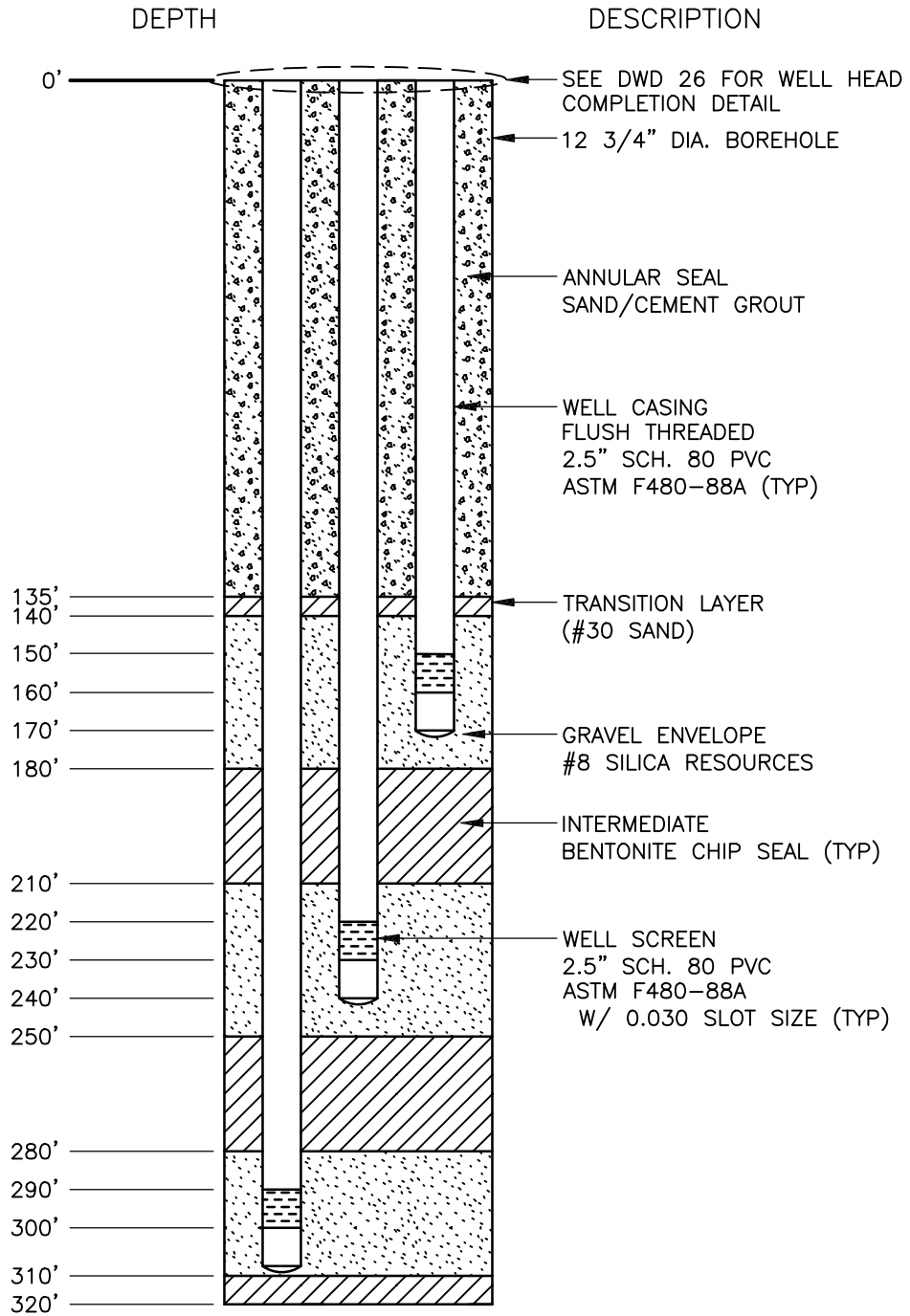

NOT FOR CONSTRUCTION  
FOR ILLUSTRATIVE PURPOSES  
ONLY

DIABLO WATER DISTRICT

STANDARD DRAWING  
CONCEPTUAL MONITORING  
WELL PROFILE

DESIGNED ASL

DRAWN ABC

APPROVED WW

DATE OCTOBER, 2022

DWG. NO.

DWD 25

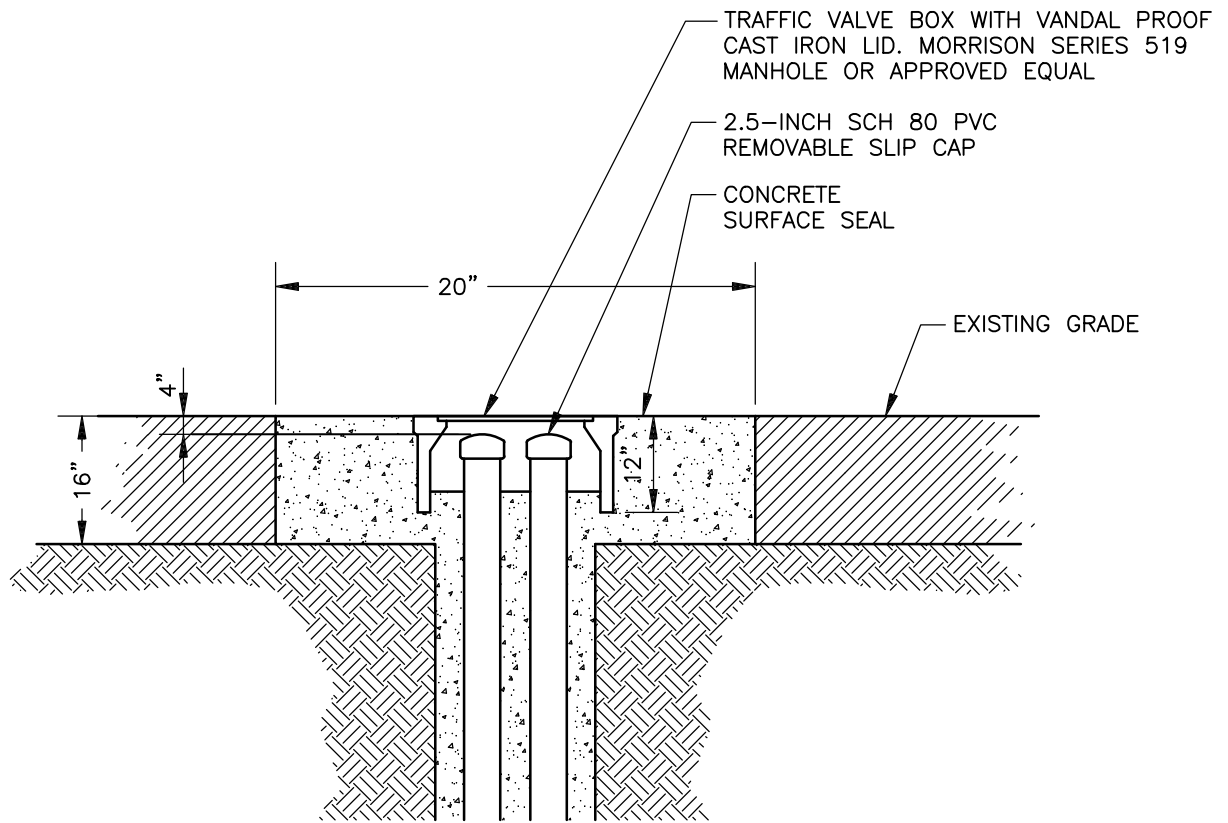

NOTES:

1. TWO WELL HEADS SHOWN FOR ILLUSTRATIVE PURPOSES ONLY. ADDITIONAL WELL HEADS MAY BE REQUIRED.

DIABLO WATER DISTRICT

STANDARD DRAWING  
TYPICAL MONITORING WELL  
FLUSH MOUNT SURFACE COMPLETION

DESIGNED ASL

DRAWN ABC

APPROVED WW

DATE OCTOBER, 2022

DWG. NO. DWD 26

## **7. Cathodic Protection System Drawings**

**DIABLO WATER DISTRICT  
STANDARD SPECIFICATIONS AND DRAWINGS**

**CATHODIC PROTECTION SYSTEM DRAWINGS**

DWD C0	Quick Reference Guide – Cathodic Protection
DWD C1	Wenner Four Pin Resistivity Test
DWD C2	Barnes Layer Resistivity Calculations
DWD C3	Soil Box Resistivity Test
DWD C4	Bond Cables – Metallic Pipe Joints Sacrificial Anode Systems
DWD C5	Bond Cables – Across Fittings on Metallic Pipe
DWD C6	Exothermic Weld
DWD C7	Pin Brazed Connection
DWD C8	Flush Grade Test Station
DWD C9	CTS – Corrosion Test Station
DWD C10	IJTS – Insulating Joint Test Station
DWD C11	FPTS – Foreign Pipeline Test Station
DWD C12	ATS – Anode Test Station
DWD C13	CATS – Casing Anode Test Station
DWD C14	VATS – Valve Anode Test Station
DWD C15	VATS – Valve and Tee Anode Test Station
DWD C16	FHATS – Fire Hydrant Anode Test Station
DWD C17	Metallic Riser Anode Test Station
DWD C18	Cross and Valves Anode Test Station
DWD C19	Elbow Anode Test Station
DWD C20	Double Detector Check Assembly Preventer or Reduced Pressure Backflow Preventer Anode Test Station
DWD C21	Double Offset Anode Test Station
DWD C22	Tapping Saddle Anode Test Station
DWD C23	Cable Identification
DWD C24	Anode at Leak Repair Clamp
DWD C25	Insulating Flange Assembly
DWD C26	Copper Water Laterals Anode Installation
DWD C27	2” Blow Off Anode Installation
DWD C28	Thrust Restraint Harness Anode Installation
DWD C29	Cable Splice Detail
DWD C30	Anode at Tapping Saddle
DWD C31	Galvanic Cathodic Protection System Checkout
DWD C32	Impressed Current Cathodic Protection System Checkout (page 1)
DWD C33	Impressed Current Cathodic Protection System Checkout (page 2)
DWD C34	Leak Repair Report

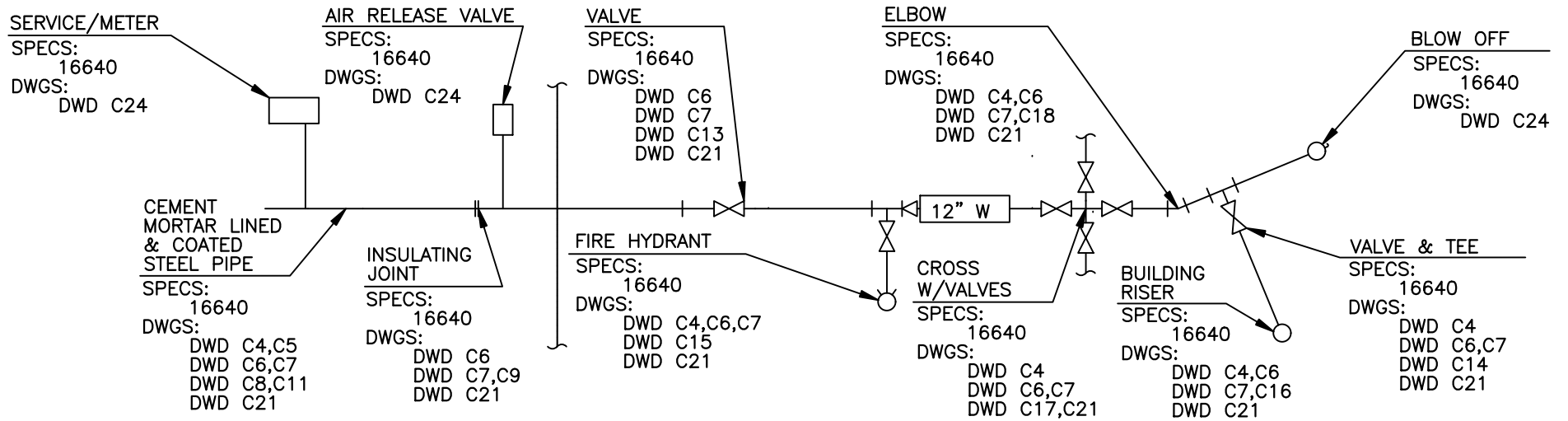

**PLAN**  
 NTS

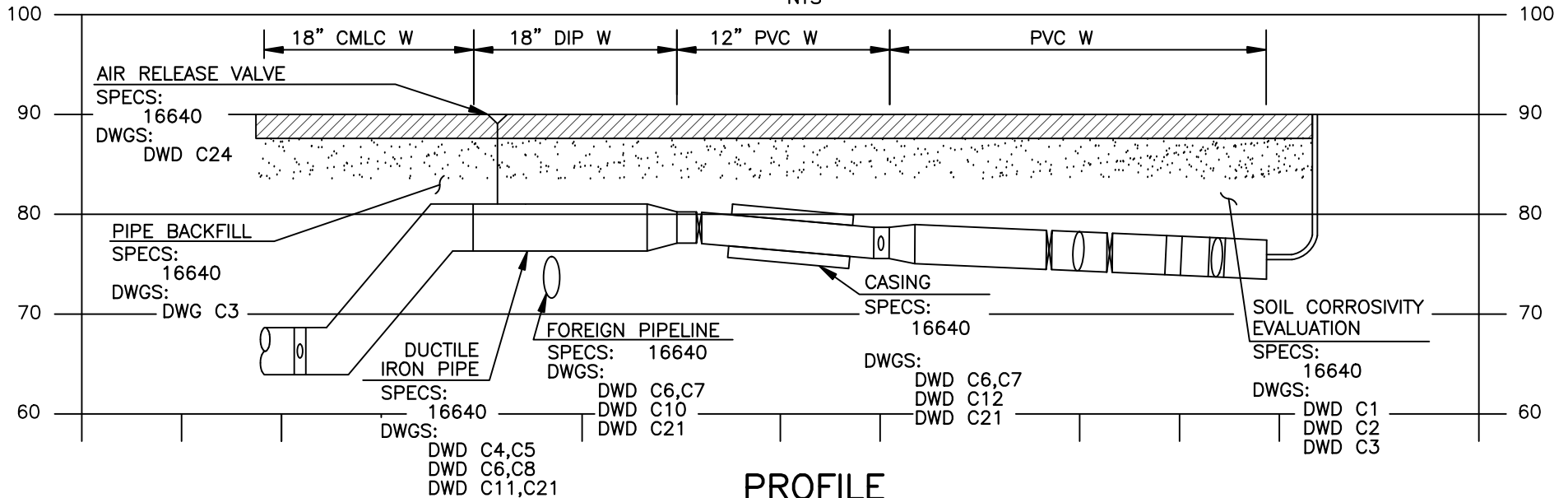

**PROFILE**  
 NTS

DIABLO WATER DISTRICT

STANDARD DRAWING

QUICK REFERENCE GUIDE – CATHODIC PROTECTION

DESIGNED MA DRAWN TH/JAW APPROVED WW DATE OCTOBER, 2022 DWG. NO. DWD CO

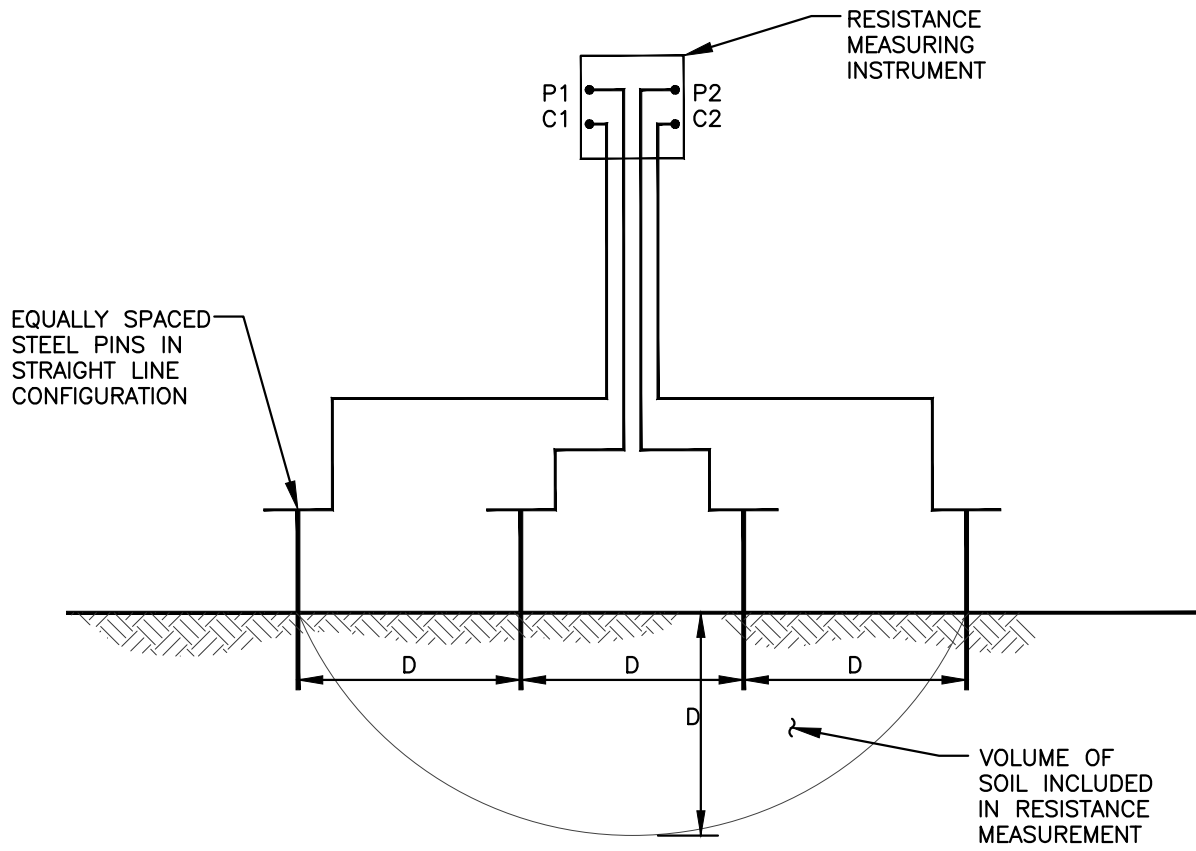

WHERE D=SAMPLE DEPTH.

DIABLO WATER DISTRICT

STANDARD DRAWING  
WENNER FOUR PIN RESISTIVITY TEST

DESIGNED MA

DRAWN SC

APPROVED JDH

DATE OCTOBER 2022

DWG. NO. DWD C1

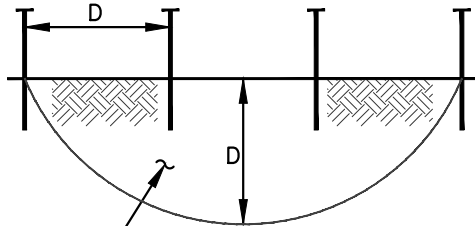

VOLUME OF SOIL  
WITH RESISTANCE R  
AND RESISTIVITY RHO

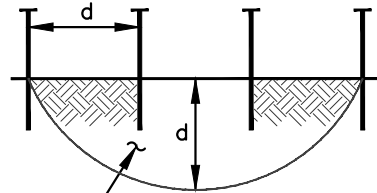

VOLUME OF SOIL  
WITH RESISTANCE r  
AND RESISTIVITY rho

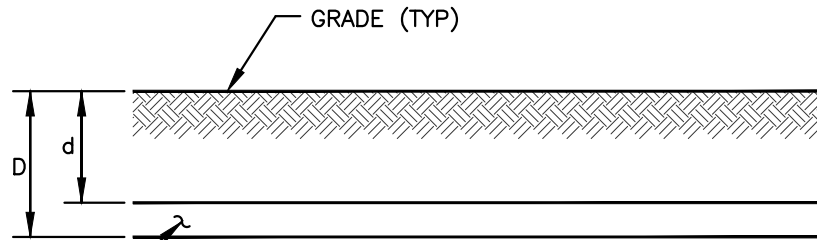

LAYER OF SOIL  
WITH RESISTIVITY =  $\frac{1}{\frac{1}{R} - \frac{1}{r}}$  X (SPACING FACTOR)

DIABLO WATER DISTRICT

STANDARD DRAWING  
BARNES LAYER RESISTIVITY CALCULATIONS

DESIGNED MA

DRAWN SC

APPROVED JDH

DATE OCTOBER 2022

DWG. NO. DWD C2



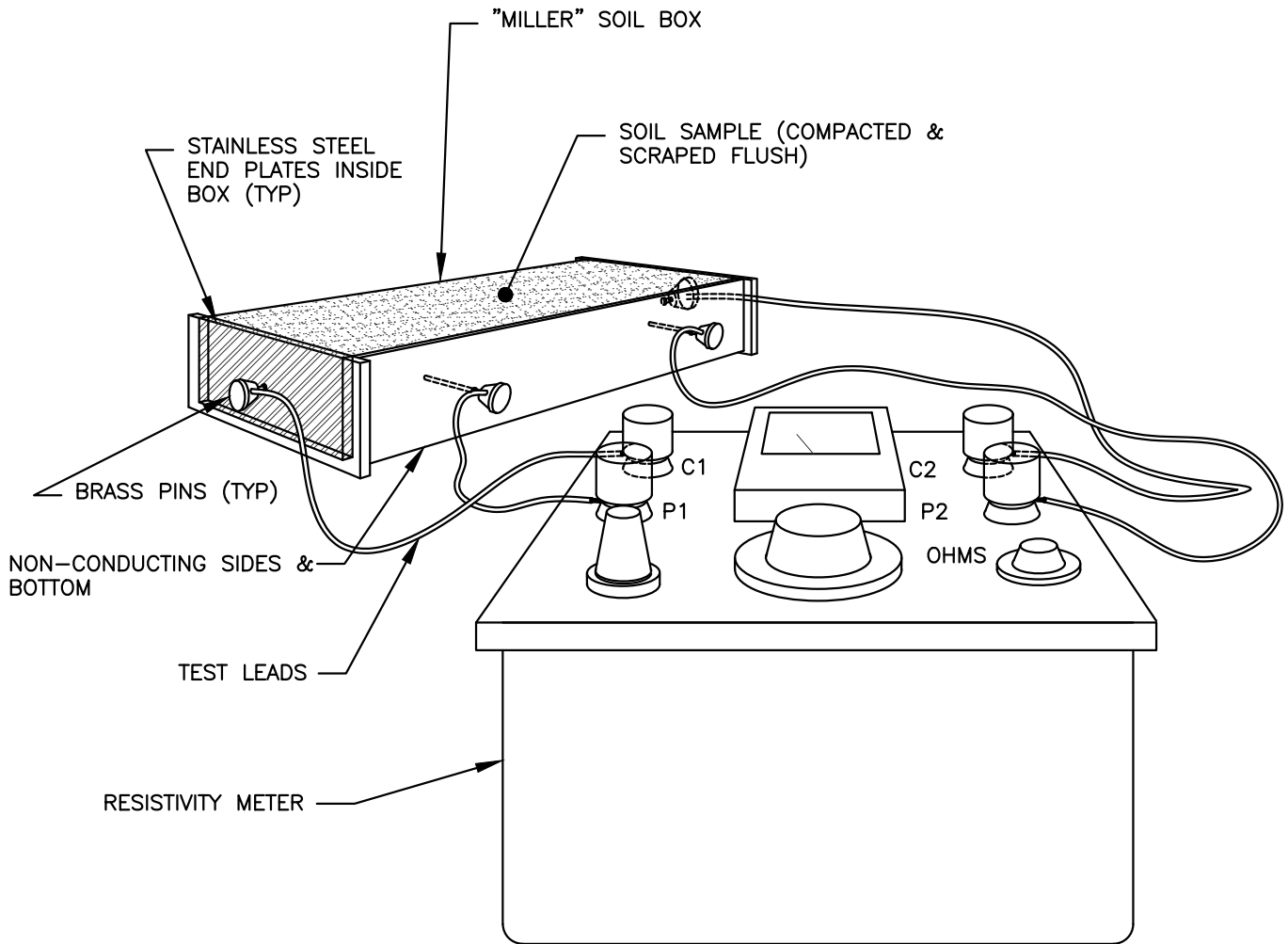

DIABLO WATER DISTRICT

STANDARD DRAWING  
SOIL BOX RESISTIVITY TEST

DESIGNED MA

DRAWN SC

APPROVED JDH

DATE OCTOBER 2022

DWG. NO.

DWD C3

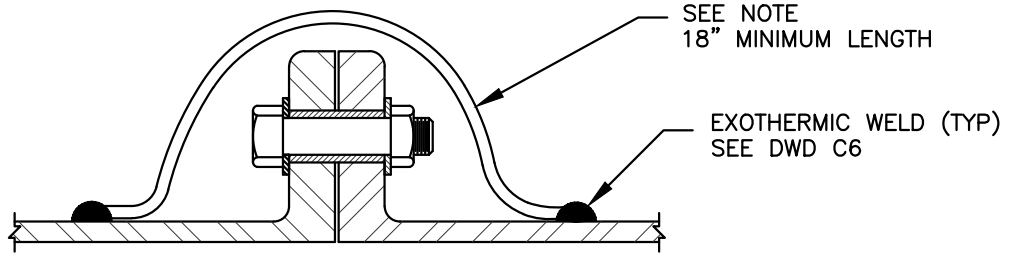

**FLANGED JOINT**

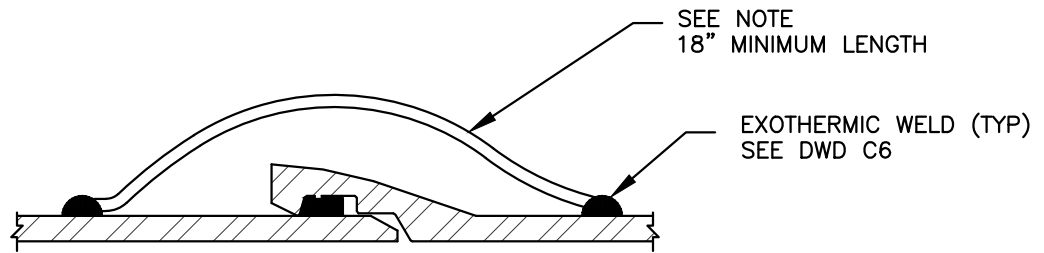

**PUSH-ON JOINT**

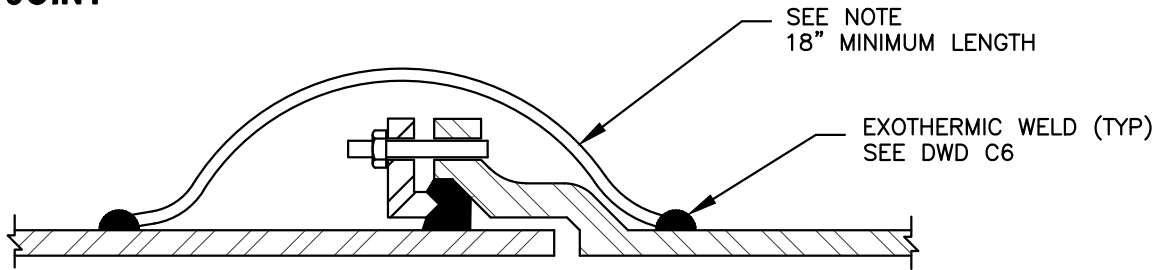

**MECHANICAL JOINT**

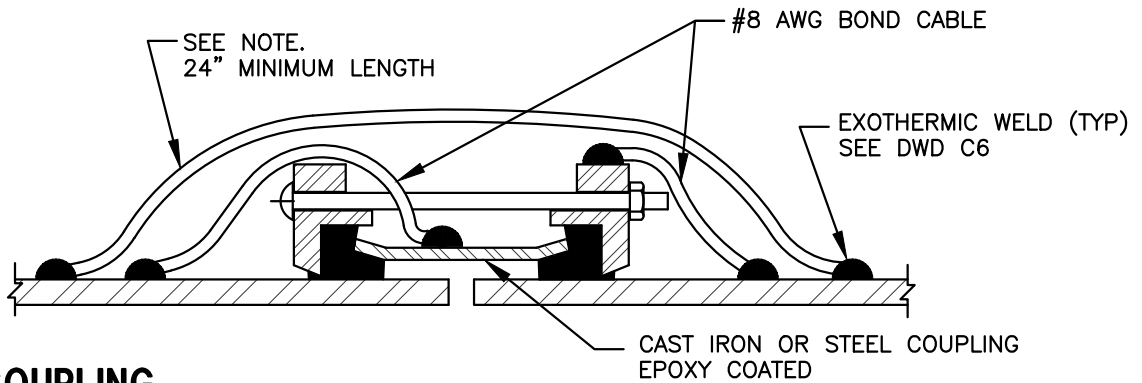

**FLEXIBLE COUPLING**

**NOTES:**

1. USE #8 AWG/HMWPE BOND CABLES FOR BONDING METALLIC FITTINGS ON NONMETALLIC PIPING SYSTEMS.
2. USE #4 AWG/HMWPE BOND CABLES FOR BONDING PIPE JOINTS ON METALLIC PIPING SYSTEMS PER SPECIFICATIONS.

<b>DIABLO WATER DISTRICT</b>		STANDARD DRAWING <b>BOND CABLES - METALLIC PIPE JOINTS SACRIFICIAL ANODE SYSTEMS</b>			
DESIGNED <u>MA</u>	DRAWN <u>SC</u>	APPROVED <u>JDH</u>	DATE <u>OCTOBER 2022</u>	DWG. NO. <b>DWD C4</b>	

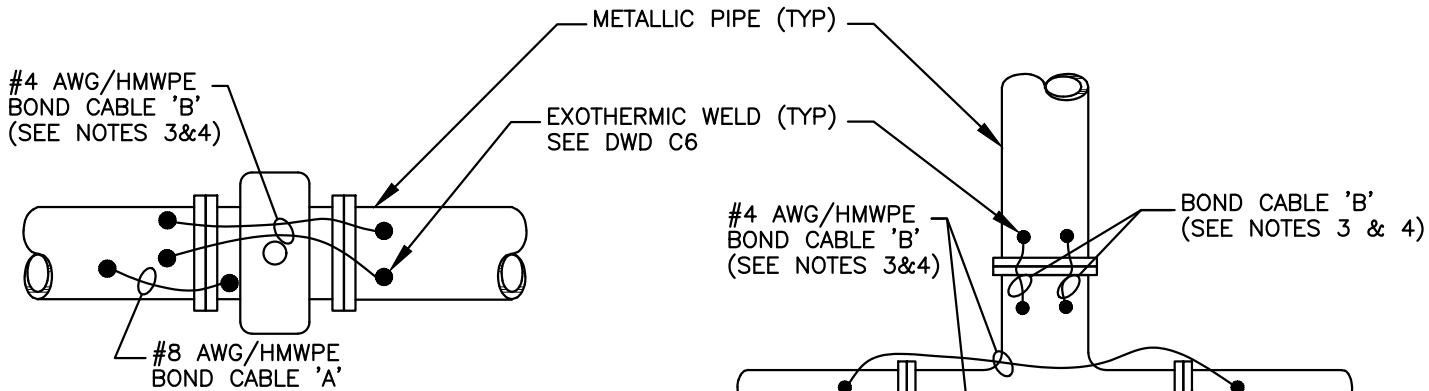

**VALVE**

**TEE**

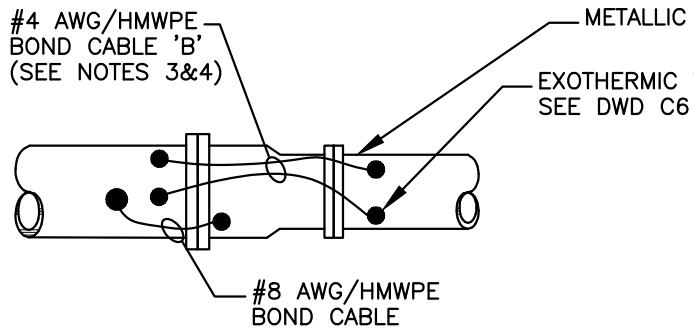

**ADAPTER**

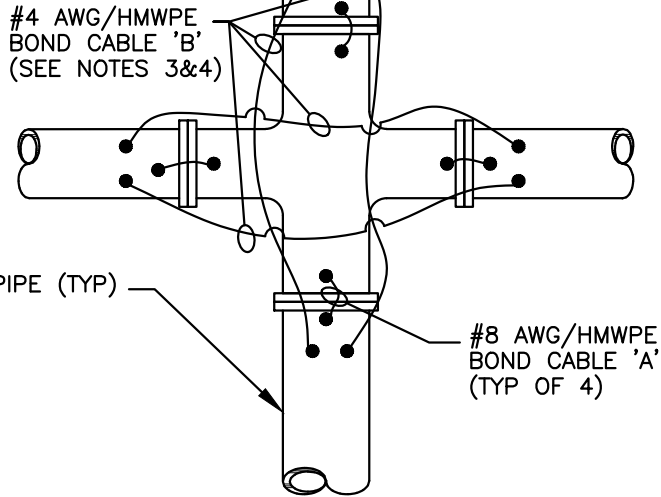

**CROSS**

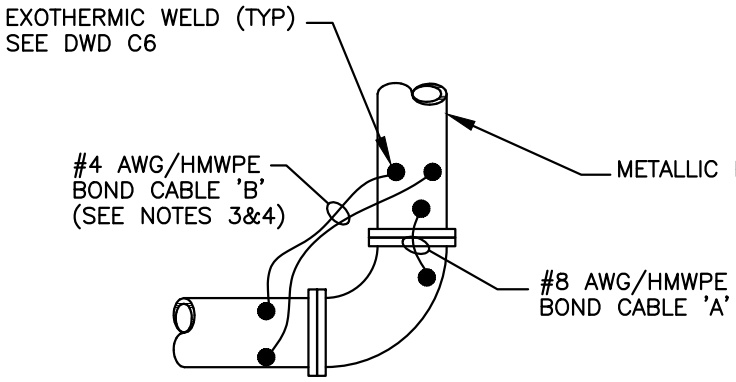

**ELBOW**

**NOTES:**

1. ALL BOND 'B' WIRES SHALL BE #4 AWG/HMWPE STRANDED COPPER WIRE.
2. ALL FITTING BOND WIRES 'A' SHALL BE #8 AWG/HMWPE STRANDED COPPER WIRE.
3. USE ONE (1) BOND CABLE 'B' ACROSS EACH FITTING FOR PIPE SIZES 18" IN DIAMETER OR SMALLER.
4. USE TWO (2) BOND CABLES 'B' ACROSS EACH FITTING FOR PIPE SIZES 20" IN DIAMETER OR LARGER.

<b>DIABLO WATER DISTRICT</b>		<b>STANDARD DRAWING BOND CABLES - ACROSS FITTINGS ON METALLIC PIPE</b>		
DESIGNED <u>MA</u>	DRAWN <u>SC</u>	APPROVED <u>JDH</u>	DATE <u>OCTOBER 2022</u>	DWG. NO. <b>DWD C5</b>

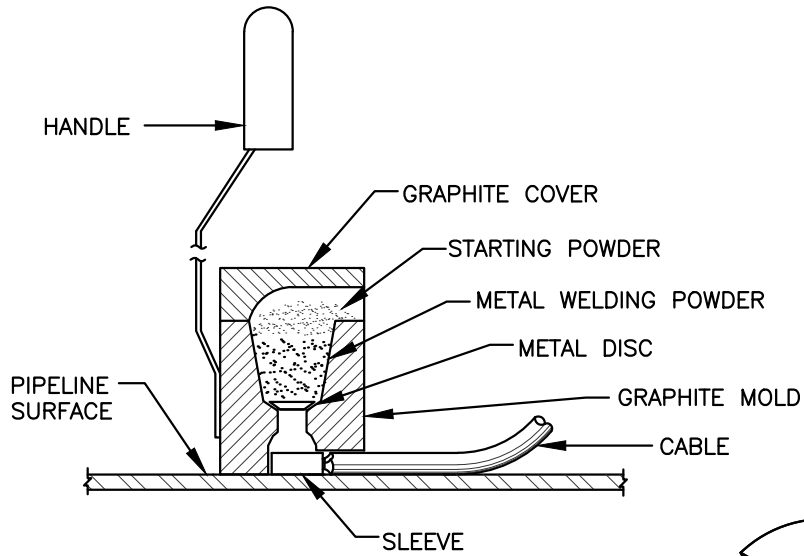

**STEP 1.**

FILE STRUCTURE CONNECTION AREA TO BARE SHINY METAL AND CLEAN.

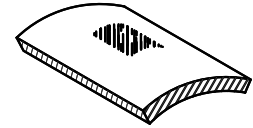

**STEP 2.**

STRIP INSULATION FROM WIRE. ATTACH SLEEVE REQUIRED ON #6 AWG WIRE OR SMALLER

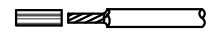

**STEP 3.**

HOLD MOLD FIRMLY WITH OPENING AWAY FROM OPERATOR AND IGNITE WITH FLINT GUN.

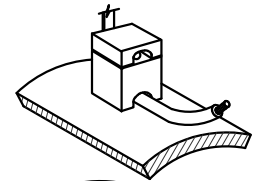

**STEP 4.**

REMOVE SLAG FROM CONNECTION AND PEEN WELD FOR SOUNDNESS.

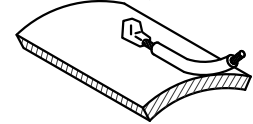

**STEP 5.**

SPRAY PRIMER ON BARE METAL.

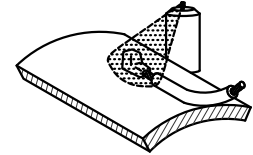

**STEP 6.**

COVER CONNECTION AND EXPOSED STRUCTURE SURFACE WITH PLASTIC CAP & BITUMASTIC



NOTE:  
PROCEDURE SHOWN ABOVE IS TO BE USED AS A GENERAL GUIDE ONLY.  
CONSULT MANUFACTURER'S LITERATURE FOR SPECIFIC INSTALLATION INSTRUCTIONS.

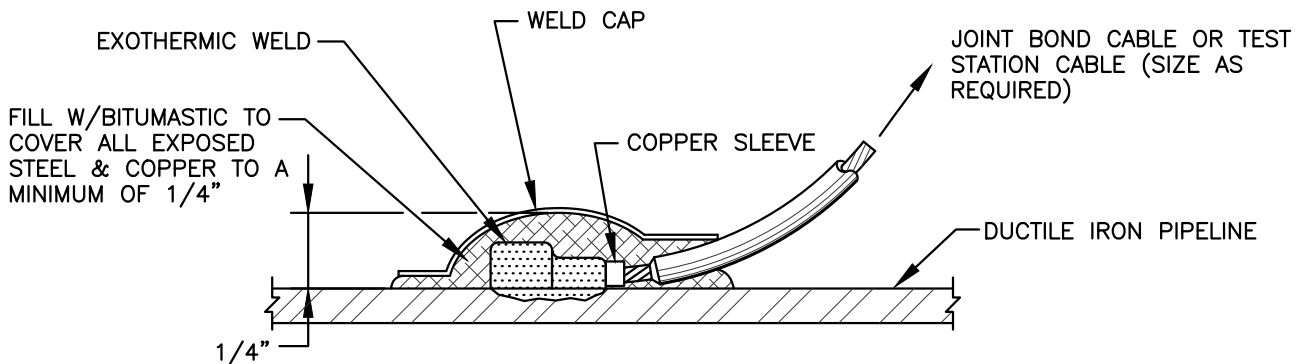

DIABLO WATER DISTRICT

STANDARD DRAWING  
EXOTHERMIC WELD

DESIGNED MA

DRAWN SC

APPROVED JDH

DATE OCTOBER 2022

DWG. NO.

DWD C6

**STEP 1.**

FILE STRUCTURE CONNECTION AREA TO BARE SHINY METAL AND CLEAN.

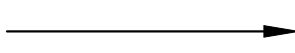

**STEP 2.**

STRIP INSULATION FROM WIRE. ATTACH LUG TO CABLE BY CRIMPING.

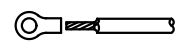
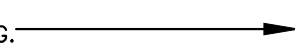

**STEP 3.**

LOAD GUN WITH THE BRAZING PIN AND FERRULE.

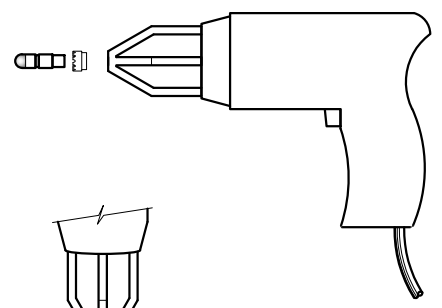
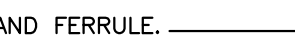

**STEP 4.**

ADJUST AS NECESSARY. BRAZE THE CABLE & LUG TO THE PIPE.

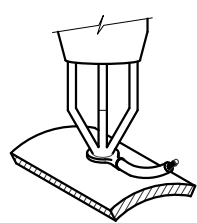
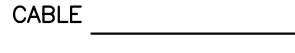

**STEP 5.**

PEEN CONNECTION WITH A HAMMER TO TEST CONNECTION FOR SOUNDNESS.

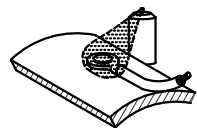
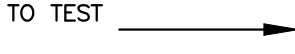

**STEP 6.**

COVER CONNECTION AND EXPOSED STRUCTURE SURFACE WITH EPOXY COATING COMPOUND WITH PLASTIC CAP & BITUMASTIC

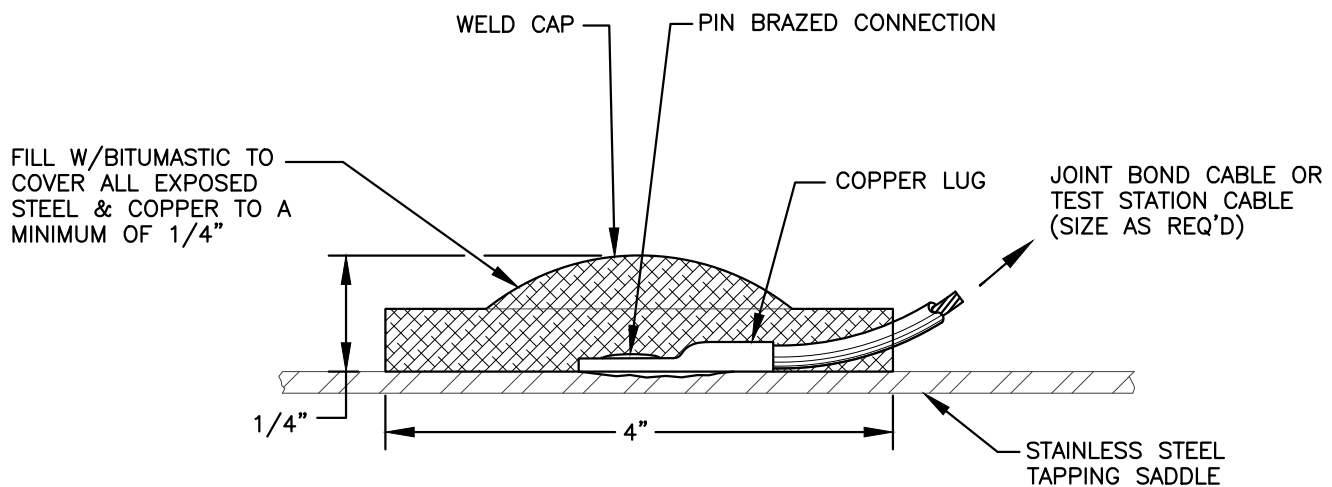
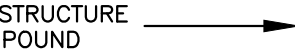

DIABLO WATER DISTRICT

STANDARD DRAWING  
PIN BRAZED CONNECTION

DESIGNED MA

DRAWN SC

APPROVED JDH

DATE OCTOBER 2022

DWG. NO. DWD C7

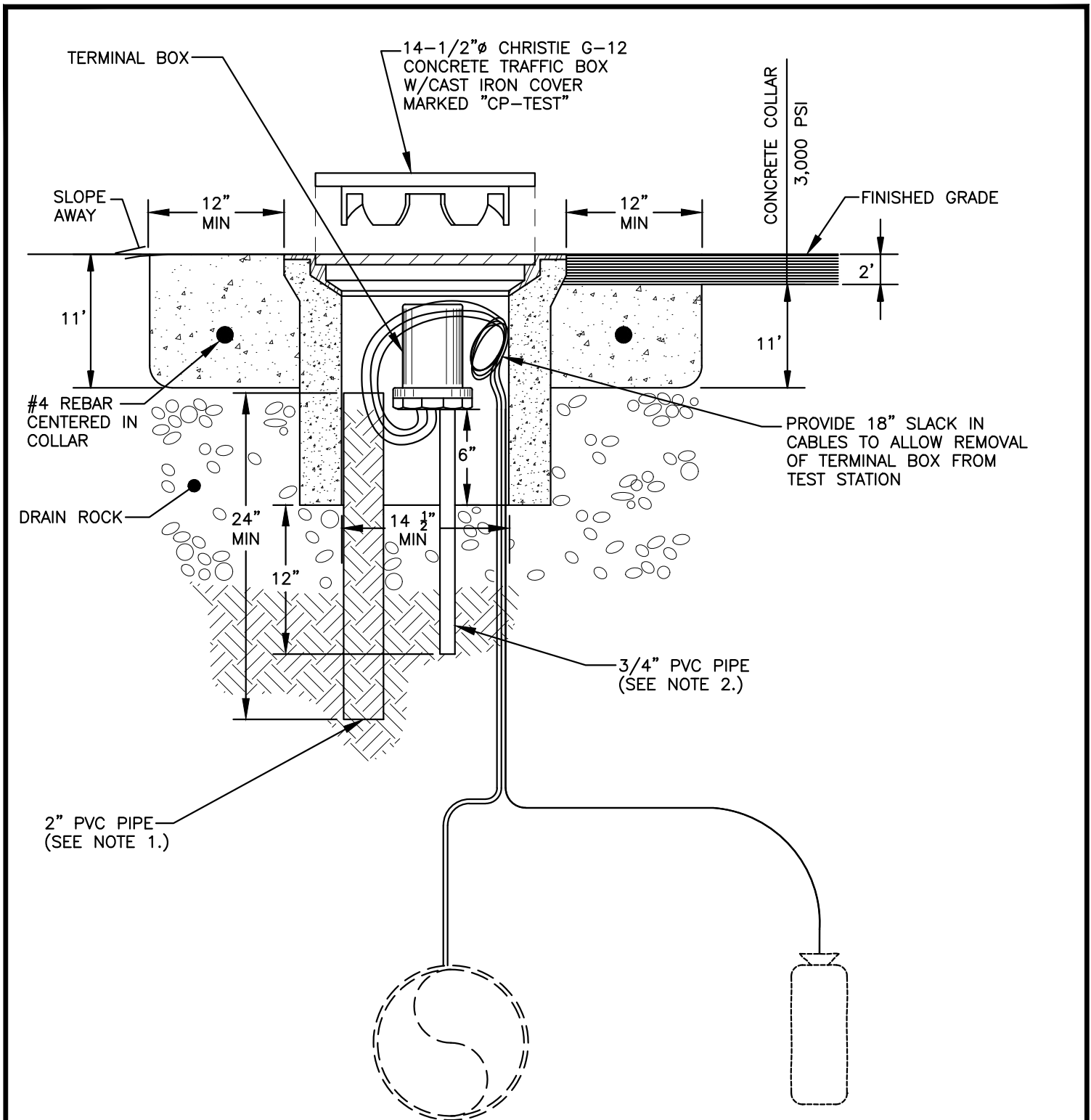

- NOTES:
1. INSTALL 2" PVC PIPE IN CLEAN NATIVE SOIL. FILL PIPE WITH CLEAN SOIL, FREE FROM ROCKS & DEBRIS.
  2. INSTALL 18" LENGTH OF 3/ 4" PVC PIPE TO ENSURE THAT THE TERMINAL BOX WILL REMAIN IN THE UPRIGHT POSITION. POSITION THE PIPE SO THAT THE TERMINAL BOX WILL BE AS HIGH AS POSSIBLE WITH THE CAST IRON LID STILL CLOSING PROPERLY.

<b>DIABLO WATER DISTRICT</b>		STANDARD DRAWING <b>FLUSH GRADE TEST STATION</b>		
DESIGNED <u>MA</u>	DRAWN <u>SC</u>	APPROVED <u>JDH</u>	DATE <u>OCTOBER 2022</u>	DWG. NO. <b>DWD C8</b>

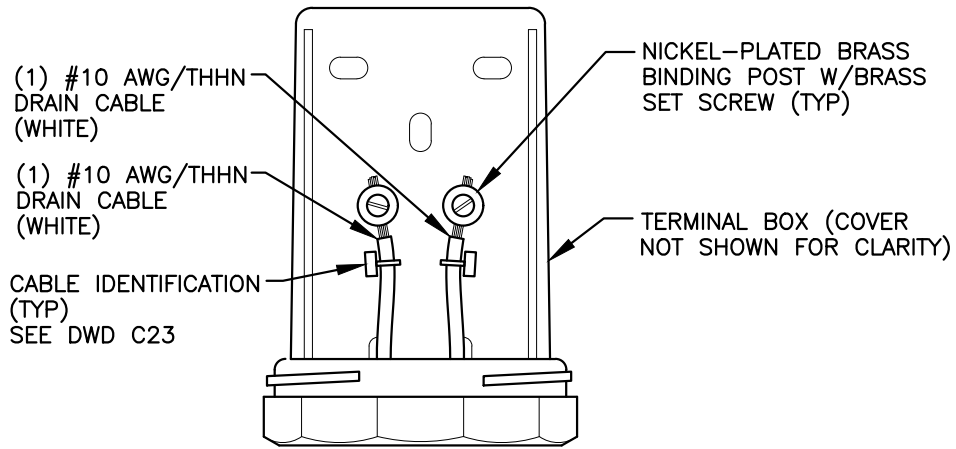

### CTS TERMINAL BOX

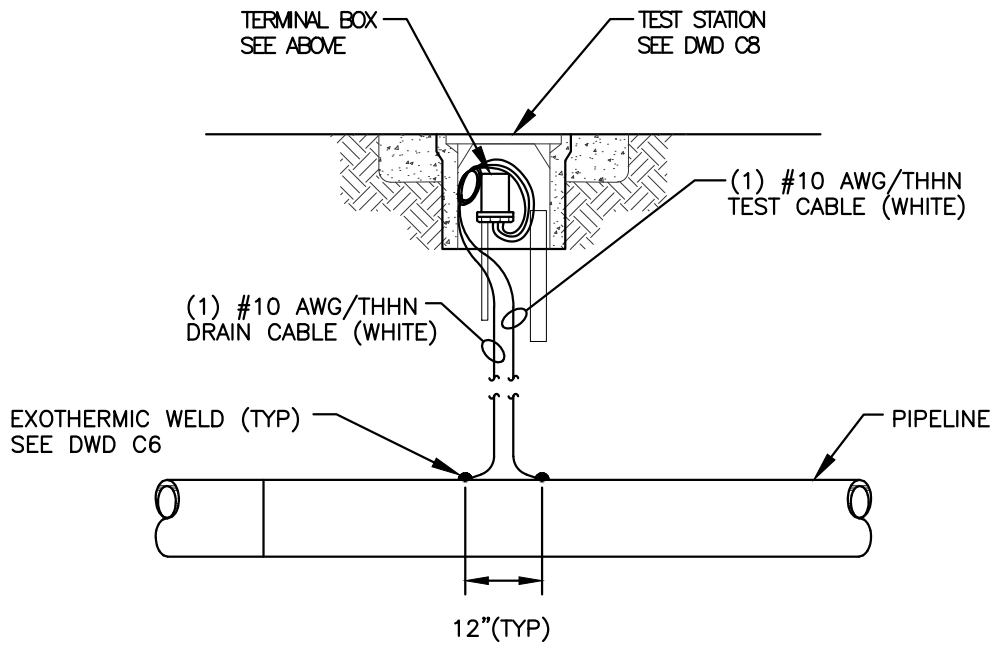

DIABLO WATER DISTRICT

STANDARD DRAWING  
CTS - CORROSION TEST STATION

DESIGNED MA

DRAWN SC

APPROVED JDH

DATE OCTOBER 2022

DWG. NO.

DWD C9

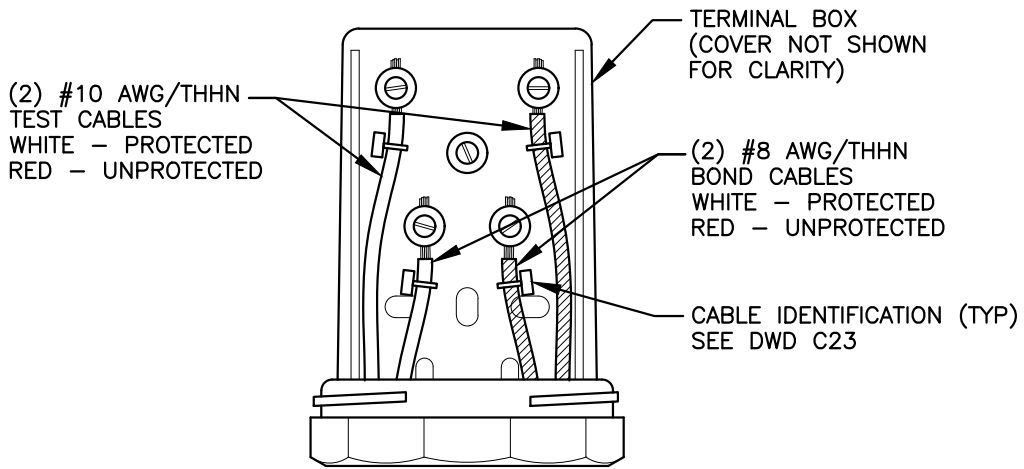

### IJTS TERMINAL BOX

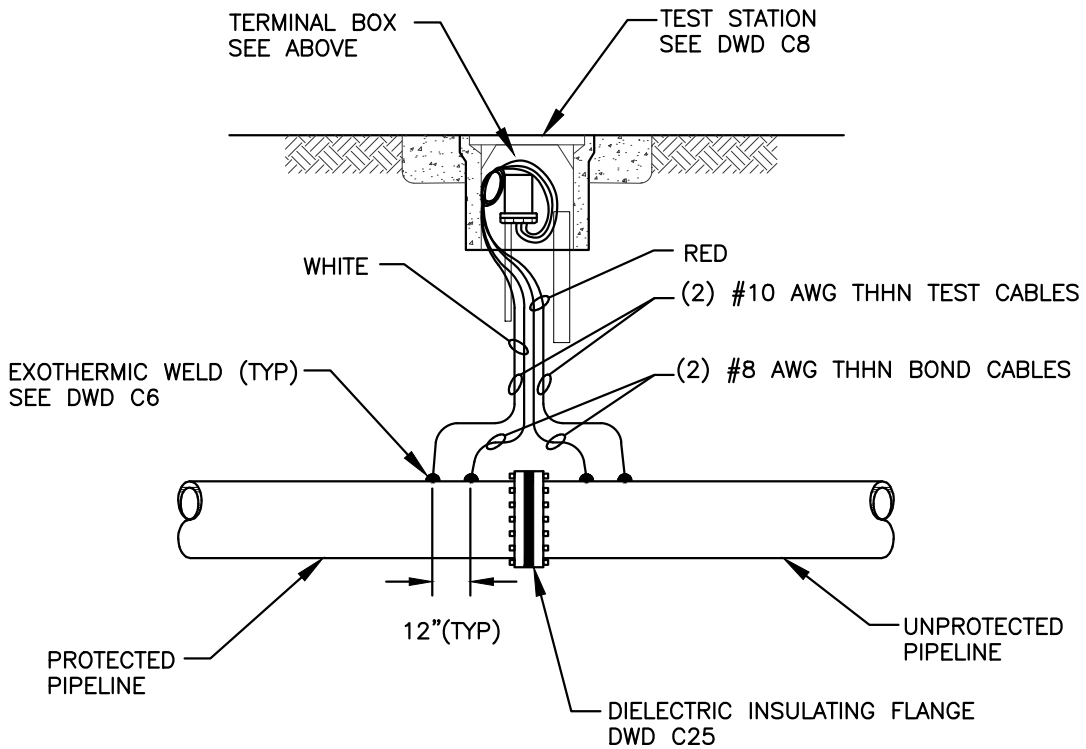

DIABLO WATER DISTRICT

STANDARD DRAWING  
IJTS - INSULATING JOINT TEST STATION

DESIGNED MA

DRAWN SC

APPROVED JDH

DATE OCTOBER 2022

DWG. NO.

DWD C10



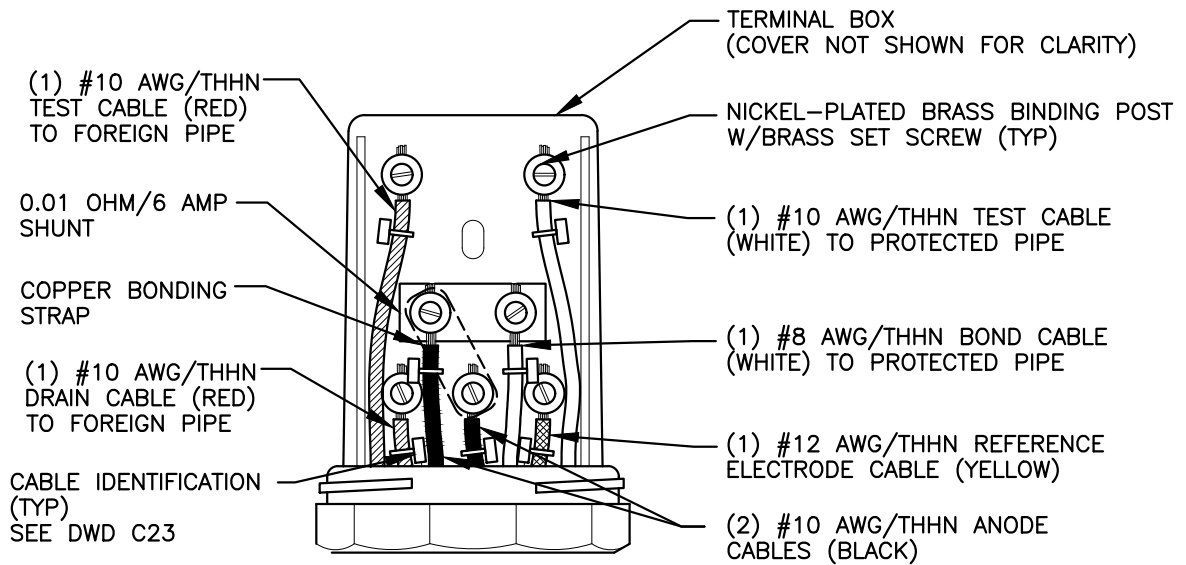

### FPTS TERMINAL BOX

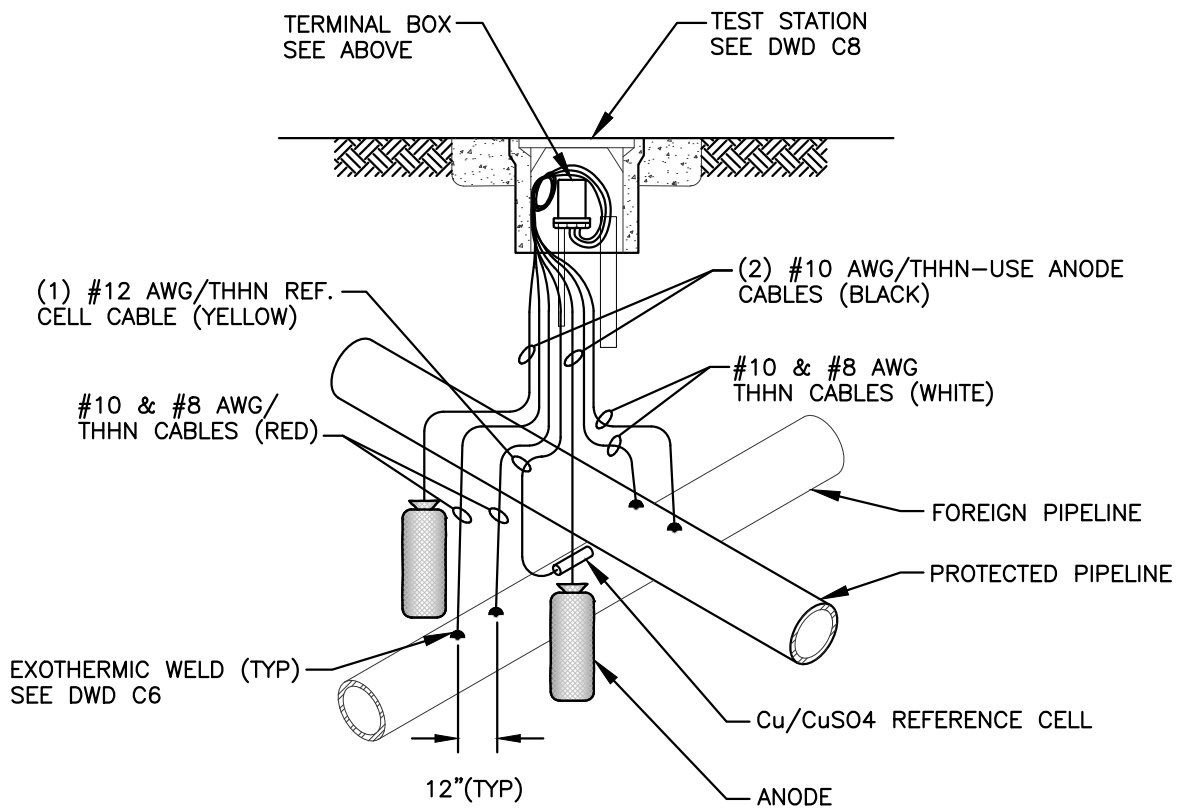

**NOTES:**

1. INSTALL THE REFERENCE CELL BETWEEN THE TWO PIPELINES.
2. PERMISSION MUST BE OBTAINED FROM THE FOREIGN PIPELINE OWNER PRIOR TO ATTACHMENT OF TEST WIRES TO FOREIGN PIPE.

DIABLO WATER DISTRICT

STANDARD DRAWING  
FPTS - FOREIGN PIPELINE TEST STATION

DESIGNED MA

DRAWN SC

APPROVED JDH

DATE OCTOBER 2022

DWG. NO.

**DWD C11**

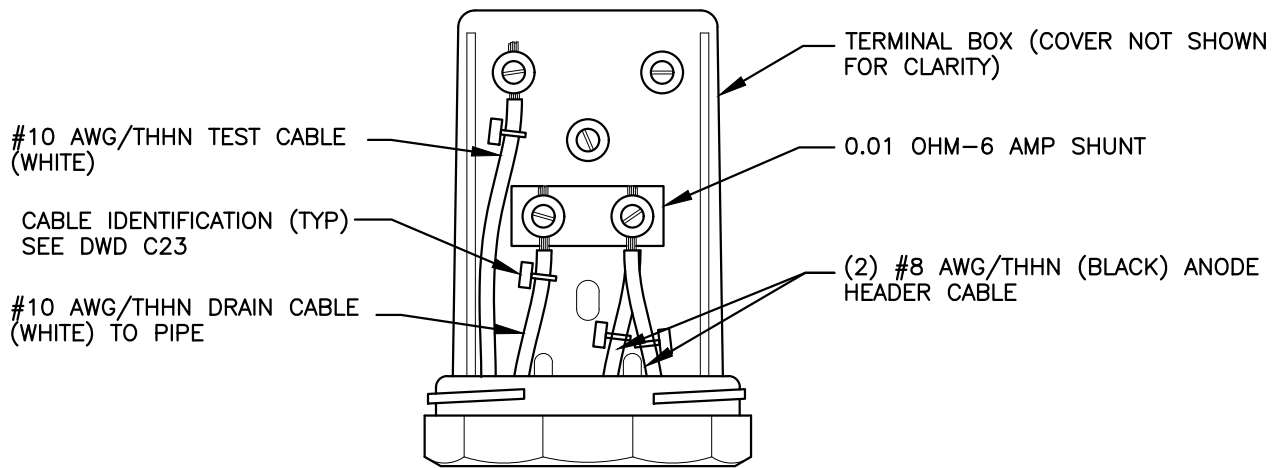

### ATS TERMINAL BOX

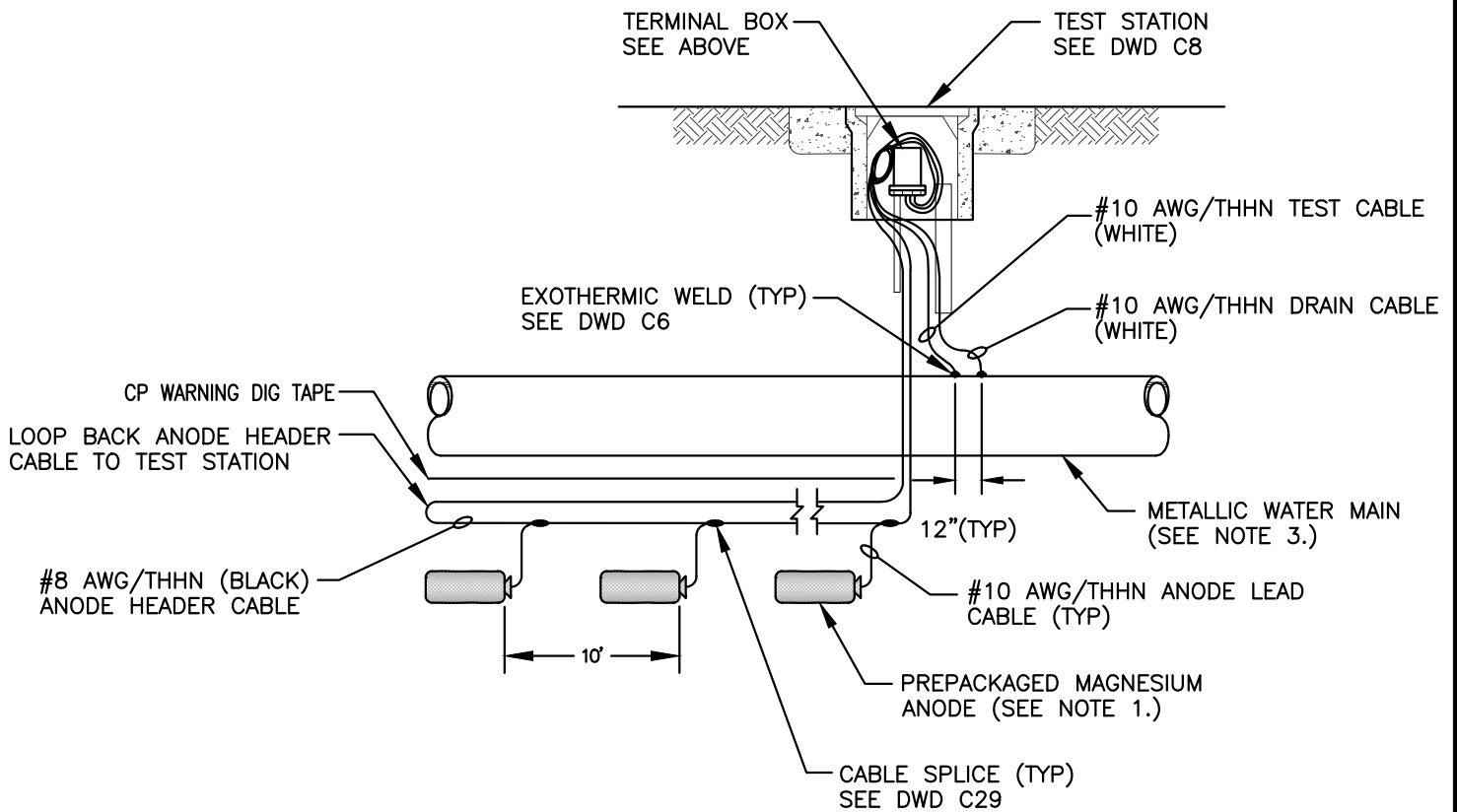

**NOTES:**

1. NUMBER AND SIZE OF ANODES SHALL BE DETERMINED BY THE PROJECT CORROSION ENGINEER.
2. THE ANODES SHALL BE INSTALLED A MINIMUM OF 3 FT. OFF THE WALL OF THE WATER PIPE.
3. BOND ALL PIPE JOINTS PER DRAWING DWD C4.

DIABLO WATER DISTRICT

STANDARD DRAWING  
ATS - ANODE TEST STATION

DESIGNED MA

DRAWN SC

APPROVED JDH

DATE OCTOBER 2022

DWG. NO.

DWD C12

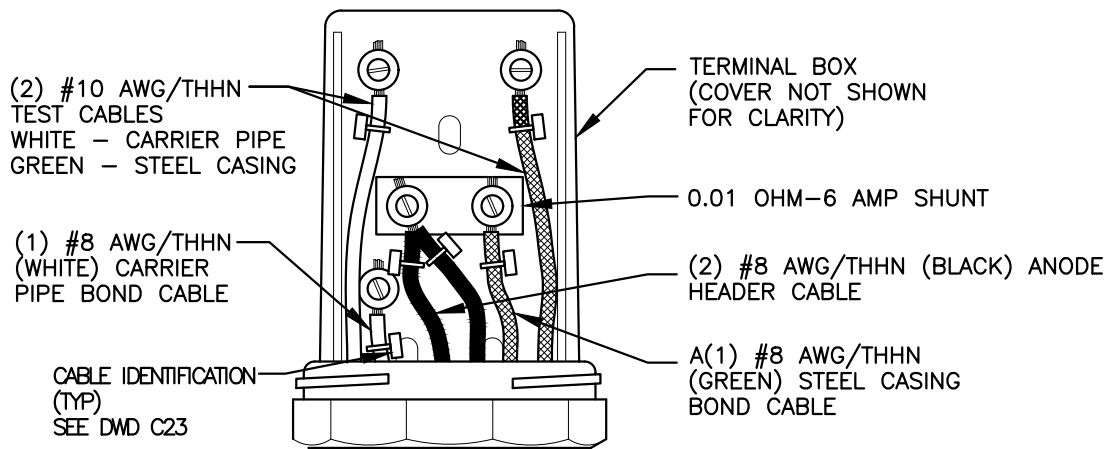

### CATS TERMINAL BOX

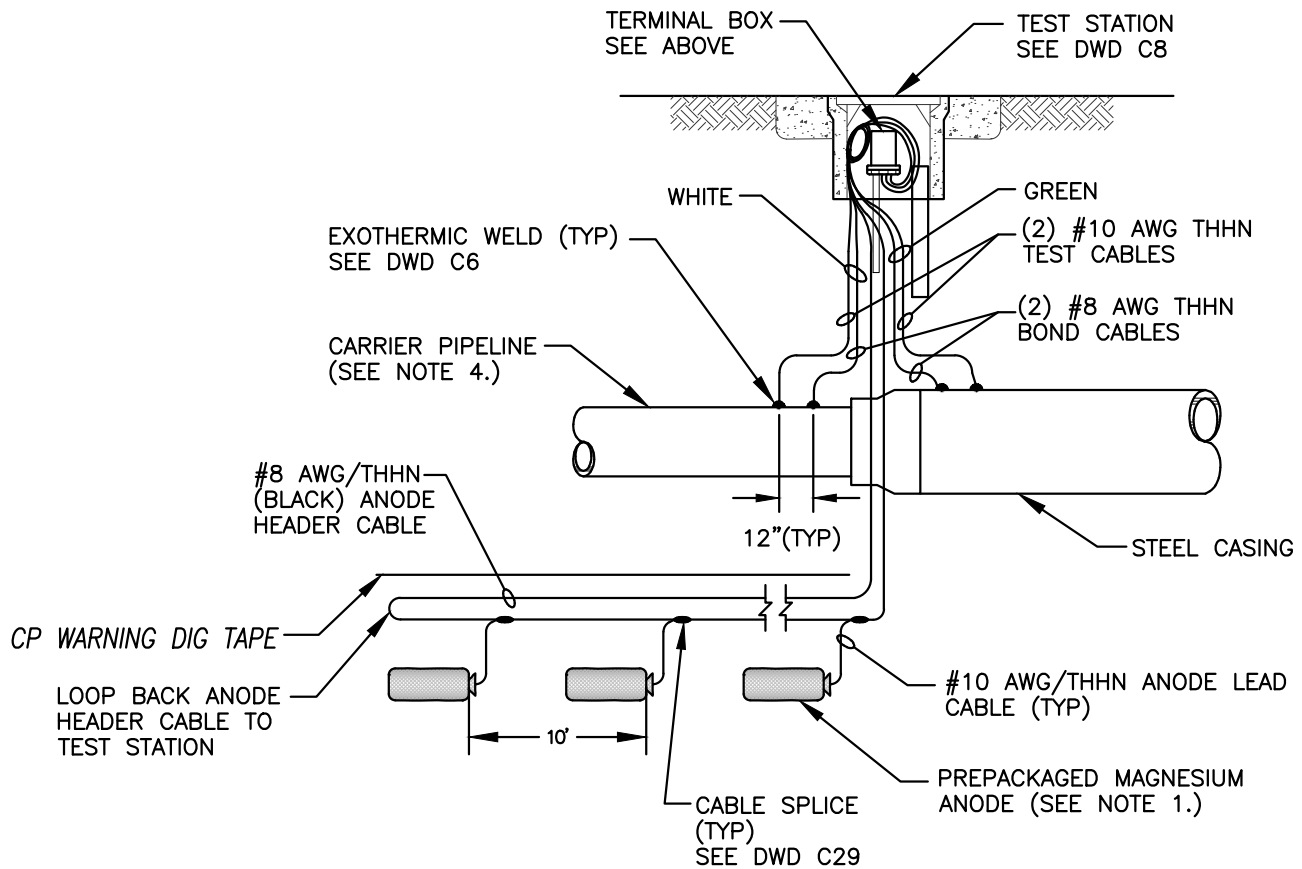

**NOTES:**

1. NUMBER AND SIZE OF ANODES SHALL BE DETERMINED BY THE PROJECT CORROSION ENGINEER.
2. CARRIER PIPE & CASING ARE TO BE ELECTRICALLY ISOLATED VIA CASING INSULATORS.
3. IF CARRIER PIPE IS NON-METALLIC DELETE WHITE CABLES AND EXOTHERMIC WELDS.
4. BOND ALL PIPE JOINTS PER DRAWING DWD C4.

DIABLO WATER DISTRICT

STANDARD DRAWING  
CATS - CASING ANODE TEST STATION

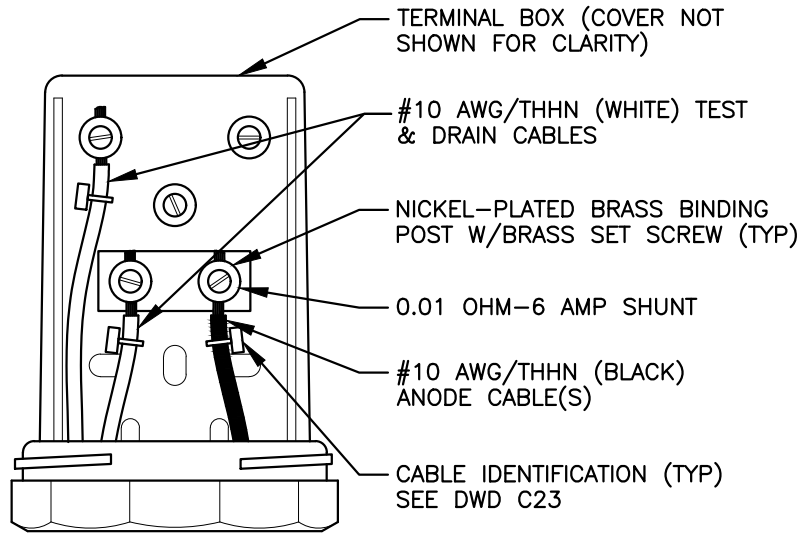

### VATS TERMINAL BOX

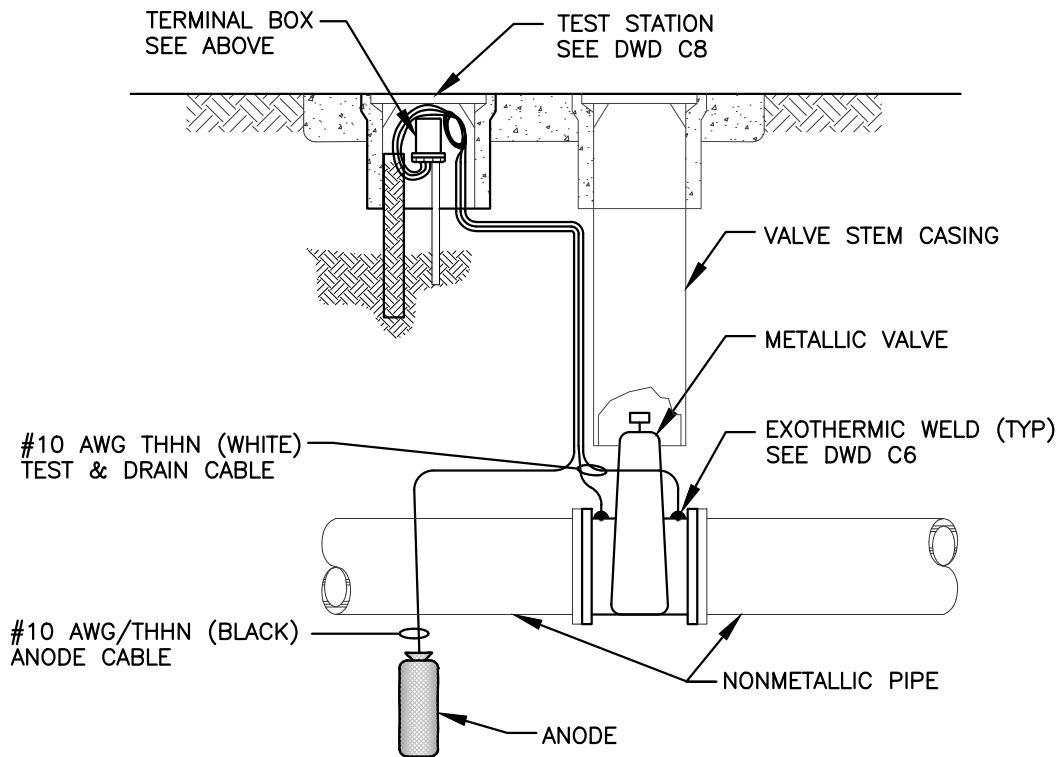

**NOTE:**

1. INSTALL ANODE A MINIMUM OF 3- FEET FROM VALVE.

DIABLO WATER DISTRICT

STANDARD DRAWING  
VATS - VALVE ANODE TEST STATION

DESIGNED MA

DRAWN SC

APPROVED JDH

DATE OCTOBER 2022

DWG. NO.

**DWD C14**

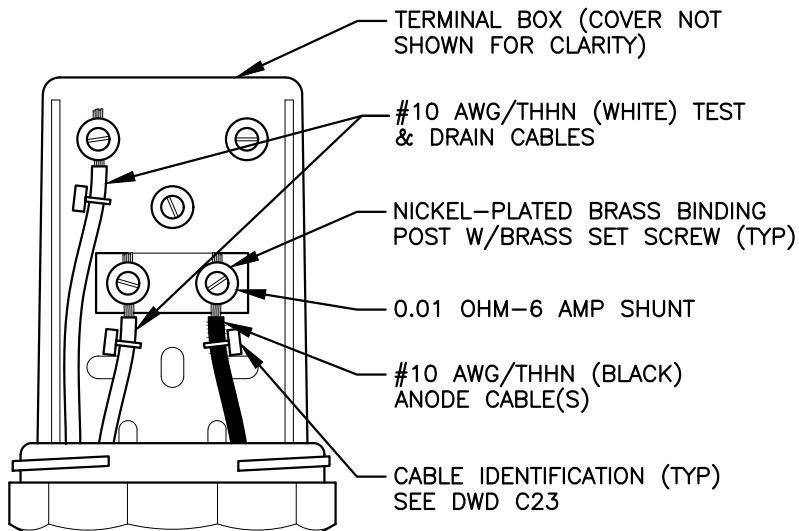

**VATS TERMINAL BOX**

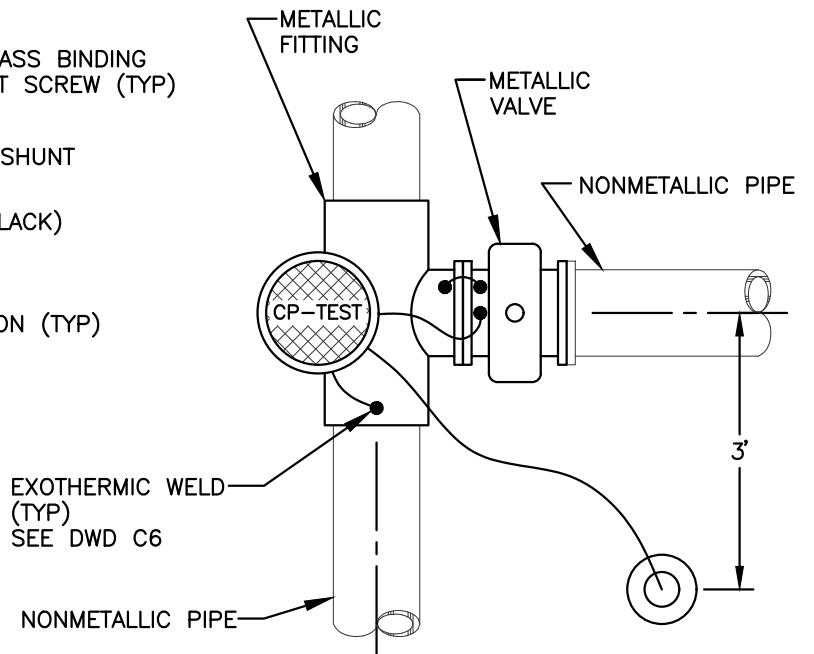

**PLAN**

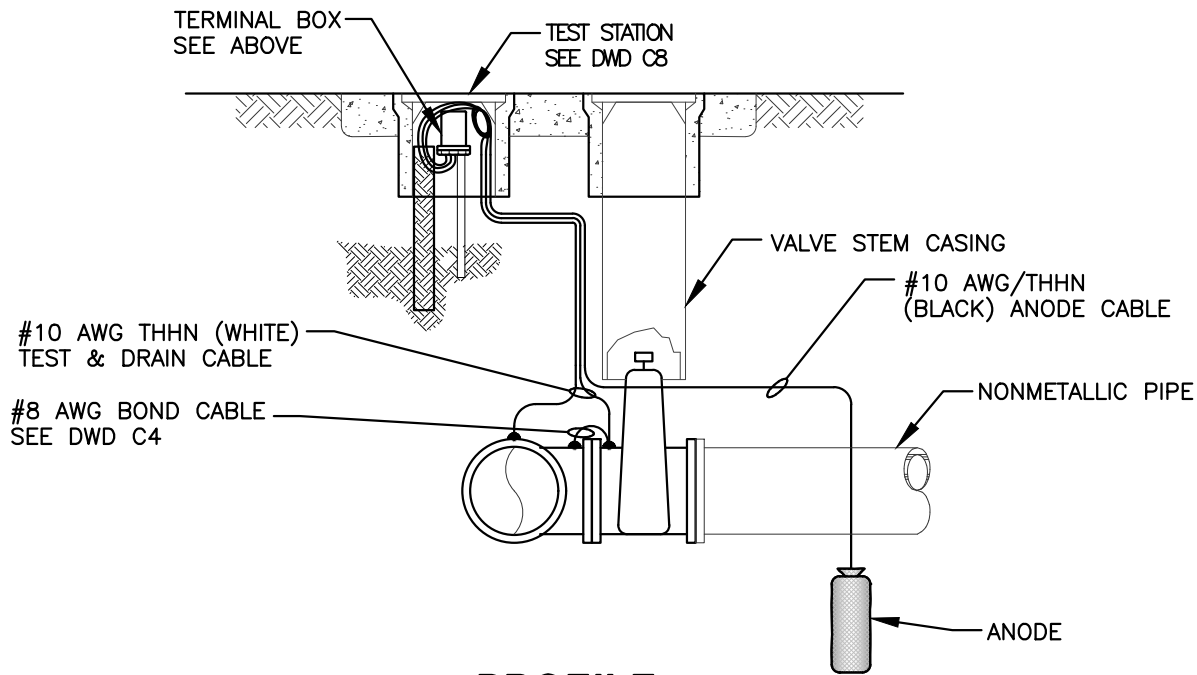

**PROFILE**

NOTE:  
1. INSTALL ANODE A MINIMUM OF 3-FEET FROM THE VALVE & TEE.

DIABLO WATER DISTRICT

STANDARD DRAWING  
VATS - VALVE AND TEE ANODE TEST STATION

DESIGNED MA

DRAWN SC

APPROVED JDH

DATE OCTOBER 2022

DWG. NO. DWD C15

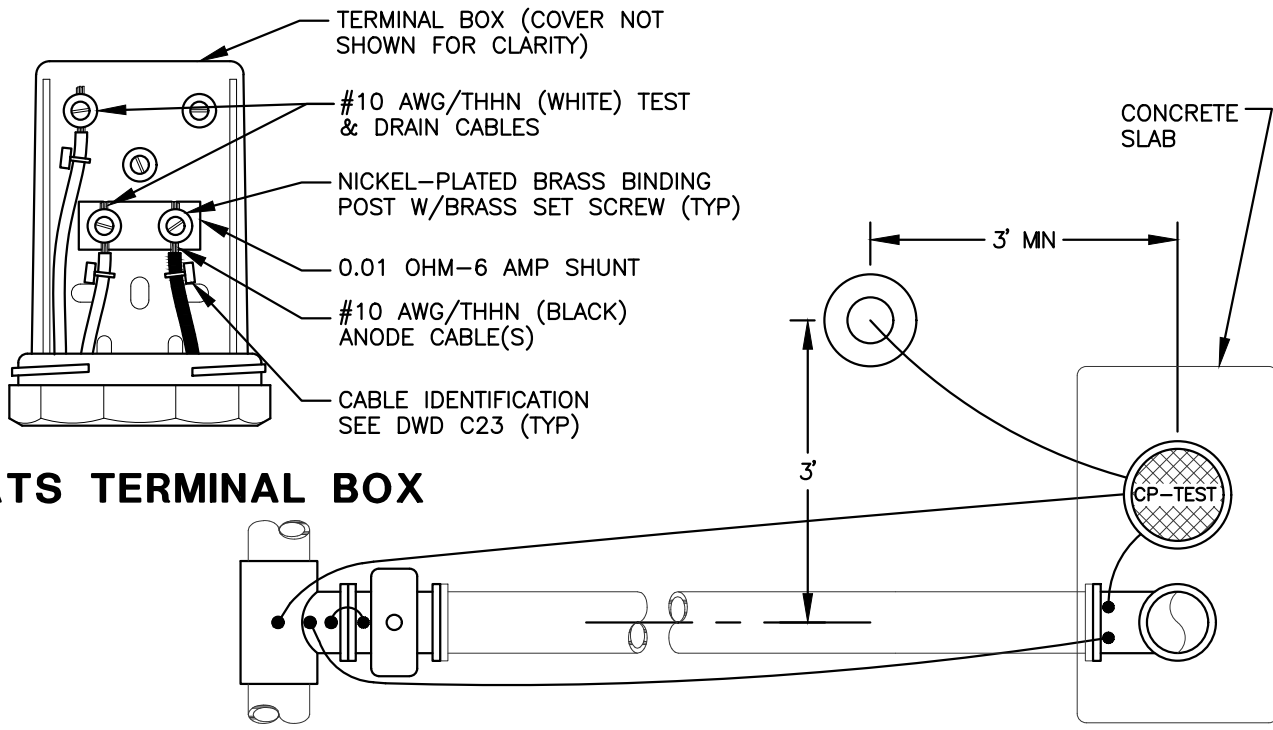

**ATS TERMINAL BOX**

**PLAN**

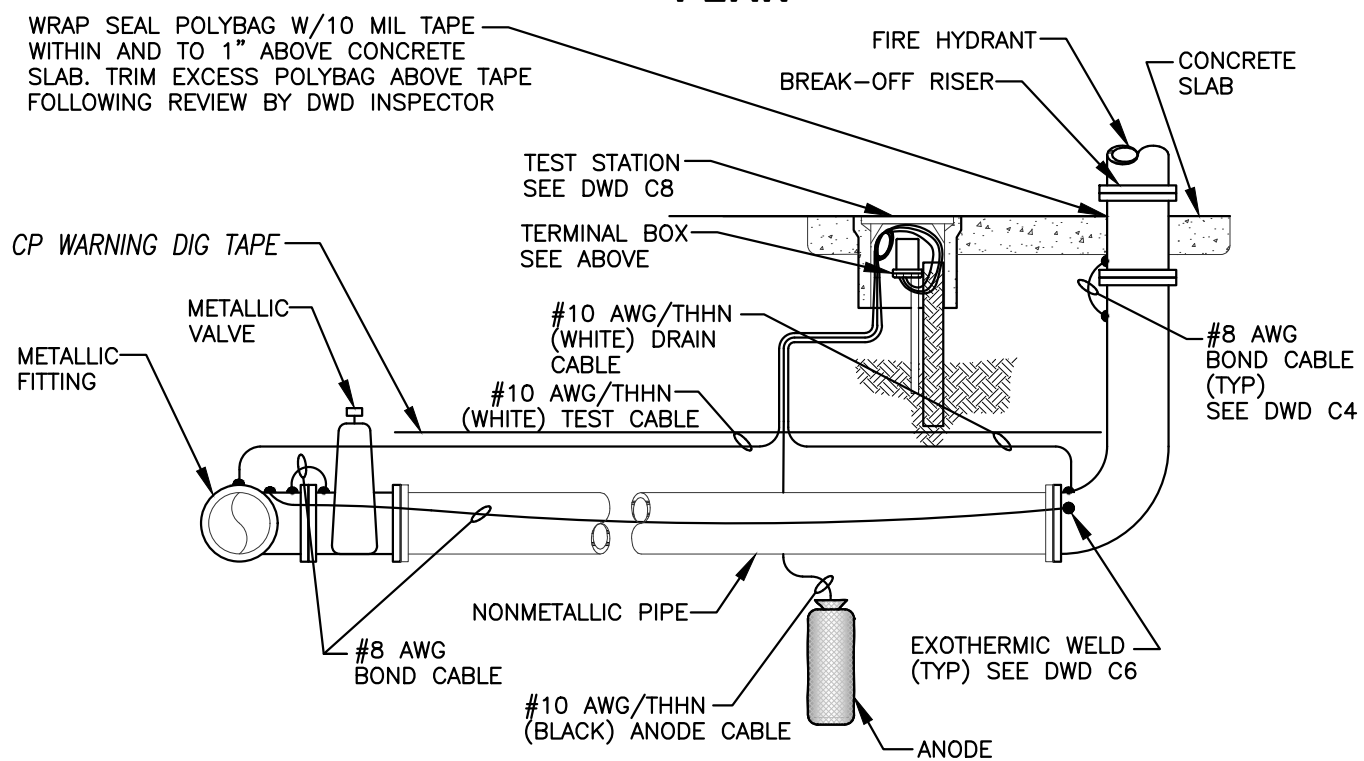

**PROFILE**

- NOTE:
1. INSTALL TEST STATION IN COMMON CONCRETE SLAB WITH F.H. RISER.
  2. INSTALL ANODE A MINIMUM OF 3 FEET AWAY FROM THE PIPE.

DIABLO WATER DISTRICT		STANDARD DRAWING			
		<b>FHATS - FIRE HYDRANT ANODE TEST STATION</b>			
DESIGNED MA	DRAWN SC	APPROVED JDH	DATE OCTOBER 2022	DWG. NO. DWD C16	

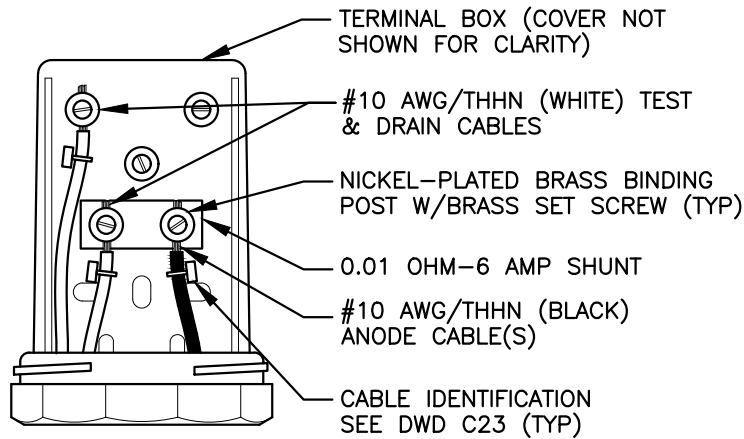

**ATS TERMINAL BOX**

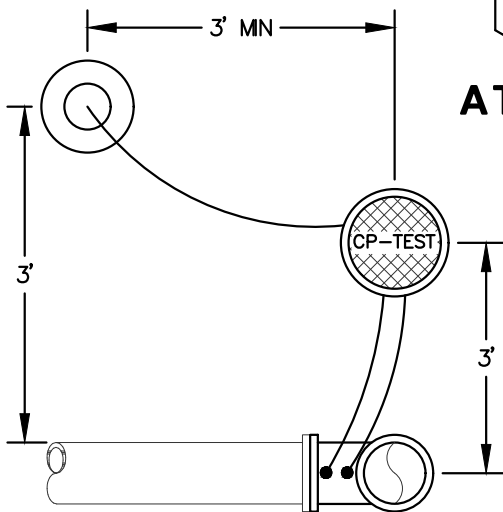

**PLAN**

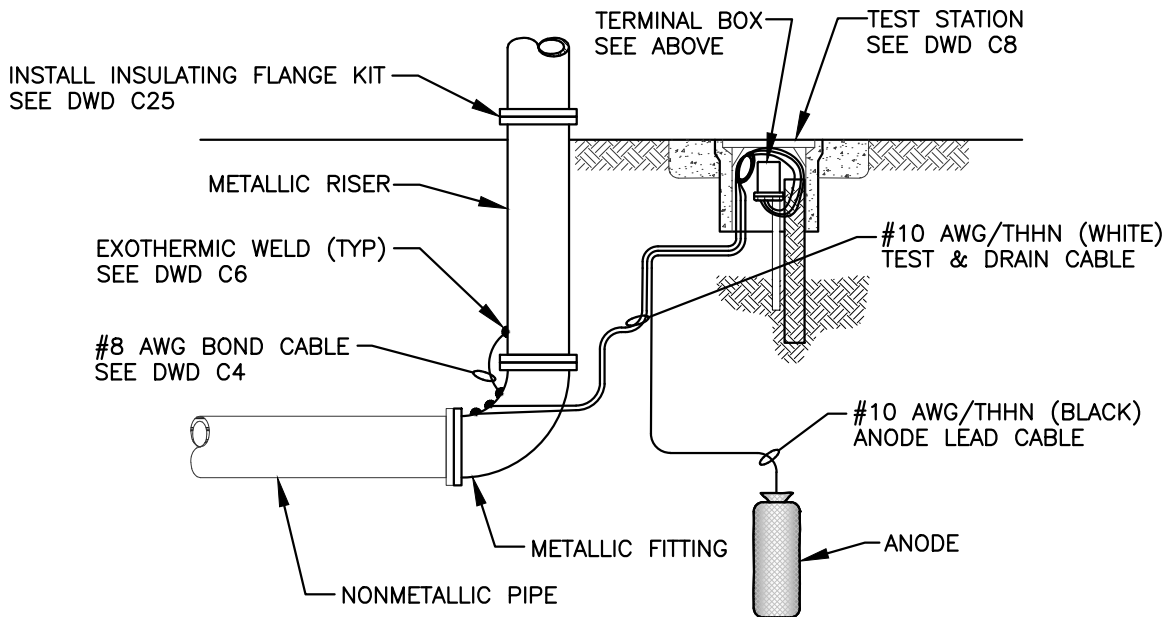

**PROFILE**

NOTE:  
1. INSTALL ANODE A MINIMUM OF 3 FEET AWAY FROM THE PIPE.

DIABLO WATER DISTRICT

STANDARD DRAWING  
METALLIC RISER ANODE TEST STATION

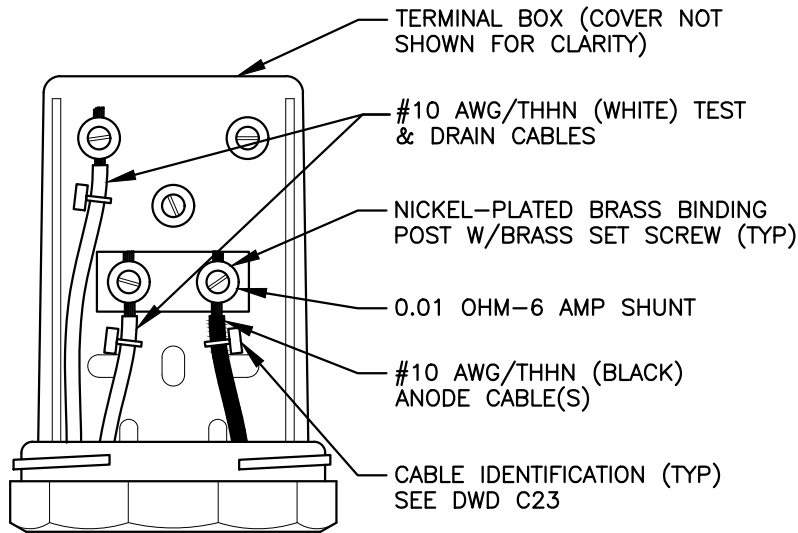

## ATS TERMINAL BOX

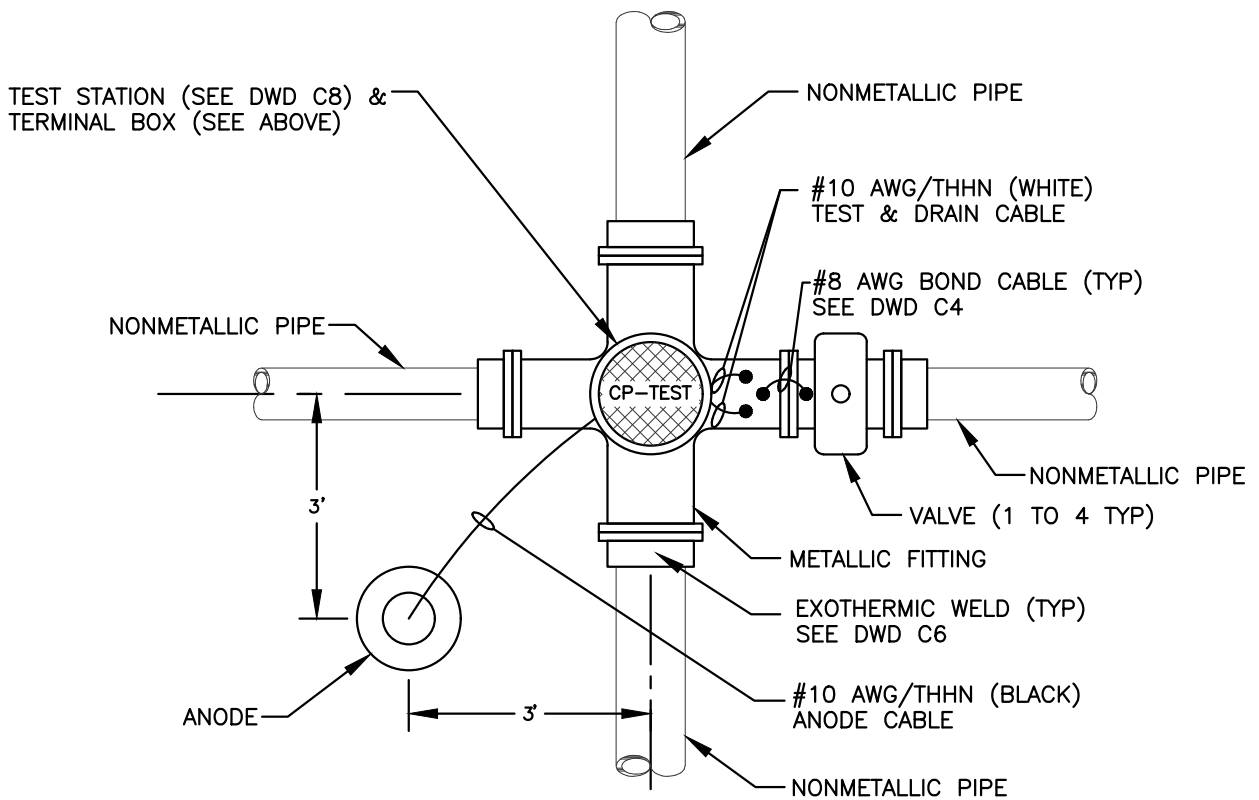

## PLAN

- NOTE:  
1. INSTALL ANODE A MINIMUM OF 3 FEET AWAY FROM THE VALVE/FITTING.

DIABLO WATER DISTRICT

STANDARD DRAWING  
CROSS AND VALVES ANODE TEST STATION

DESIGNED

MA

DRAWN

SC

APPROVED

JDH

DATE

OCTOBER 2022

DWG. NO.

DWD C18



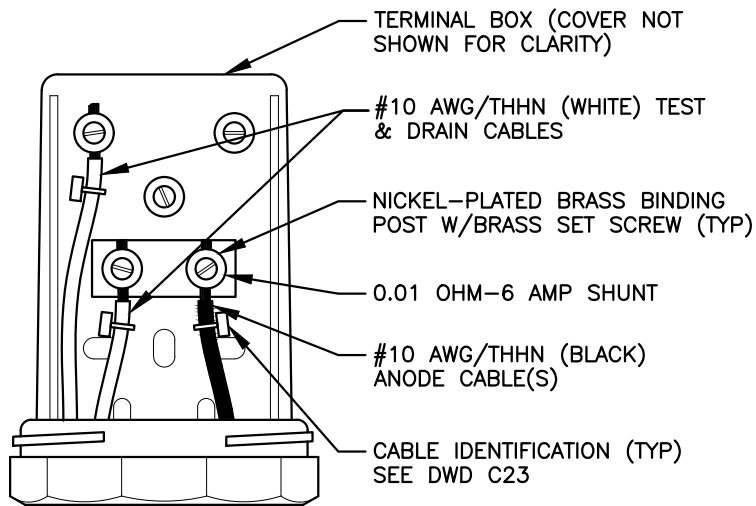

### ATS TERMINAL BOX

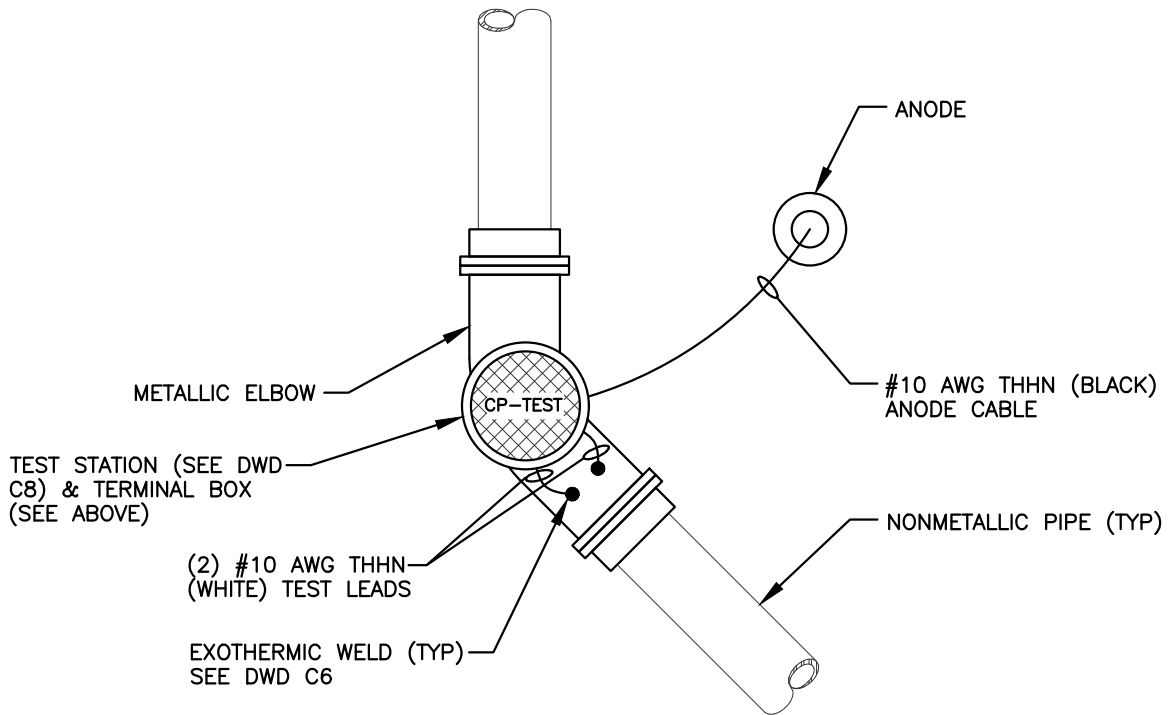

### PLAN

**NOTE:**

1. INSTALL ANODE A MINIMUM OF 3 FEET AWAY FROM THE ELBOW.

DIABLO WATER DISTRICT

STANDARD DRAWING  
ELBOW ANODE TEST STATION

DESIGNED MA

DRAWN SC

APPROVED JDH

DATE OCTOBER 2022

DWG. NO.

**DWD C19**

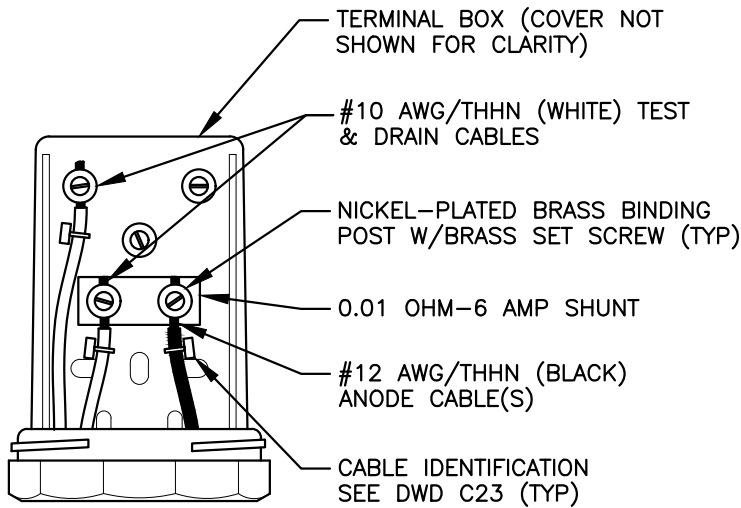

## ATS TERMINAL BOX

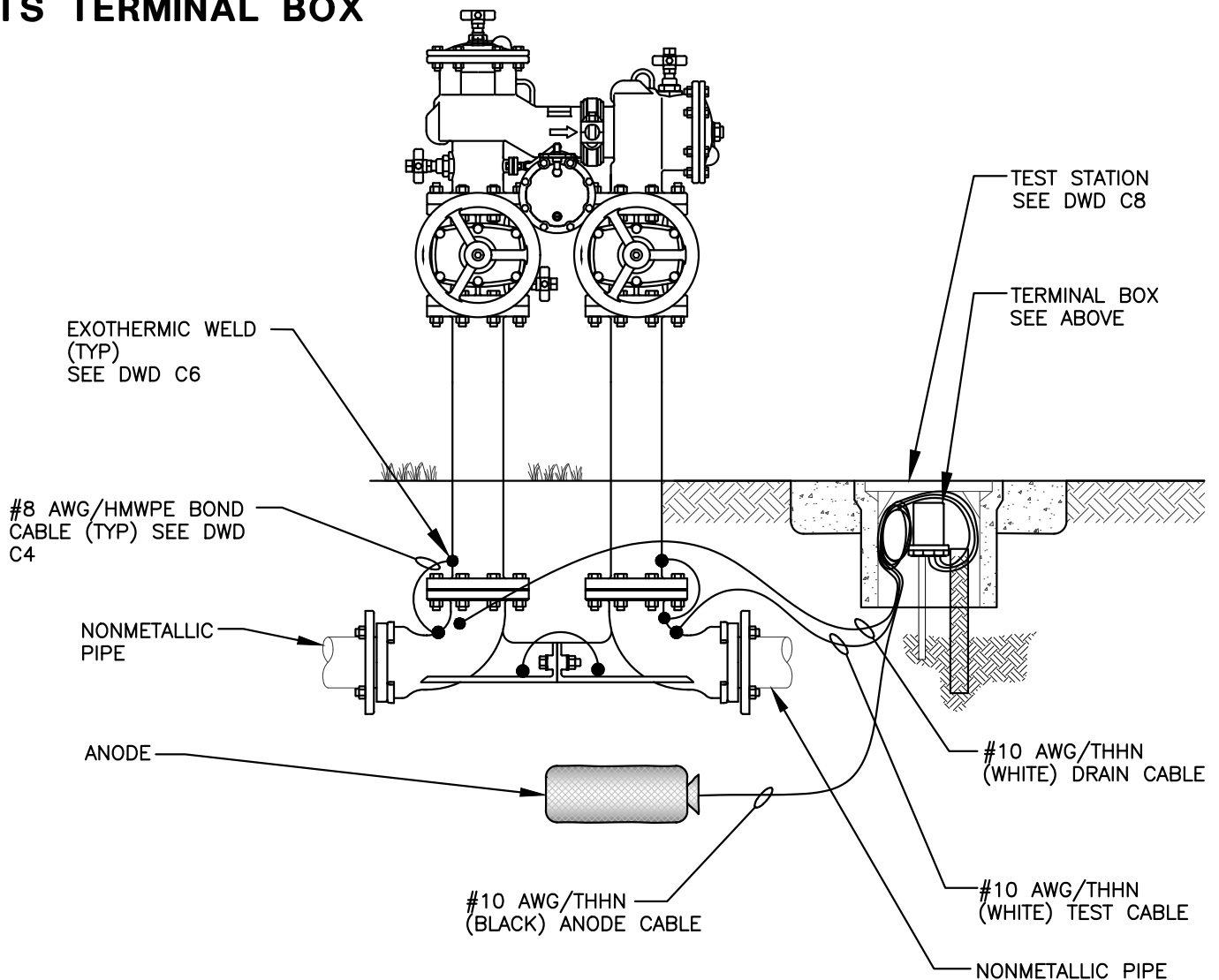

NOTE:  
1. INSTALL ANODE A MINIMUM OF 3- FEET FROM RISER.

DIABLO WATER DISTRICT

STANDARD DRAWING  
DOUBLE DETECTOR CHECK ASSEMBLY PREVENTER  
OR RBP ANODE TEST STATION

DESIGNED

MA

DRAWN

SC

APPROVED

JDH

DATE

OCTOBER 2022

DWG. NO.

DWD C20

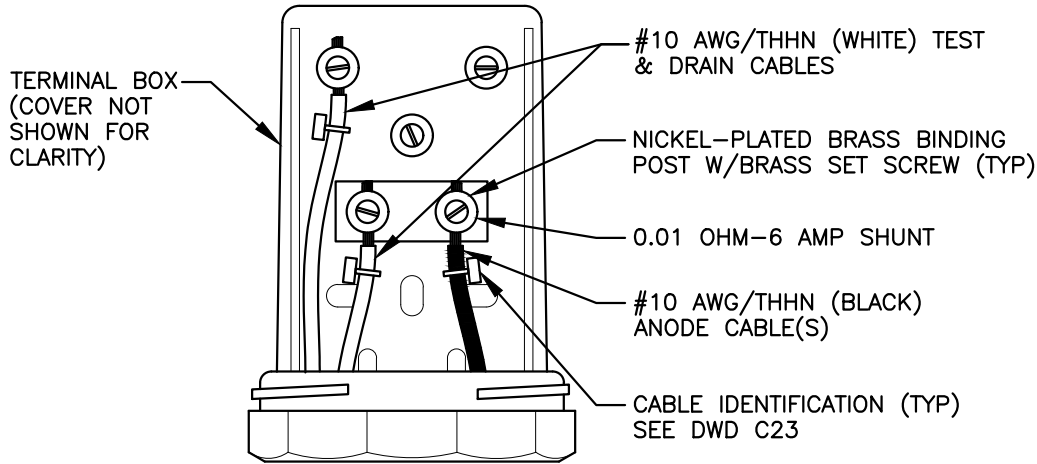

### ATS TERMINAL BOX

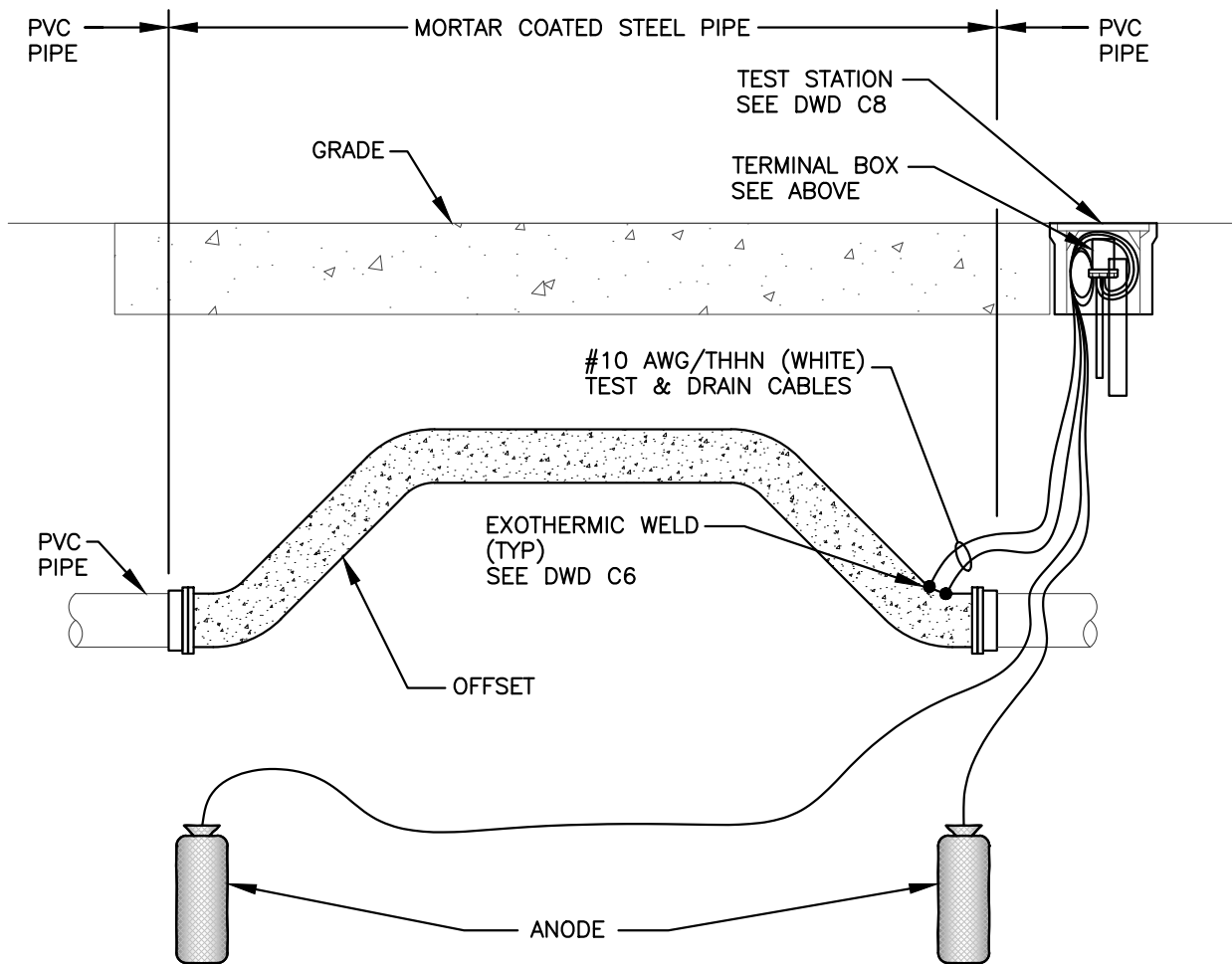

**NOTE:**

1. THE ANODE SHALL BE INSTALLED VERTICALLY OR HORIZONTALLY WITH THE TOP OF THE ANODE 5 FEET BELOW GRADE AND 3 FEET BELOW PIPE.

DIABLO WATER DISTRICT

STANDARD DRAWING  
DOUBLE OFFSET ANODE TEST STATION

DESIGNED MA

DRAWN SC

APPROVED JDH

DATE OCTOBER 2022

DWG. NO.

DWD C21

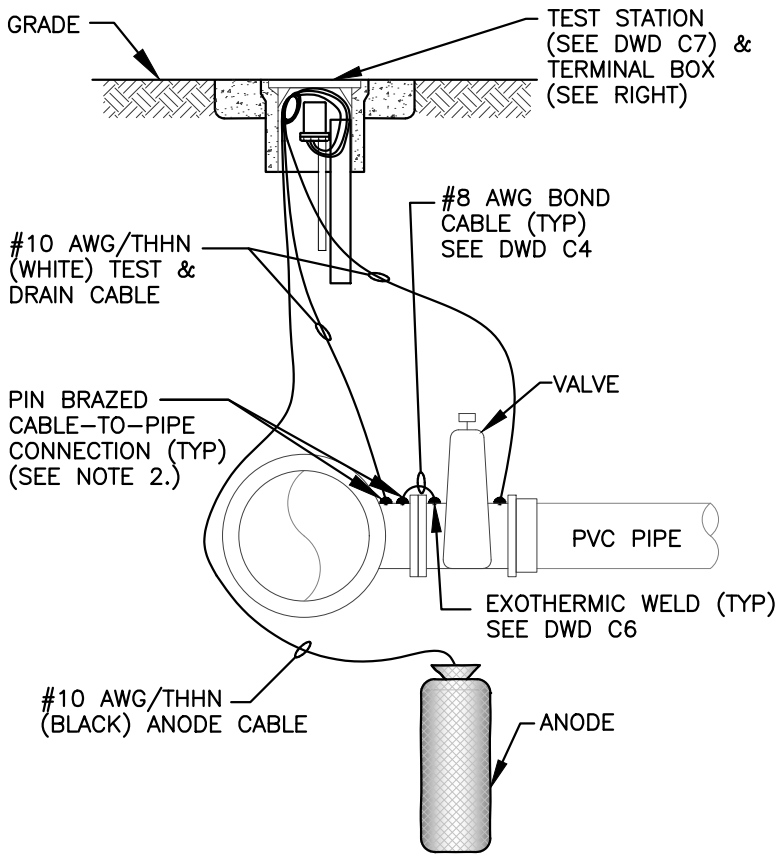

**PROFILE**

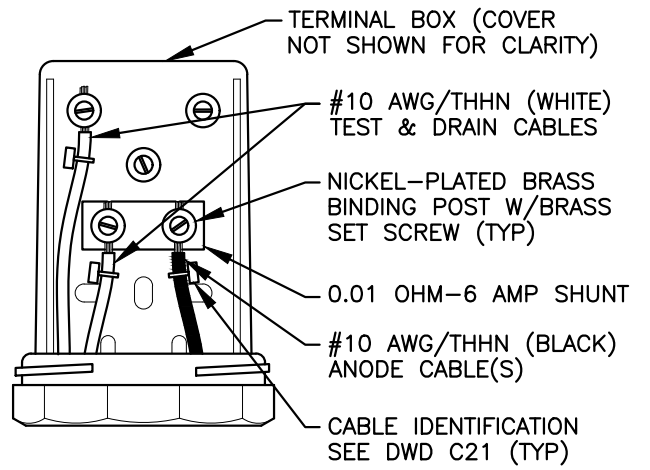

**ATS TERMINAL BOX**

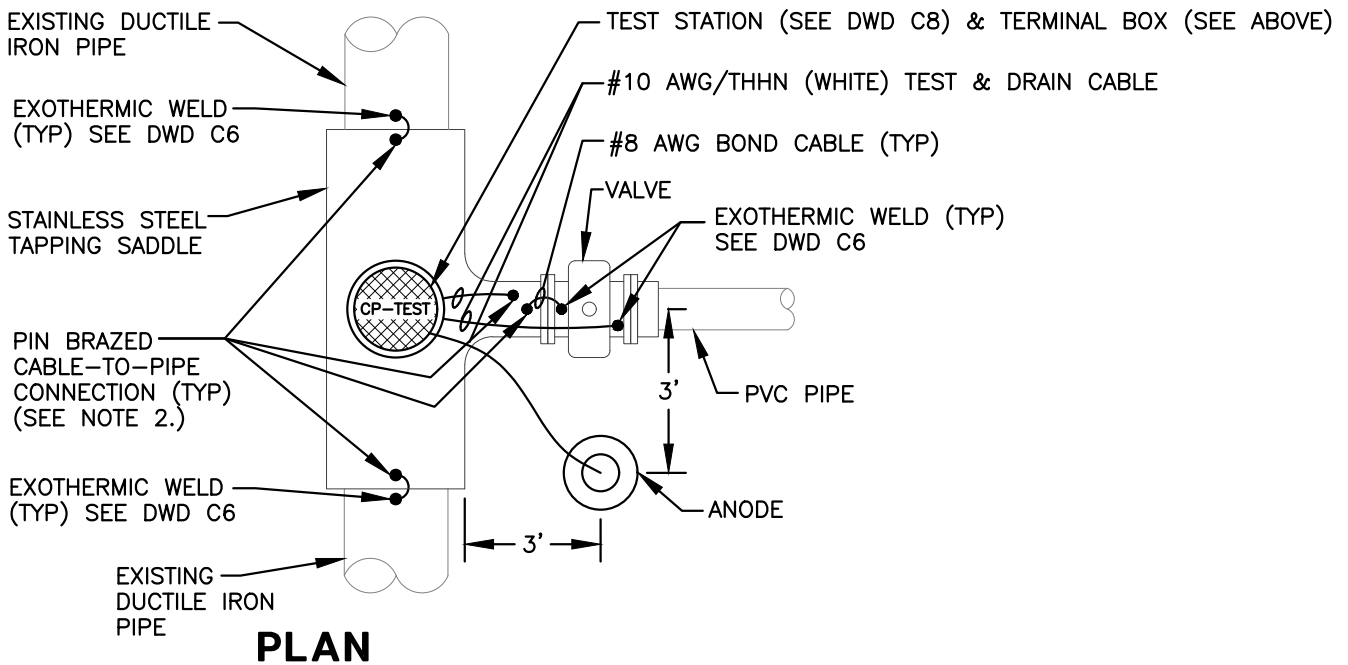

**PLAN**

NOTE:  
1. CABLE-TO-PIPE CONNECTIONS TO STAINLESS STEEL FITTINGS SHALL BE MADE BY PIN BRAZING.

DIABLO WATER DISTRICT

STANDARD DRAWING  
TAPPING SADDLE ANODE TEST STATION

DESIGNED

MA

DRAWN

SC

APPROVED

JDH

DATE

OCTOBER 2022

DWG. NO.

DWD C22

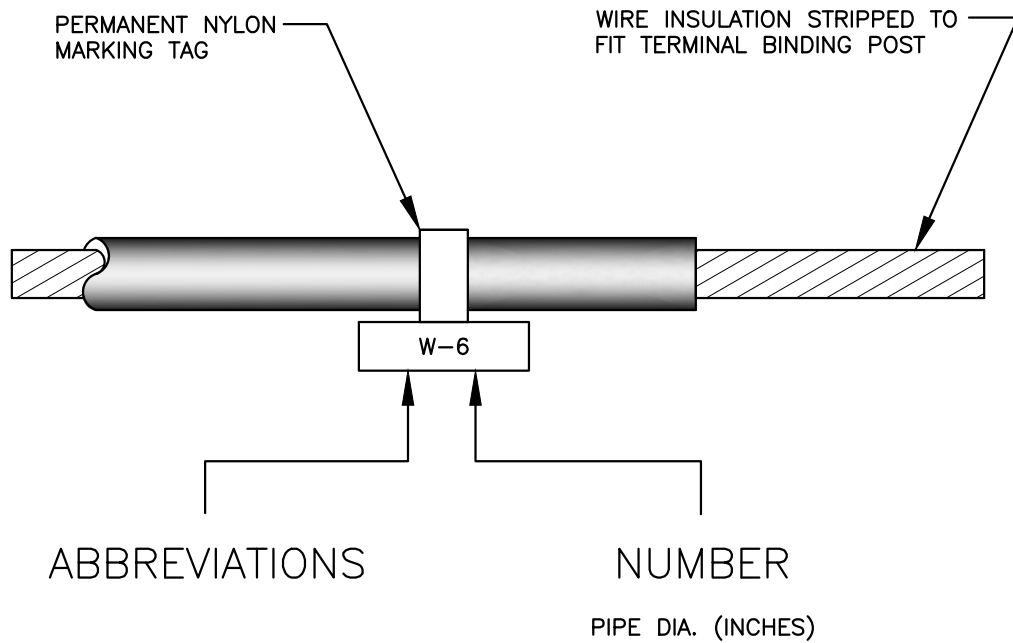

- AN - ANODE
- BO - BLOW OFF
- CA - CASING
- DR - DRAIN CABLE
- DW - DOMESTIC WATER
- EL - ELBOW
- FH - FIRE HYDRANT
- FP - FOREIGN PIPELINE
- RE - REFERENCE ELECTRODE
- RW - RAW WATER
- TT - TEST CABLE

DIABLO WATER DISTRICT

STANDARD DRAWING  
CABLE IDENTIFICATION

DESIGNED MA

DRAWN SC

APPROVED JDH

DATE OCTOBER 2022

DWG. NO. DWD C23

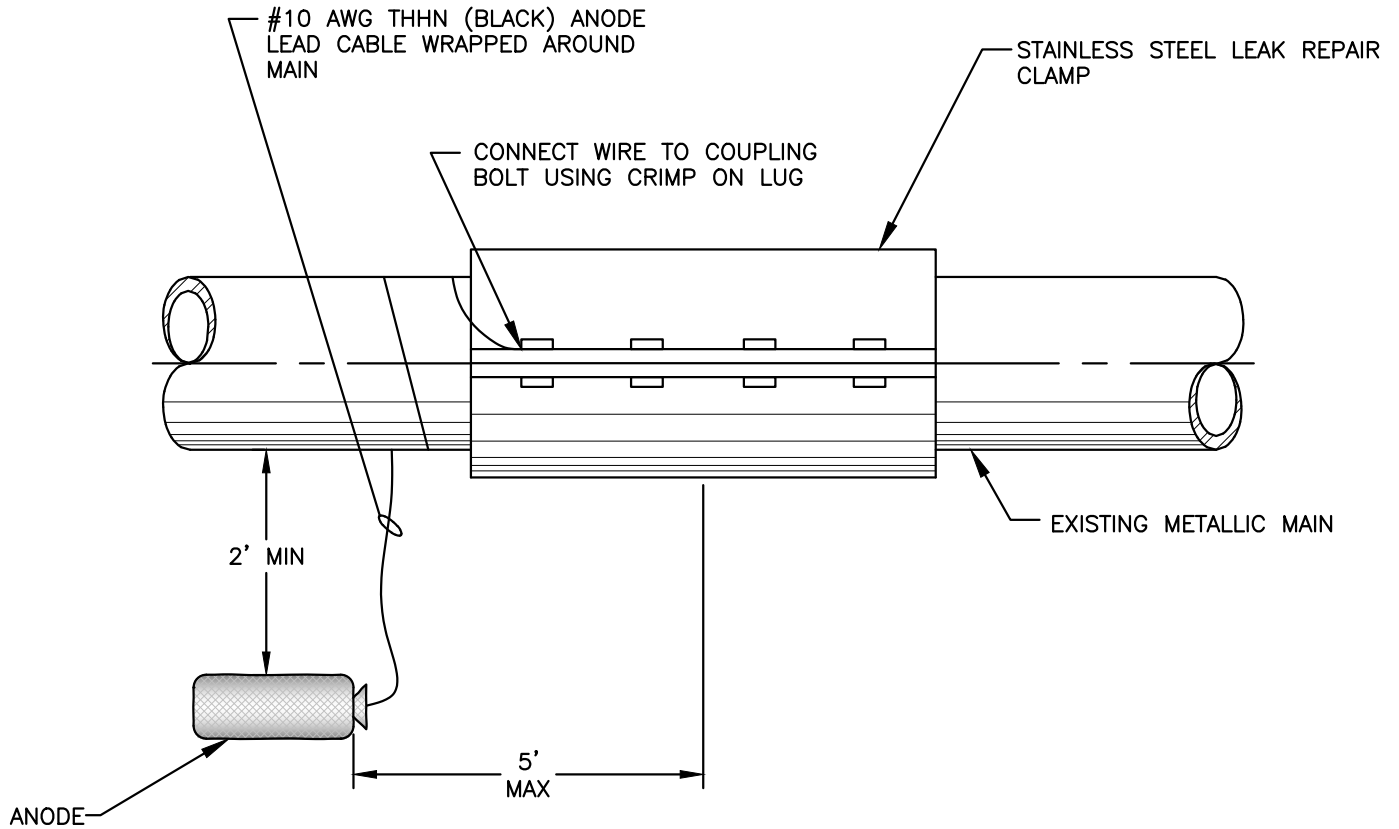

NOTES:

1. INSTALL ANODE A MINIMUM OF 2- FEET BELOW PIPE DEPTH IN NATIVE SOIL.
2. MAXIMUM HORIZONTAL DISTANCE FROM ANODE TO LEAK REPAIR CLAMP IS 5- FEET.

DIABLO WATER DISTRICT

STANDARD DRAWING  
ANODE AT LEAK REPAIR CLAMP

DESIGNED MA

DRAWN SC

APPROVED JDH

DATE OCTOBER 2022

DWG. NO.

DWD C24

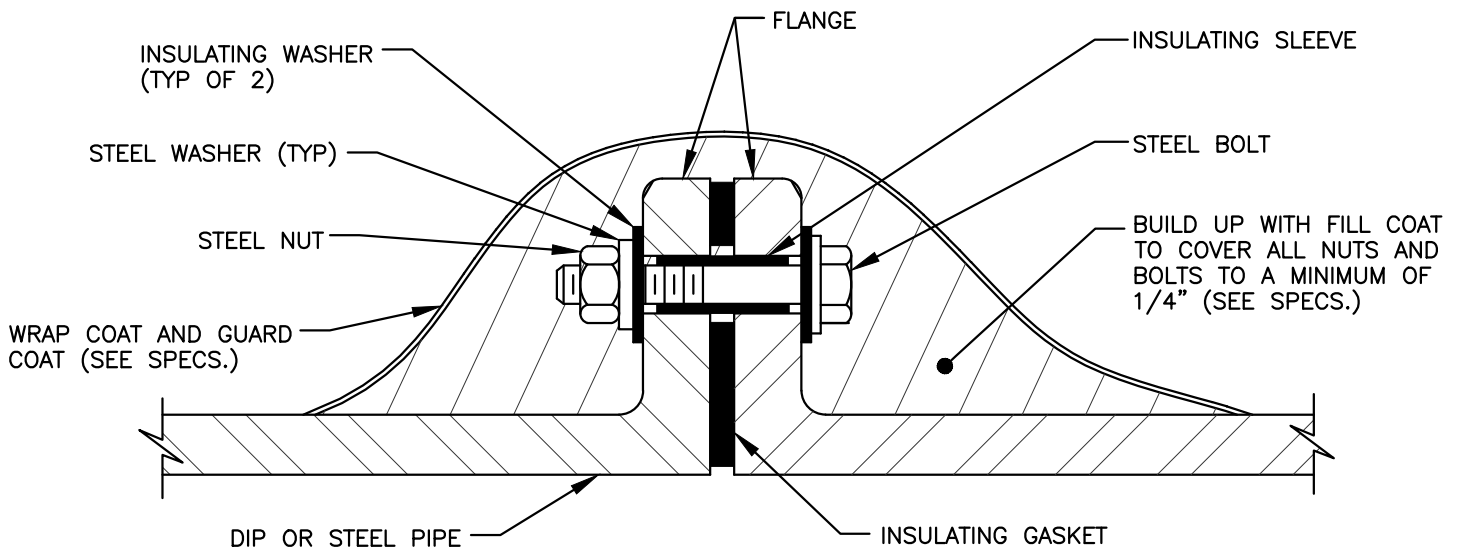

### BELOW GRADE INSULATING JOINT COATING

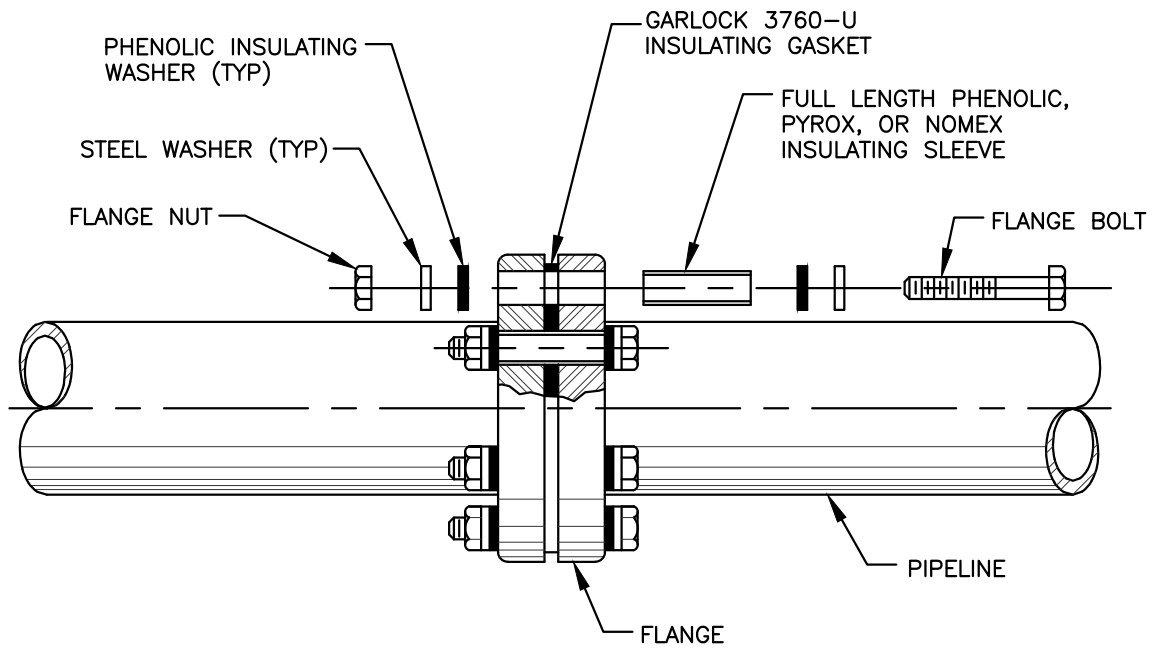

### ABOVE GRADE INSULATING JOINT COATING

NOTE:  
 1. GASKET SHALL BE FOR WATER SERVICE AND BE OF THE SAME PRESSURE RATING AS THE FLANGE.

DIABLO WATER DISTRICT

STANDARD DRAWING  
 INSULATING FLANGE ASSEMBLY

DESIGNED MA      DRAWN SC      APPROVED JDH      DATE OCTOBER 2022      DWG. NO. DWD C25

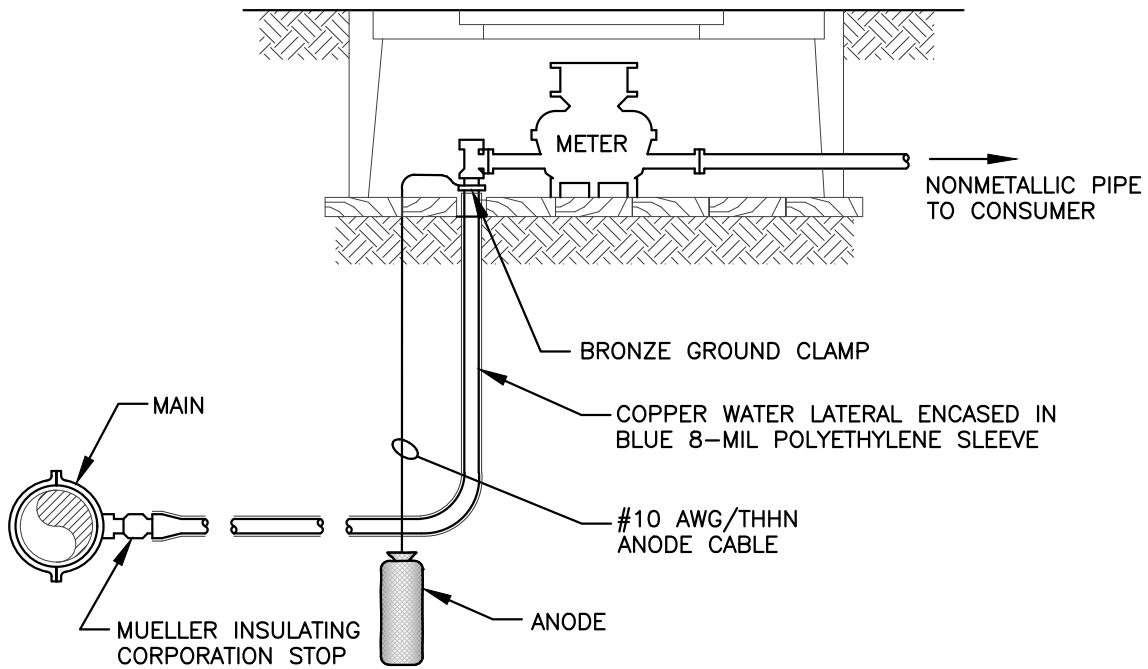

**NOTES:**

1. IF WATER MAIN IS METALLIC, PLACE INSULATING COUPLING BETWEEN COPPER WATER LATERAL AND WATER MAIN.
2. MAINTAIN A MINIMUM CLEARANCE OF 2 FEET BETWEEN THE ANODE AND THE LATERAL.
3. TOP OF ANODE SHALL BE 5 FEET MINIMUM FROM THE GROUND SURFACE.
4. SAME DETAIL APPLIES TO AIR RELEASE VALVES.

**DIABLO WATER DISTRICT**

STANDARD DRAWING  
**COPPER WATER LATERALS ANODE INSTALLATION**

DESIGNED MA

DRAWN SC

APPROVED JDH

DATE OCTOBER 2022

DWG. NO. **DWD C26**



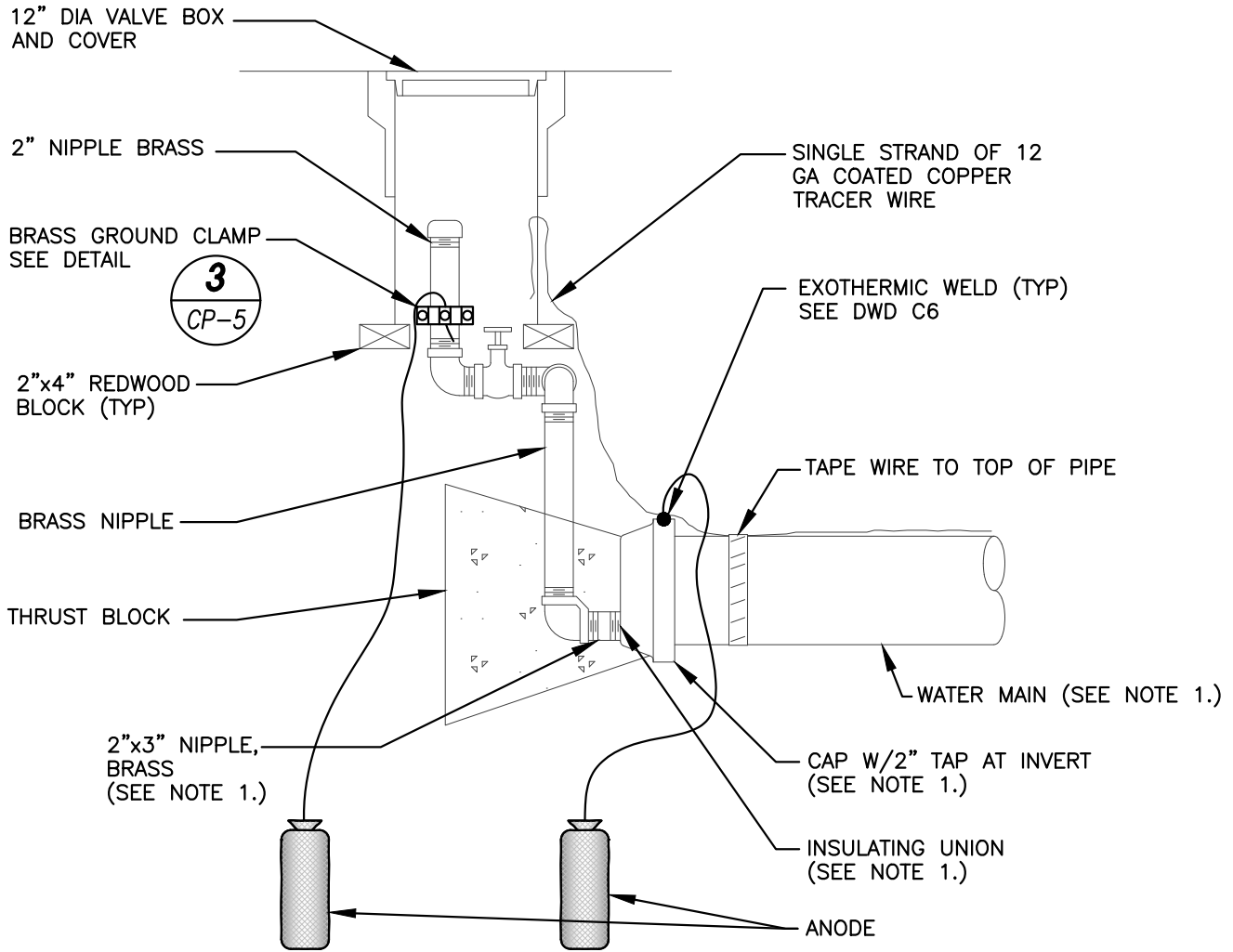

NOTE:

1. WHEN INSTALLING A COPPER BLOW OFF PER DWD STANDARD DRAWING DWD21, PRIOR TO INSTALLING THRUST BLOCK, COAT WITH BITUMASTIC TO COMPLETELY COVER THE DUCTILE IRON CAP. ENCASE ALL BURIED BRASS TUBING IN POLYETHYLENE SLEEVE. INSTALL INSULATING UNION BETWEEN COPPER PIPE AND END CAP, AND COAT THE INSULATING UNION WITH BITUMASTIC.

DIABLO WATER DISTRICT

STANDARD DRAWING  
2" BLOW OFF ANODE INSTALLATION

DESIGNED MA

DRAWN SC

APPROVED JDH

DATE OCTOBER 2022

DWG. NO.

DWD C27

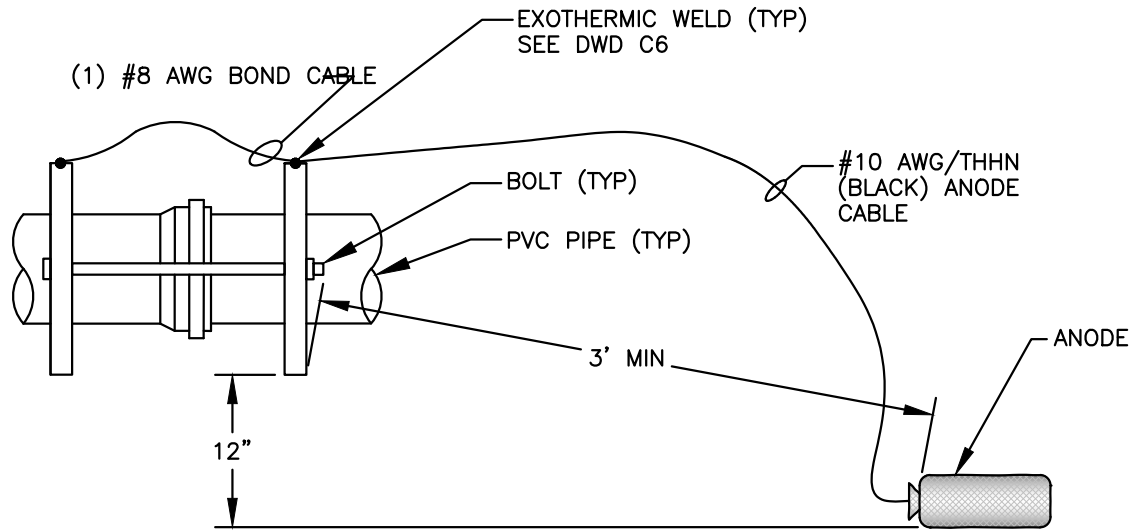

## PROFILE

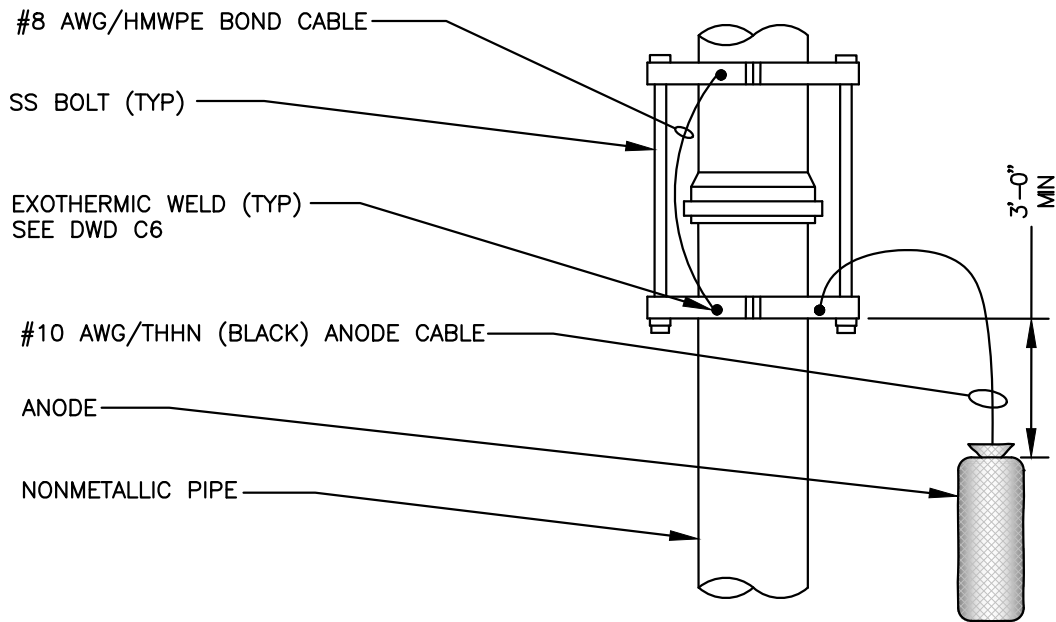

## PLAN

**NOTE:**

1. INSTALL THE ANODE 1'-0" BELOW BOTTOM OF TRENCH IN 1 FOOT OF NATIVE BACKFILL.  
ATTACH ANODE CABLE DIRECTLY TO THRUST RESTRAINT FITTING.

DIABLO WATER DISTRICT

STANDARD DRAWING  
THRUST RESTRAINT HARNESS ANODE INSTALLATION

DESIGNED MA

DRAWN SC

APPROVED JDH

DATE OCTOBER 2022

DWG. NO.

DWD C28

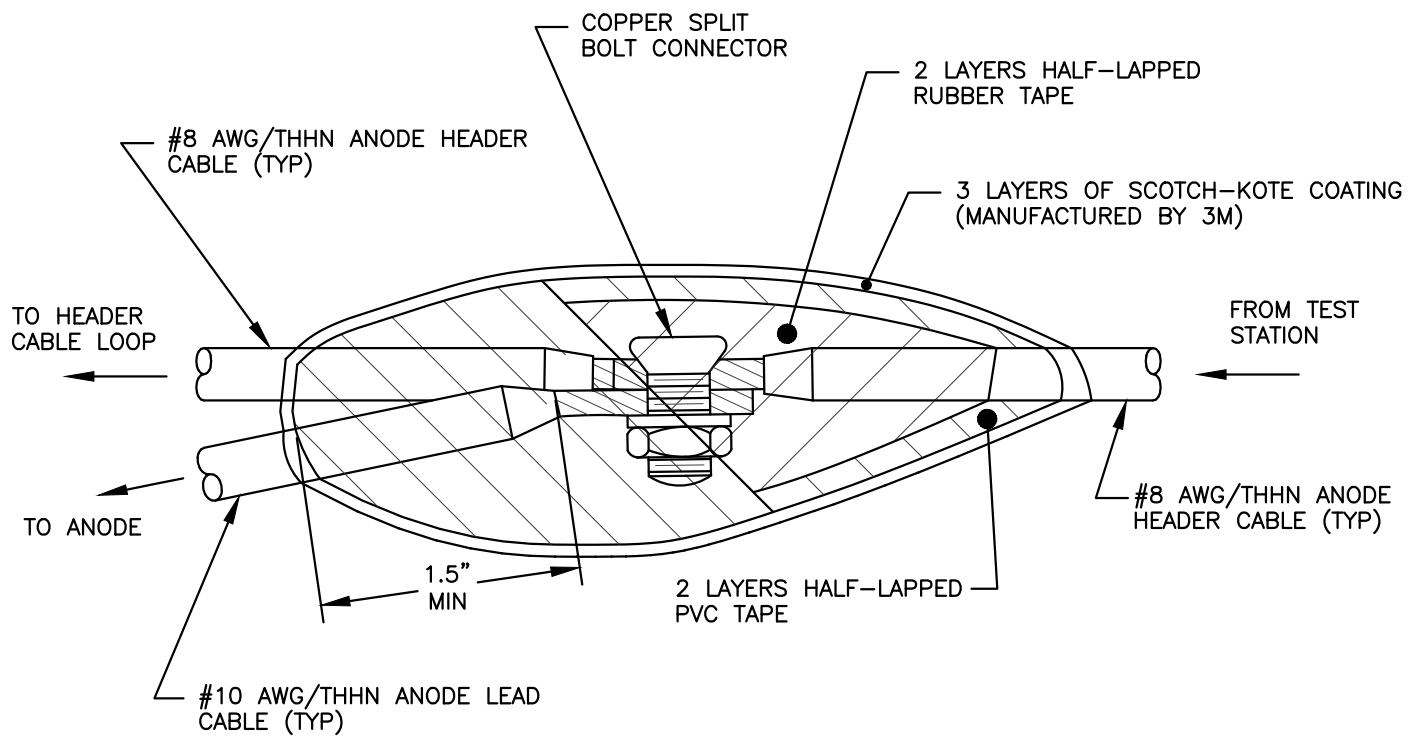

DIABLO WATER DISTRICT

STANDARD DRAWING  
CABLE SPLICE DETAIL

DESIGNED MA

DRAWN SC

APPROVED JDH

DATE OCTOBER 2022

DWG. NO. DWD C29

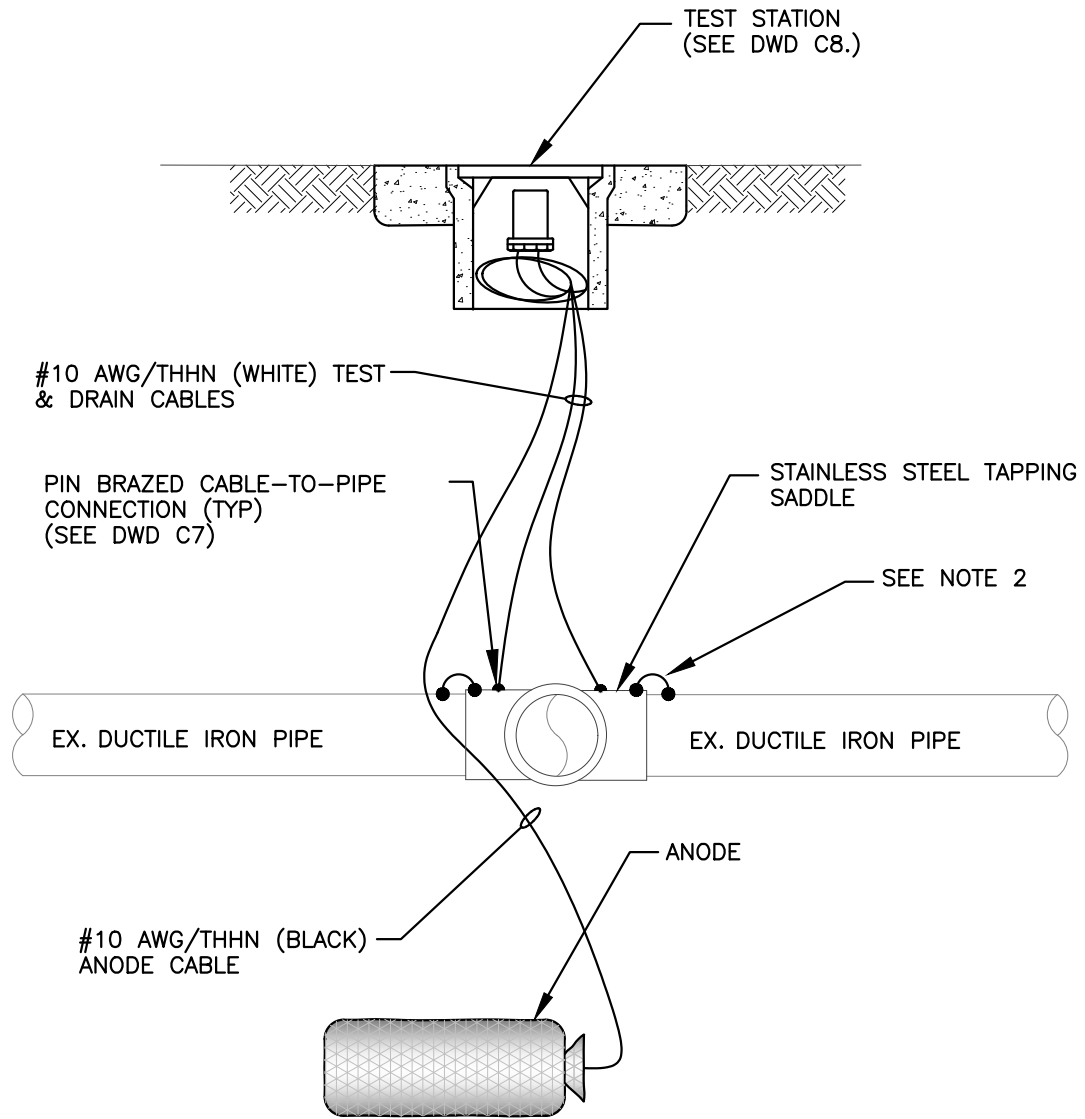

## ELEVATION VIEW

### NOTES:

1. COAT ALL NUTS AND BOLTS WITH BITUMASTIC AND ENCASE ALL DUCTILE IRON PIPE & FITTINGS IN POLYETHYLENE. DO NOT POLYETHYLENE ENCASE THE STAINLESS STEEL SADDLE.
2. NO BONDING REQUIRED FOR PVC PIPE

DIABLO WATER DISTRICT

STANDARD DRAWING  
ANODE AT TAPPING SADDLE

DESIGNED MA

DRAWN SC

APPROVED JDH

DATE OCTOBER 2022

DWG. NO.

DWD C30

## **8. Design Requirements**

**DIABLO WATER DISTRICT  
STANDARD SPECIFICATIONS AND DRAWINGS**

**DESIGN REQUIREMENTS**

- a. Subdivision Water System Design Requirements and Plan Review Checklist
- b. DWD General Water Notes
- c. Cathodic Protection Numbering Format for Subdivision Plans
- d. California Code of Regulations Title 22, Division 4, Chapter 16, Article 4  
Materials and Installation of Water Mains and Appurtenances (includes  
Separation Requirements for Water Mains)
- e. System Pressures and Requirements for Individual Pressure Reducing  
Valves on Customer Services

# Subdivision Water System Design Requirements And Plan Review Checklist

## Design Engineer Responsibilities for Coordination with Other Entities

- Coordinate with joint trench designer.
  - Provide joint trench plans for review along with water system improvements to ensure that there are no conflicts between trees and water facilities.
  - Provide landscaping plans along with water system improvements.
- Coordinate with other utilities regarding water improvements, including but not limited to (as applicable):
  - Contra Costa County Public Works
  - City of Oakley
  - Contra Costa County Fire Protection District
  - East Contra Costa Irrigation District
  - Ironhouse Sanitary District
  - PG & E
  - Reclamation District 799
  - Bethel Island Municipal Improvement District
  - Others as applicable
- Verify consistency of water system information on plans with adjacent subdivisions' plans.
- Provide soils report for review along with improvement plans, if requested.
- Pothole or use GPR to verify existing utilities.
- For developments with more than 50 lots, install ground water monitoring wells in accordance with District Regulation No. 10.

## Water Mains – Sizing and Plan

- Minimum pipe size: 6-inch without fire hydrants and 8-inch with fire hydrants.
- Size water mains to provide adequate fire flows for planned development. Sizes of mains larger than 12-inches must conform to the DWD Facilities Plan.
- Avoid dead end mains if possible.
- Locate water lines so that they are 6-feet North or West of road centerline.
- When a center median exists in roadway, water main shall be centered 6-feet from face of curb.
- Label water line, including size, in a box on the water line.
- Confirm that polyvinyl chloride (PVC) pipe or ductile iron pipe (DIP) will accommodate the bending radius shown on drawings.
- Pipe material for sizes over 12-inches shall be DIP unless otherwise noted.
- New or existing developments with 6-inch water mains shall be replaced with 8-inch water mains to meet the current fire flow standards.
- Design connections to existing water lines to reflect planned future conditions (or as-built conditions, if known).
- Location of stubs to future subdivisions and adjoining properties must be based on approved tentative map (or map under review by City).

## Water Mains – Profile

- Provide required pipe cover:
  - Minimum of 3-feet of cover for all mains and water services; 4-foot minimum cover for major roadways
  - Maximum of 6-feet of pipe cover
  - Provide adequate cover beneath curbs, where water line crosses over storm drain, and other crossing locations. If cover is not adequate at crossing, pipe encasement is required
- Design pipe slopes as follows:
  - Design pipe slopes at minimum of 0.1% (in non-residential areas), and maximum of 10%
  - Avoid flat pipe slopes
  - Use consistent (smooth) pipe slopes (avoid frequent or abrupt changes in slope)

# Subdivision Water System Design Requirements And Plan Review Checklist

- Use pipe elbows or offsets as a last resort, if the bending radius is too tight or if the pipe is too deep (deeper than 6 feet).
- Confirm that PVC or DIP pipes accommodate the bending radius shown on drawings.
- Label pipes with material, size and slope.
- Locate callouts for water line features below the water line (include leader lines, stationing and invert elevation).
- Show size of crossing pipes in correct proportion (for example, an 8-inch pipe should appear smaller than a 24-inch pipe).
- Label elevation grids on both sides of profiles.

## Existing Utilities

- Show existing utilities in plan view.
- Show crossings of existing utilities by waterline in profile.
- Show both existing and new utilities in cross sections.
- Label existing utilities with the type and size.

## Separation of Water, Sewer, and Storm Drain

- Provide minimum horizontal clearance of 10 feet between the outside to outside of pipes for water and sewer.
- Provide minimum 12-inch vertical separation between the outside to outside of pipes for water and sewer at crossings, and in locations where less than 12-foot center to center horizontal separation exists between water and sewer.
- Provide minimum 12-inch vertical separation between water and storm drain if possible. Where unavoidable a minimum of 6-inch vertical separation is required.
- Provide minimum 4-foot horizontal separation clearance from outside to outside of pipes between water and storm drain.
- Cross water and sewer pipes at right angles whenever possible and no less than 45-degrees to and at least 1 foot above the fluid pipeline.
- Comply with California Department of Drinking Water (DDW) Guidance Criteria for the Separation of Water Mains and Non-Potable Pipelines (Revised October 2018 or most recent version). For special cases, the District may approve exceptions as allowed by the DDW criteria.
- Fulfill DDW requirements for pipe materials if separation is not met. Use DIP or Class 200 PVC when minimum separations cannot be maintained.

## Fire Hydrants

- Locate fire hydrants every 500-feet for residential areas, and every 300-feet for commercial areas, or as directed by the local fire protection district.
- Locate a fire hydrant at the end of cul-de-sacs and no more than 250-feet from the end of each cul-de-sac.
- Include a tee, 6-inch valve, and 6-inch lateral for each fire hydrant.
- Do not use reducing elbows.
- Locate fire hydrants so that they are 2-feet clear of the sidewalk.
- Locate fire hydrants so that they are 5-feet clear of the back of curb if there is no sidewalk.
- Provide adequate clearance at fire hydrant laterals that cross other utilities.

## Valves

- Position valves approximately every 500 feet for residential streets.
- Position valves approximately every 700 to 1000-feet for non-residential streets.
- Provide each court with at least one valve located at the tee in the cross street.
- Locate valves so that a pipe break will not affect more than 20 residences (services).
- Use gate valves for pipe sizes up to and including 12-inches, and butterfly valves for pipes larger than 12-inches.
- Where gate valves (GVs) are installed on tees (or crosses) connecting water lines of differing sizes, locate reducers such that the reducer lies between the tee (or cross) and the GV, and the size of the GV matches the adjacent nominal pipe size.



# Subdivision Water System Design Requirements And Plan Review Checklist

- Butterfly valves shall be Mueller Lineseal III 150B, with EPDM seat, provided with holiday-free certification.

## Air-Release Valves

- Design pipes to minimize the need for air release valves, i.e., minimize high points. Use air release valves only when necessary.
- Locate air release valves at high points.
- Locate air release valves anywhere off the street and behind the sidewalk, as long as piping is sloped consistently upward.

## Blowoffs

- In cul-de-sacs and stubs to future development areas, use fire hydrants as an alternative to blowoffs wherever possible.
- If blowoffs are used:
  - Use 2-inch blowoffs for pipe sizes up to and including 12-inches
  - Use 4-inch blowoffs for pipe sizes larger than 12-inches
- Locate blowoffs within the subdivision, otherwise an easement is required.
- If applicable, a blind flange may be used at a tee or cross with a valve that will provide a future connection point. Locate the blind flange immediately adjacent to the valve.

## Services

- Do not directly connect services to mains larger than 12-inches.
  - Separate water and sanitary sewer laterals by 5-feet for their entire lengths.
  - Stagger multiple taps at least 18 inches apart lengthwise and a minimum of 36 inches along the same line/side of the pipe.
  - Use 1-inch service piping.
  - Call out stationing for each service.
  - Do not locate meter box in sidewalk or driveway.
  - Show meter box on typical cross sections.
  - Locate double check valves behind water main (if required).
  - If a fire hydrant is located at the end of a main, locate all services prior to reducers.
- Note: Services to future lots and adjoining properties will require payment of connection fees.

## Cathodic Protection

- Include Cathodic Protection plans at the end of the plan set.
- List Cathodic Protection sheets in the sheet index.

## Details/Cross Sections

- Include a note that thrust blocks shall be installed per DWD Standard Drawings 2 and 3, and provide the specific soil bearing pressure for the subdivision.
- Provide soils report, when available, and/or when requested by the District.
- If pipe encasement is required, include a note referring to DWD Standard Drawing 4 for reinforced pipeline cover section.
- Locate the joint trench underneath the sidewalk, and in front of fire hydrants.
- Position joint trench beneath all water lines.
- For cross sections with a joint trench, include a note stating that the joint trench shall be located under all water lines.

## Right-of-Way and Easements

- Locate water mains, services and meters in the public right-of-way or public utility easement.
- Locate fire hydrants within the right-of-way.
- Locate off-site facilities within the right-of-way.
- In special cases subject to approval of DWD, locate water mains in a minimum 20-foot wide utility easement dedicated to DWD. Locate water mains 5-feet from either edge of an easement.
- Provide additional easements for water meters and other water facilities, if necessary.

# Subdivision Water System Design Requirements And Plan Review Checklist

## General Requirements for Drawings

- Drawing size shall be minimum of 22x34 inches and maximum of 24x36 inches.
- Include sign-off block for Diablo Water District on title sheet.
- Include sign-off block for developer's Geotechnical Engineer and statement of site conditions if subdivision is geotechnically sensitive (as designated by the District).
- List DWD General Water Notes as contained in these "Design Requirements".
- Use a unique symbol for each water system item.
- Show symbols in legend.
- List all abbreviations used for water facilities. Use the standard abbreviations below:
  - ARV Air release valve
  - BF Blind flange
  - BFV Butterfly valve
  - BO Blowoff
  - DIP Ductile iron pipe
  - FH Fire hydrant
  - GV Gate valve
  - PVC Polyvinyl chloride pipe
  - TBO Temporary blowoff
  - W Water main
  - WS Water service
- Label street names consistently.
- Show North arrows consistently in plan and index map.
- Indicate location of fire hydrants, air release valves, blowoffs, and valves on the index map.
- Show lot numbers on index map.
- Show lot numbers on key map.
- Show key map on each plan and profile sheet (for subdivisions with more than three plan & profile sheets). Highlight the street that is the subject of the sheet.
- Quantities Table:
  - Show at a minimum in table format: pipe, valve, fire hydrant, service, and blowoff quantities
  - For re-submittals, update water system quantities

# DIABLO WATER DISTRICT

## General Water Notes

1. Water system shall be installed in accordance with the standards and specifications of the Diablo Water District (District). Contractor to have the October 2022 Specification Book on site at all times. This can be seen online at [www.diablowater.org](http://www.diablowater.org) under documents. Copies of the standards and specifications are available at the District's office at 87 Carol Lane, Oakley, CA, phone: (925) 625-3798, and shall be on site at all times.
2. Anyone who takes water from the District's water system without proper metering shall be subject to the District's tampering charge, fees and costs as per the District's Regulations and may be subject to criminal prosecution pursuant to California Penal Code Section 498 or other applicable statutes.
3. The Developer/Contractor shall submit to the District the soil corrosion analysis and design as required by the District's specifications after rough grading of the site has been completed. No work on the District's water system shall commence until the District has given its approval of the soil analysis and corrosion protection design.
4. All water mains shall be AWWA C900 Class 150 PVC unless otherwise noted on these plans. All plastic PVC water mains and services shall include a 12-gauge, single strand, copper wire taped to the top of the pipe. Top of curb shall be stamped with a "W" to mark the location of the water lateral. Water mains larger than 12-inches shall be DIP unless otherwise noted.
5. Water lines shall have a minimum cover of 3 feet, and not more than 4.5 feet (unless pre-approved by the District) from finish roadway and shall have continuous warning tape installed 18" above all water mains, service lines, hydrant lines and blow-off lines, unless otherwise noted. Warning tape shall be blue, 2" wide, plastic printed continuously with the words "CAUTION BURIED WATER LINE BELOW".
6. Basic separation requirements for water mains and sanitary sewers: New water mains and new supply lines shall not be installed in the same trench as, and shall be installed from outside to outside of pipe at least 10-feet horizontally from and one foot vertically above, any parallel pipeline conveying untreated sewage, disinfected secondary recycled water, and hazardous fluids.
7. Basic separation requirements for water mains and storm drainage and recycled water pipelines: New water mains and new supply lines shall be installed from outside to outside of pipe at least 4-feet horizontally from, and one foot vertically above, any parallel pipeline conveying non-potable water such as, but not limited to, storm drainage and disinfected tertiary recycled water.

8. If crossing a sanitary sewer or storm drain pipeline or recycled water pipeline, a new water main shall be constructed no less than 45-degrees to and at least one foot above that pipeline. No connection joints shall be made in the water main within eight horizontal feet of the pipeline being crossed.
9. Special construction requirements for water mains: where a water main is to be located parallel to or cross a sanitary sewer or storm drain pipeline or recycled water pipeline with less than the required separation, the installation and materials shall conform to the State of California, Division of Drinking Water, California Regulations Related to Drinking Water, and shall be subject to the approval of the Division of Drinking Water.
10. Maintain 5.0' minimum separation between water services and sanitary sewer laterals.
11. Public Fire hydrants shall have 1-4 ½" & 2-2 ½" outlets, and each hydrant shall be isolated from the main line by a 6" gate valve, and shall receive two (2) coats of Rust-oleum V7400 Safety Yellow paint.  
  
Valve can lids for 6" fire hydrant shut-off valve shall be painted with Krylon Interior/Exterior Flat White – Blanco Mate #1502 as per fire department requirements.
12. Use Mueller streamline PVC coated copper for service line and ARV piping.
13. Contractor shall install curb stops and meter boxes acceptable to Diablo Water District at each lot immediately prior to jumper being removed. At the expense of the Developer/Contractor, pad locks will be installed by Diablo Water District at each angle stop.
14. Use 304 stainless steel nuts and bolts for all bolt-ups as well as gate valve bonnets and stuffing box nuts and bolts. Bolts shall be marked 'F-593C' or 'F-593D' only. Heads with two slash marks are not to be used.
15. The Contractor shall maintain water service to all residences at all times during construction.
16. No work shall commence until all submittals have been approved.
17. Thrust blocks (or other pipe joint restraints) shall be provided at all angle points on the water system. Thrust blocks for treated water pipelines (W) shall be per the DWD details.
18. Work hours shall be Monday through Thursday 7:00 a.m. to 4:30 p.m., and Friday 7:00 a.m. to 3:00 p.m., except for District observed holidays. Any requests for working outside these times must be submitted to the District inspector at least 48

- hours in advance. It is recommended that requests for Saturday work be made by the close of business the Wednesday prior. Requests for Saturday work may be approved or denied depending on inspector availability. A request for work during a District holiday shall not be permitted.
19. All joint trench utilities shall cross underneath all water facilities. Developer shall coordinate with joint trench designer to avoid any other conflicts including meter box locations and separation of water and sewer service pipes. Developer to ensure at least 5 inches of separation from water service pipes to the service utilities in the joint trench. If these criteria cannot be met, the Developer/Contractor shall install a red concrete cap over the joint trench facilities.
  20. All Butterfly Valves (BFVs) shall be epoxy lined and coated. Lining shall be certified by the factory to be holiday free.
  21. All hot taps shall be performed by Tap Master, Inc. of Concord, California, phone: 925-439-7975. Tapping sleeve shall be stainless steel type JCM 432, or approved equal.
  22. No trees shall be planted, or light/utility poles installed, within 10' of any water mains, fire services, or fire hydrant laterals. Measurement shall be taken as the clear distance between the root ball and water main or the light/utility pole foundation and water main. Thorny plants or bushes or shrubs shall NOT be planted around fire hydrants, water meters, and back flow preventors that limit access.
  23. All locator wires shall be tested and test results shall be included in the Cathodic Protection Test Report.
  24. All water meters shall be provided with a 520M-FlexNet MTX Unit. Meter boxes for meters less than 1-1/2 inch in size shall have Christy B12P001-F (FlexNet) lids. All meter box lids shall have drilled holes for FlexNet 520M Units.
  25. Water Meters 5/8" in size shall be Sensus 5/8" x 3/4" SRII Low Lead, 1 cubic foot, labeled 5/8" x 3/4". Water Meters 1" in size shall be Sensus 1" SRII Low Lead, 1 cubic foot. Flow meters 1-1/2" through 4" in size shall be Sensus OMNI C2 compound meters (cubic feet).
  26. JDH Corrosion Consultants, Inc., 1100 Willow Pass Court, Concord, CA, 925-927-6630, shall conduct all final cathodic protection test reports at the expense of the Developer/Contractor.
  27. Install a ball shut-off valve and box on customer's side after backflow device for new construction as required by the City of Oakley's specifications.

28. The Developer/Contractor shall provide the Global Positioning System (GPS) coordinates and elevations of all aboveground facilities (including meter boxes, backflows, fire hydrants, CP test stations, G5 and G12 boxes) and underground valves, meters, blowoffs and fittings (including saddles and corporation stops), as determined by the District, in a shapefile data format as defined by ESRI. GPS coordinates of existing water facilities and all other utilities that are exposed during any construction activity shall also be provided. All GPS coordinates shall be to within an accuracy of ten (10) centimeters and shall include Latitude, Longitude and Elevation.
29. The Contractor shall rechlorinate and retest any lines that do not pass the first or subsequent round of bacteriological testing or as directed by Diablo Water District.
30. All materials and products shall be NSF 61 certified that are in contact with and/or potentially in contact with potable water, including surfaces within the air space of the water.
31. If a District water meter is not available for use as a temporary jumper, the Contractor may submit on a meter which must include a current certificate of calibration. Meter must be for potable use only. Contractors using their water meter for the temporary jumper must have yearly calibration tests performed and shall submit the report to the District.
32. Prior to any new connection to existing water main, Contractor shall confirm the outside diameter and material of the existing main.
33. All Ductile Iron Pipe (DIP) water mains shall use Field Lok 350 gaskets and Megalugs shall be installed on all Mechanical Joint (MJ) fittings.
34. Prior to installing sections of pipe, contractor shall ensure the connection elevations are confirmed prior to the installation.

# Cathodic Protection Numbering Format for Subdivision Plans

Example:

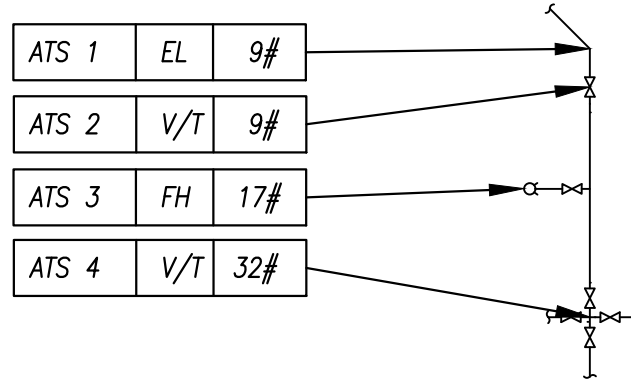

## KEY

ABBREVIATION	DESCRIPTION
ARV	AIR RELEASE VALVE
ATS	ANODE TEST STATION
BO	BLOW OFF
CA	CASING
CATS	CASING TEST STATION
CTS	CORROSION TEST STATION (NO ANODE)
DIP	DUCTILE IRON PIPE LATERAL
EL	ELBOW
FH	FIRE HYDRANT, VALVE & TEE
FP	FOREIGN PIPELINE
FPTS	FOREIGN PIPELINE TEST STATION
FT	FITTING
IJ	INSULATING JOINT
IJTS	INSULATING JOINT TEST STATION
OFST	OFFSET
V/T	CROSS OR TEE W/VALVE(S)
V/TS	TAPPING SADDLE W/VALVE
V&FT	FITTING & VALVE
#	SIZE OF ANODE IN POUNDS

California Code of Regulations Title 22  
 Division 4. Environmental Health  
 Chapter 16. California Waterworks Standards  
 Article 4. Materials and Installation of Water Mains and Appurtenances

*NOTE: This publication is meant to be an aid to the staff of the State Board's Division of Drinking Water and cannot be relied upon by the regulated community as the State of California's representation of the law. The published codes are the only official representation of the law. Refer to the published codes—in this case, 17 CCR and 22 CCR—whenever specific citations are required. Statutes related to the State Board's drinking water-related activities are in the Health & Safety Code, the Water Code, and other codes.*

**§64570. Materials and Installation.**

(a) All newly installed water mains shall comply with the materials and installation standards of the American Water Works Association pursuant to tables 64570-A and 64570-B. The standards are hereby incorporated by reference.

**Table 64570-A  
 Materials Standards for Water Mains**

<u>Type of Material</u>	<u>Diameter of Main</u>	<u>Applicable Standard</u>
PVC	4 in. through 12 in.	C900-97
PVC	14 in. through 48 in.	C905-97
Polyethylene (HDPE)	4 in. through 63 in.	C906-99
Fiberglass	All sizes	C950-01
Ductile Iron	All sizes	C150/A21.50-02
Ductile Iron, Centrifugally cast	All sizes	C151/A21.51-02
Steel	6 inches and larger	C200-97
Copper	All sizes	C800-05
Concrete		
Reinforced steel-cylinder	All sizes	C300-04
Prestressed steel-cylinder	All sizes	C301-99, C304-99
Reinforced noncylinder	All sizes	C302-04
Bar wrapped/steel cylinder	All sizes	C303-02
PVC, Molecularly oriented polyvinyl chloride	All sizes	C909-02

**Table 64570-B  
 Installation Standards for Water Mains**

<u>Type of Installation</u>	<u>Applicable Standard</u>
Steel Pipe-Design and Installation	M-11 (2004)
Ductile-Iron Water Mains and Their Appurtenances	C600-05
Underground Installation of PVC Pressure Pipe and Fittings	C605-05
Concrete Pressure Pipe	M9(1995)

(b) Water mains shall:

- (1) Be installed below the frost line or be otherwise protected to prevent freezing; and
- (2) Be protected against crushing under loads that could pass above the installation.



**§64572. Water Main Separation.**

(a) New water mains and new supply lines shall not be installed in the same trench as, and shall be at least 10 feet horizontally from and one foot vertically above, any parallel pipeline conveying:

- (1) Untreated sewage,
- (2) Primary or secondary treated sewage,
- (3) Disinfected secondary-2.2 recycled water (defined in section 60301.220),
- (4) Disinfected secondary-23 recycled water (defined in section 60301.225), and
- (5) Hazardous fluids such as fuels, industrial wastes, and wastewater sludge.

(b) New water mains and new supply lines shall be installed at least 4 feet horizontally from, and one foot vertically above, any parallel pipeline conveying:

- (1) Disinfected tertiary recycled water (defined in section 60301.230), and
- (2) Storm drainage.

(c) New supply lines conveying raw water to be treated for drinking purposes shall be installed at least 4 feet horizontally from, and one foot vertically below, any water main.

(d) If crossing a pipeline conveying a fluid listed in subsection (a) or (b), a new water main shall be constructed no less than 45-degrees to and at least one foot above that pipeline. No connection joints shall be made in the water main within eight horizontal feet of the fluid pipeline.

(e) The vertical separation specified in subsections (a), (b), and (c) is required only when the horizontal distance between a water main and pipeline is less than ten feet.

(f) New water mains shall not be installed within 100 horizontal feet of the nearest edge of any sanitary landfill, wastewater disposal pond, or hazardous waste disposal site, or within 25 horizontal feet of the nearest edge of any cesspool, septic tank, sewage leach field, seepage pit, underground hazardous material storage tank, or groundwater recharge project site.

(g) The minimum separation distances set forth in this section shall be measured from the nearest outside edge of each pipe barrel.

(h) With State Board approval, newly installed water mains may be exempt from the separation distances in this section, except subsection (f), if the newly installed main is:

- (1) less than 1320 linear feet,
- (2) replacing an existing main, installed in the same location, and has a diameter no greater than six inches more than the diameter of the main it is replacing, and
- (3) installed in a manner that minimizes the potential for contamination, including, but not limited to:
  - (A) sleeving the newly installed main, or
  - (B) utilizing upgraded piping material.

**§64573. Minimum Water Main Size for Community Water Systems.**

Newly installed water mains in a community water system shall have a nominal diameter of at least four inches.

**§64575. Flushing.**

(a) A flushing valve or blowoff shall be provided at the end of each newly installed dead-end water main. Fire hydrants meeting the criteria of this section may be considered flushing valves.

(b) Flushing valves and blowoffs shall not discharge to a sanitary sewer without an air gap separation between the sewer and the valve or blowoff.

(c) The flushing velocity in the main shall not be less than 2.5 ft/s unless it is determined that conditions do not permit the required flow to be discharged to waste.

(d) Newly installed flushing valves and blowoffs shall be designed to maintain the minimum continuous flushing flows as indicated below to produce a minimum velocity of 2.5ft/s in commonly used sizes of pipe.

**Table 64575-A. Minimum Flushing Flows for Different Size Water Mains.**

<i>Nominal Main Size Diameter (inches)</i>	<i>Minimum Flushing Flow (gallons per minute)</i>
2	25
3	50
4	100
6	225
8	400
10	600
12	900
14	1200
16	1600

**§64576. Air-Release, Air Vacuum, and Combination Valves.**

Each new air-release, air vacuum, or combination valve, and any such valve installed to replace an existing valve shall be:

(a) Installed such that its vent opening is above grade, above the calculated 100-year flood water level, and, if recorded data are available, above the highest recorded water level;

(b) Readily accessible for inspection, maintenance and replacement;

(c) Constructed and designed to prevent exposure to rainwater or runoff, vandalism, and birds, insects, rodents, or other animals;

(d) Fitted with a downward-facing screened vent or a domed and screened cap; and

(e) Installed pursuant to American Water Works Association Standard C512-04 and Manual M51 (2001), which are hereby incorporated by reference.

**§64577. Isolation Valves.**

As a minimum, isolation valves shall be installed on all new water mains within the distribution system as follows:

- (a) No farther than 1,320 linear feet apart on all mains having a diameter of 12 inches or less.
- (b) At each tee or crossing connection between mains that have a diameter of 12 inches or less, within 100 feet of the tee or crossing connection with the primary main.
- (c) Between the water main and each fire hydrant served by the main.

**§64578. Water Main Valve Construction.**

Newly installed valves constructed on water mains shall comply with the following:

- (a) A valve box shall be installed over each buried valve stem to aid in locating and operating the valve.
- (b) For valves buried in trenches greater than five feet below the finished grade, either a valve stem riser to permit the use of a normal key or a notation on valve records indicating that a long key will be required shall be provided.

## **SYSTEM PRESSURES AND REQUIREMENTS FOR INDIVIDUAL PRESSURE REDUCING VALVES ON CUSTOMER SERVICES**

### 1.01 SYSTEM PRESSURES

Water pressures throughout Diablo Water district's system range from 40 psi to over 100 psi, and may reach up to 120 psi in some locations. Higher pressures are generally associated with lower ground elevations.

### 1.02 RESPONSIBILILTY FOR PROTECTION AGAINST EXCESSIVE PRESSURES

The District has no pressure regulating devices in its system. Protection of individual domestic, commercial, and industrial units against excessive water pressure is the responsibility of the Applicant. The Uniform Plumbing Code requires pressure reducing valves on all new services where peak pressures exceed 80 psi.

### 1.03 DISTRICT DESIGNATION OF LOCATIONS FOR INDIVIDUAL PRV

Individual pressure reducing valves shall be required on all customer services at locations designated by the District, which are typically areas with ground elevations less than 15 feet above mean sea level.

### 1.04 REQUIREMENTS FOR LOCATIONS DESIGNATED BY DISTRICT

At low elevation locations as designated by the District, the applicant shall install a pressure reducing valve, approved by the District, at the water service entrance to every structure or facility that will receive water service from the District in order to minimize the effects of higher than normal pressure at the location of the development.

Applicant shall also be required to place a covenant which runs with the land in every deed evidencing the sale of each house in a development which places the owners of each house on notice of the responsibility to maintain the pressure reducing valves and that the District is not liable for any damage which may result due to water pressure. The form of the covenant shall be as designated by the District in its agreement with the Applicant. The covenant shall be in place prior to the commencement of water service.

## **9. Construction Activities**

**DIABLO WATER DISTRICT  
STANDARD SPECIFICATIONS AND DRAWINGS**

**CONSTRUCTION ACTIVITIES**

- I. Construction Sequence and Requirements
- II. Construction Submittal Checklist



## DIABLO WATER DISTRICT

### Sequence and Specifications to Work on DWD Facilities Including but Not Limited to the Following:

1. Before the start of a Job or Subdivision:
  - a) Agreement in place.
  - b) Insurance in place.
  - c) Contractor to be approved by DWD.
  - d) 4 sets fully signed plans and PDF copy.
  - e) Phone Numbers – day time & emergency (after hours):
    - 1) Foreman and/or Superintendent
    - 2) Safety Officer
    - 3) Any other needed to complete job.
  - f) Safety officer is on location at all times.
  - g) Cathodic soils test results.
  - h) Cathodic plans and design – if needed.
  - i) All submittals complete and approved
  - j) All materials checked on location by the contractor.
    - 1) After materials have been received and checked by the contractor, the contractor shall notify DWD representative that the proper materials have been delivered. DWD representative will inspect the same at earliest convenience.
  - k) Specification book, plans, and approved submittals shall be on location at all times.
  - l) Potholing completed in full
  - m) All services hand tapped (no power drills).
  - n) Joint Trench under or re-routed around water utilities, inform Inspector of any problems.

- o) Diablo Water District must receive a written request to work outside of Diablo Water District's regular work hours Monday through Thursday 7:00 a.m. to 4:30 p.m., and Friday 7:00 a.m. to 3:00 p.m., except for District observed holidays. Requests will be received no later than Wednesday @ 4:30 p.m. for work on Saturday – no holiday work or 3 day weekend work is allowed. Please e-mail your request to Wayne Weaver ([wweaver@diablowater.org](mailto:wweaver@diablowater.org)) and [developer@diablowater.org](mailto:developer@diablowater.org)). Tie-ins cannot occur at night without proper notification. District may choose to make tie-ins after hours so it does not interfere with businesses, etc.
2. Testing sequence after jumper is installed and tested.
    - a) 1<sup>st</sup> pressure test – before rock and after sufficient backfill (as determined by DWD employee).
    - b) 2<sup>nd</sup> pressure test – after rock (100%), curb & gutter & sidewalks poured, services cut down, boxes installed (on 2 x 4 rough redwood).
    - c) Final lift of paving shall occur after 2<sup>nd</sup> pressure test.
    - d) Bacteria testing (no coliforms and < 50 background). See Section 02675 of DWD Standard Specifications.
      - 1) Cl2 (50 ppm) in system min. of 24 hours – (best 48+ hours).
      - 2) Flush – (min. 24 hours set time after flush).
      - 3) Bacteria samples taken (approx. 24 hours before results are available).
      - 4) Bacteria sample testing shall include, but not limited to, total coliform, non-sheen bacteria, and heterotrophic plate count.
      - 5) Re-chlorinate and retest as needed till testing passes.
  3. After bacteria test passes:
    - a) Install meter(s) before any tie-ins are made or be in the process of installation.
    - b) Jumper and/or plates to be pulled within 14 days or new bacteria samples to be taken.
    - c) House services can now be connected.
    - d) Tamper tags to be installed by DWD.
    - e) Tie-in bacteria test will be taken.



4. Before job acceptance:
  - a) Job must be completed.
  - b) Submit GIS location records of all new water line features, including cathodic protection features, per DWD General Requirements Section 1.06.
  - c) As-built plan Mylars to DWD (suggest blue line as-builts first).
  - d) Cathodic protection (if needed):
    - 1) Tested and certified by JDH Corrosion Consultants, Inc. at the expense of the Developer/Contractor.
    - 2) As-built Mylars (suggest blue lines first).
5. DWD will assess a time frame for all punch list items to be completed. If not completed at designated time, the District will do so or have done by others after contacting the bonding company.

DWD will increase the deposit to cover the estimated punch list items. The deposit shall be refunded if the punch list is completed to the District's satisfaction within the stated time frame.



Subdivision or Project: \_\_\_\_\_

PLEASE SKIP NUMBERS THAT DO NOT APPLY

\*\* PLEASE VISIT [www.diablowater.org](http://www.diablowater.org) \*\*  
FOR THE LATEST UPDATES

Submittal Number	Specification Reference	Drawing Reference	Submittal Description	Date Received From	Returned Response	No Exceptions Taken	Make Corrections Noted- <i>No need to re-submit</i>	Amend & Resubmit	Rejected	Submittal Required but not Received
				Contractor	DWD					
1-A	02231-2.01.A	DWD 5	Bore and Jack Casing							
2-A	02231-2.01.D	DWD 5	Bore and Jack Insulators: Calpico Model W / Williamson M-2, stainless steel bands and hardware							
3-A	02512	DWD 6	Double Offset: Minimum I.D. shall be nominal Include Size							
4-A	02512	DWD 7	Single Offset: Minimum I.D. shall be nominal Include Size							
5-A	02610-2.01.A	--	Ductile Iron Pipe: U.S. Pipe / American Cast Iron / Clow Pacific States or Approved Equal							
6-A	02610-2.01.B	--	Flanged Coupling Adapters: Smith-Blair Type 913 with EPDM gaskets or Approved Equal							
7-A	02610-2.01.B	--	Sleeve/Mechanical Couplings for Ductile Iron Pipe: Dresser 38 or 138, EPDM gaskets							
8-A	02610-2.01.B&C 02620-2.02.F	--	Push on Ductile Iron Pipe Fittings: Sigma / Tyler / Star							
9-A	02610-2.01.B&C 02620-2.02.F	--	MJ Ductile Iron Pipe Fittings: Star / Sigma / Tyler							
10-A	02610-2.01.B&C 02620-2.02.F	--	Flanged Ductile Iron Pipe Fittings: Sigma / Tyler / Star							
11-A	02610-2.01.B.1	--	Locking Joints for Ductile Iron Pipe: Field Lok 350 by U.S. Pipe Fitting							
12-A	02620-2.02.G&I	--	C900 PVC Pipe: Vinyl Tech, Royal Group, or Northern Pipe Products C900 Fusible PVC Pipe: Aegion							

Subdivision or Project: \_\_\_\_\_

Submittal Number	Specification Reference	Drawing Reference	Submittal Description	Date Received From	Returned Response	No Exceptions Taken	Make Corrections Noted- <i>No need to re-submit</i>	Amend & Resubmit	Rejected	Submittal Required but not Received
				Contractor	DWD					
13-A	02620-2.03.A	DWD 1	No. 12 Copper Detection Wire: Solid with blue insulation							
14-A	02620-2.03.B	DWD 1	Plastic Warning Tape: Blue, minimum 6-inch							
15-A	02620-2.02.D.3	--	Sleeve/Mechanical Couplings for PVC Pipe: Hymax Coupling, Dresser 253, long style, EPDM gaskets							
16-A	02675	--	Disinfection and Dechlorination Test Plan							
17-A	02830-Part 2	DWD 14	Fence Materials							
18-A	15100-2.03.D	DWD 15 DWD 17	Gate Valves: Mueller with stainless steel trim and hardware							
19-A	15100-2.04. H & J	DWD 19	Butterfly Valves: Mueller Lineseal III Class 150B or Mueller Lineseal XP Class 250B, no equal certified with serial number, Interior with EPDM rubber seat							
20-A	15100-2.05.C	--	Ball Valves: Watts Series B-6000/Mueller B20200 Must be Lead Free							
21-A	15100-2.06.A	--	Insulating Fittings: Watts Regulator Co.							
22.1-A	15100-2.07.A	DWD 15	Fire Hydrants: Clow 960							
22.2-A	15100-2.07.D	DWD 15	Fire Hydrants: Two coats of Rust-oleum V7400 Safety Yellow							
22.2-A	15100-2.07.E	DWD 15	Fire Hydrants: NSF 61 Approved Lubricant							
23-A	15100-2.07.B	DWD 15	Hydrant Check Valve and Break Off Spool: Clow LB400							
24-A	15100-2.07.C	DWD 15	Ductile Iron Hydrant Bury: Sigma or South Bay							

Subdivision or Project: \_\_\_\_\_

Submittal Number	Specification Reference	Drawing Reference	Submittal Description	Date Received From	Returned Response	No Exceptions Taken	Make Corrections Noted- <i>No need to re-submit</i>	Amend & Resubmit	Rejected	Submittal Required but not Received
				Contractor	DWD					
25-A	15100-2.08.B	DWD 23 or DWD 20	ARV: Crispin UL10.1 / Apco 143C							
26-A	15100-2.08.B	DWD 20	ARV Screen: Christy 1" FPT #10 or DWD approved equal							
27-A	15100-2.08.B	DWD 23	Angle Valve for ARV: Mueller B-24258							
28-A	15100-2.08.B	DWD 23 or DWD 20	ARV Concrete Box and Lid: Christy N36 with extension							
29-A	15100-2.09	DWD 21	Blowoff Piping and Fittings: Brass for 2"							
30-A	15100-2.09.D	DWD 21	Angle Valve for Blowoff: Mueller B-24286 for 2"							
31-A	15100-2.10.A	--	Dielectric Unions and Flange Unions: EpcO Inc.							
32-A	15100-2.10.D	--	Flanged Coupling Adapters: Dresser Style 127 or 128 / Hymax / Baker, stainless steel hardware							
33-A	15100-2.10.E.4	--	MJ Joint Restraint: EBAA Iron Megalug							
34-A	15100-2.10.E.2	--	Pipe Restraining Clamp Assemblies: Stellar Corporation							
35-A	15100-2.10.F or 02610-2.01.B.2	--	Flange Gaskets: Garlock 3760-U							
36-A	15100-2.10.F	--	Stainless Steel Bolts and Nuts F-593C or D shall be stamped on head of bolt							
37-A	15100-2.10.F	--	Protective Tape Wrap: 10 Mil Tape							
38-A	15100-2.10.G	DWD 17	G5 Valve Boxes: Christy Include "Water" on lid							

Subdivision or Project: \_\_\_\_\_

Submittal Number	Specification Reference	Drawing Reference	Submittal Description	Date Received From	Returned Response	No Exceptions Taken	Make Corrections Noted- <i>No need to re-submit</i>	Amend & Resubmit	Rejected	Submittal Required but not Received
				Contractor	DWD					
39-A	15100-2.10.G	DWD 17	G12 Valve Boxes: Christy Include "CP Test" or "Water" on lid							
40-A	15100-2.10.H	--	Tapping Sleeves: Up to 18" - JCM 432, all stainless materials and hardware Over 18" - Contact DWD							
41-A	15400-2.01.A&B	DWD 8	Up to 1" Copper Service Piping: Type K Soft, Polycoated Mueller Streamline Over 1" Type K Soft Mueller Streamline							
42-A	--	--	Above 1" Copper Service Line Poly Wrap: Blue							
43-A	15400-2.01.C	DWD 8	Service Saddles for PVC Pipe:  Mueller, cc thread, bronze, wide band							
44-A	15400-2.01.C	DWD 8	Service Saddles for Ductile Iron Pipe: Mueller, cc thread, full circle stainless steel							
45.1-A	15400-2.02.A	DWD 8	5/8" - 1" Flow Meter: Sensus SR11 Low Lead flow meter (CF)							
45.2-A	15400-2.02.B	DWD 8	1-1/2" - 2" Flow Meter: Sensus Omni C2 flow meter (CF) with							
45.3-A	15400-2.02.C	DWD 8	3" & 4" Flow Meter Sensus Omni C2 flow meter (CF)							
46-A	15400-2.02.A 15400-2.02.B 15400-2.02.C	DWD 8	520M-FlexNet MTX Unit							
47-A	--	DWD 8	Straight Meter Coupling: Mueller H-10892 Meter coupling: H1089ON							
48-A	15400-2.03	DWD 8 DWD 9  DWD 10	Meter Boxes: Christy B-12, B-16, B-30, B-40, or B-44 Lid for B-12 Box: B12P Lid for B-16 Box: B16P Lid must read "WATER" Lid must incorporate FlexNet 520M							

Subdivision or Project: \_\_\_\_\_

Submittal Number	Specification Reference	Drawing Reference	Submittal Description	Date Received From	Returned Response	No Exceptions Taken	Make Corrections Noted- <i>No need to re-submit</i>	Amend & Resubmit	Rejected	Submittal Required but not Received
				Contractor	DWD					
49-A	15400-2.03.B	DWD 8 DWD 20	1" Angle Meter Stops: Mueller B-24258							
50-A	15400-2.03.B	DWD 8	1-1/2" - 2" Angle Meter Stops: Mueller B-24276							
51-A	15400-2.04 or 16640-1.04.D	DWD 8 DWD C24	1" - 2" Corporation Stops: Mueller B-25008 Metalic water main-Muller insulated corp P# N35008							
52-A	15400-2.05.B	DWD 10	3/4" - 2" Double Check Valve: Febco LF850U (Must be Lead Free) 1/4" MIP 1/4" Flare Adapter Test Fitting							
53-A	15400-2.05.C	DWD 11	3/4" - 2" Reduced Pressure Backflow Preventer: Febco LF825YA RP with ball valves 1/4" MIP 1/4" Flare Adapter Test Fitting (Must be Lead Free)							
54-A	15400-2.05.C	--	Backflow Fittings: Must be Lead Free Brass							
55-A	15400-2.05.C	DWD 11	Backflow Cage & Freeze Cover sized for device & cage BPD I Guardshack two-piece enclosure hinged, similar to Cage #GSM1 modified per DWD drawing on file with BPD I, powder coated Stainless Steel, Forest Green							
56-A	15400-2.05.C	DWD 12	2-1/2" - 10" Reduced Pressure Backflow Preventer: Febco LF880V N-shape w/Setter							
57-A	15400-2.05.D	DWD 13	2 1/2" - 10" Double Check Detector Valve: Febco LF876V N-shape w/Setter							
58-A	16640-1.03 to 1.05	--	Corrosion Control Design After Rough Grading							
59-A	16640-Part 2	DWD C1- DWD C29	Corrosion Control Products							
60-A	--	--	Bitumastic							